



G W Y D I R
SHIRE COUNCIL

MINUTES OF ORDINARY MEETING

Held on Thursday 30 May 2024

Commencing at 2:00 pm

in the Roxy Conference Room

Present

Councillors:	Cr John Coulton (Mayor), Cr Catherine Egan (Deputy Mayor), Cr Jim Moore, Cr Geoff Smith, Cr David Coulton, Cr Tiffany Galvin, Cr Chris Matthews and Cr Lyndon Mulligan
Staff:	Max Eastcott (General Manager), Leeah Daley (Deputy General Manager), Helen Thomas (Manager Finance), Alex Eddy (Director Engineering Services), Justin Hellmuth (Business Improvement and IT Coordinator) and Bronwyn Wilson (Executive Assistant)
Public:	
Visitors:	

DISCLAIMER

No responsibility whatsoever is implied or accepted by the Gwydir Shire Council for any act, omission or statement or intimation occurring during Council or Committee meetings.

The Council disclaims any liability for any loss whatsoever and howsoever caused arising out of reliance by any person or legal entity on any such act, omission or statement or intimation occurring during Council or Committee meetings.

Any person or legal entity who acts or fails to act in reliance upon any statement, act or omission made in a Council or Committee meeting does so at that person's or legal entity's own risk.

In particular and without derogating in any way from the broad disclaimer above, in any discussion regarding any planning application or application for a licence, any statement or intimation of approval made by any member or officer of the Council during the course of any meeting is not intended to be and is not taken as notice of approval from the Council.

Gwydir Shire Council wishes to advise that any plans or documents contained within this Agenda may be subject to copyright law provisions and that the express permission of the copyright owner(s) should be sought prior to their reproduction.

Members of the public should note that no action should be taken on any item discussed at a Council or Committee meeting prior to written advice on the resolution of Council being received.

Agendas and minutes are available on the Council's website:

<https://www.gwydir.nsw.gov.au/Home>

ACKNOWLEDGMENT OF COUNTRY

The Gwydir Shire Council acknowledges that this meeting is being held on Aboriginal land and recognise the strength, resilience and capacity of Gomeri people in this land.

Content	Page No.
1 Official Opening and Welcome - Mayor	4
2 Apologies	4
3 Confirmation of the Minutes	4
4 Presentation	4
5 Call for the Declarations of Interests, Gifts Received and Conflicts of Interest	4
6 Additional/Late Items	4
7 Mayoral Minute	5
8 Notice of Motion	5
9 Officers' Reports	7
9.1 May 2024 Committee Recommendations.....	7
9.2 Executive Services	10
9.3 DA 29/2023 / PAN-341806	46
9.4 April 2024 Investment and Rates Collection Report	108
9.5 Asset Disposal Policy	112
9.6 Draft Gifts and Benefits Policy	123
9.7 Gwydir Shire Legislative Compliance Policy.....	127
9.8 Audit, Risk and Improvement Committee (ARIC) Minutes.....	136
9.9 Quarterly Financial Review - March 2024.....	228
10 Councillors' Reports	239
11 Committee of the Whole - Confidential Items	239
11.1 Adoption of the Recommendations of the Confidential Session.....	239
12 Closure	241

1 OFFICIAL OPENING AND WELCOME - MAYOR

The Mayor welcomed all present to the meeting.

2 APOLOGIES

An apology was received from Cr Dixon OAM.

COUNCIL RESOLUTION:

THAT the apology received from Cr Dixon OAM is accepted.

Moved Cr Egan, Seconded Cr Matthews

CARRIED

For: Cr J Coulton, Cr Egan, Cr D Coulton, Cr Galvin, Cr Matthews, Cr Moore, Cr Mulligan and Cr Smith

Against: Nil

3 CONFIRMATION OF THE MINUTES

COUNCIL RESOLUTION:

THAT the Minutes of the Ordinary and Confidential Meetings held on Thursday 18 April 2024 as circulated be taken as read and CONFIRMED.

(Moved Cr D Coulton, Seconded Cr Smith)

CARRIED

For: Cr J Coulton, Cr Egan, Cr D Coulton, Cr Galvin, Cr Matthews, Cr Moore, Cr Mulligan and Cr Smith

Against: Nil

4 PRESENTATION

5 CALL FOR THE DECLARATIONS OF INTERESTS, GIFTS RECEIVED AND CONFLICTS OF INTEREST

Cr Matthews declared a pecuniary interest in the Notice of Motion as a part owner of the land which houses the Bingara Op-Shop.

Cr Moore declared a significant non-pecuniary interest in Item 7.1 of the Confidential Agenda, Fuel Report, as the employee of a principal involved in the tender.

6 ADDITIONAL/LATE ITEMS

COUNCIL RESOLUTION:

THAT the following Items, namely:

- **Item 7.4 Confidential Agenda Property Matters**
- **Item 7.5 Confidential Agenda Vacuum Excavator Purchase**
- **Confidential verbal report on the Draft Audit Report concerning Council's road assets.**
-
- **are accepted as late Items to this Agenda for discussion.**

(Moved Cr Matthews, Seconded Cr Egan)

CARRIED

For: Cr J Coulton, Cr Egan, Cr D Coulton, Cr Galvin, Cr Matthews, Cr Moore, Cr Mulligan and Cr Smith

Against: Nil

7 MAYORAL MINUTE

Nil

8 NOTICE OF MOTION**Item 8.1 Notice of Motion**

Cr Galvin to move:

THAT the Council allocate the building currently occupied by the Town Utilities Staff, within the Bingara Depot and at the back of the Bingara Library Building, to the Council's Section 355 Bingara Community Op-Shop Committee once the new Administrative Office has been built and the Depot has been decommissioned.

Notes to support the Notice of Motion:

The Bingara Op-Shop has been operating for 3 years and has, during this period, returned over \$100,000 to various community groups and institutions in donations.

The venture has been an outstanding success and has become an important meeting place and resource for many of Bingara's residents. It requires some additional space to allow it to continue effectively and efficiently to function. The adoption of this motion will allow the Committee to forward plan its growth into the future.

The siting of the building will mean that its possible transfer will not diminish the redevelopment of the remaining Depot Land for suitable housing options.

Please contact the Op-Shop if you would like to inspect the site.



NOTICE OF MOTION RECOMMENDATION

THAT the Council allocate the building currently occupied by the Town Utilities Staff, within the Bingara Depot and at the back of the Bingara Library Building, to the Council's Section 355 Bingara Community Op-Shop Committee once the new Administrative Office has been built and the Depot has been decommissioned.

COUNCIL RESOLUTION:

THAT the Council allocate the building currently occupied by the Town Utilities Staff, within the Bingara Depot and at the back of the Bingara Library Building, to the Council's Section 355 Bingara Community Op-Shop Committee once the new Administrative Office has been built and the Depot has been decommissioned.

FURTHER that this arrangement cease if the Bingara Op Shop closes at some point in the future.

(Moved Cr Galvin, Seconded Cr Egan)

CARRIED

For: Cr J Coulton, Cr Egan, Cr D Coulton, Cr Galvin, Cr Moore, Cr Mulligan and Cr Smith

Against: Nil

Cr Matthews, having declared his interest, left the meeting during discussion of this item.

9 OFFICERS' REPORTS

9.1 May 2024 Committee Recommendations

File Reference: NA

Delivery Program

Goal: 5. Organisational management

Outcome: 5.1 Corporate management

Strategy: 5.1.3 Administrative and support functions

Author: Executive Assistant

STAFF DISCLOSURE OF INTEREST Nil

IN BRIEF/SUMMARY RECOMMENDATION

This report recommends the adoption of the recommendations from the Public Infrastructure and Community Services and Planning Committee Meetings held on 16th May 2024.

TABLED ITEMS Nil

COMMITTEE RECOMMENDATIONS:

Public Infrastructure Committee Meeting Technical Services

THAT the Monthly Technical Services Report for April 2024 be received.

Further that the Council express its complete dissatisfaction with the acquittal process being used in the reimbursement of flood claims.

Further that the Council support the Bingara Lions Clubs' endeavours to have a public phone located at the skate park in Bingara.

Community Services and Planning Committee

THAT the report be received.

FURTHER that the Council write to Inverell Shire Council requesting some support towards the operations of both the Tharawonga Preschool at Yetman and CHSP programs operating within Inverell Shire.

FURTHER that this Shire place an appropriate large sign at the Delungra CHSP noting Gwydir Shire's sponsorship of the activity.

Draft Long Term Financial Plan

THAT the 2024/2025 LTFP be placed on public display for the 28 days' period to allow for community comments and submissions.

Confidential Community Services and Planning Committee

THAT the report be received.

Property Matter

THAT the Council revise its offer to \$225,000.

ATTACHMENTS

Nil

COUNCIL RESOLUTION:

Public Infrastructure Committee Meeting Technical Services

THAT the Monthly Technical Services Report for April 2024 be received.

Further that the Council express its complete dissatisfaction with the acquittal process being used in the reimbursement of flood claims.

Further that the Council support the Bingara Lions Clubs' endeavours to have a public phone located at the skate park in Bingara.

Community Services and Planning Committee

THAT the report be received.

FURTHER that the Council write to Inverell Shire Council requesting some support towards the operations of both the Tharawonga Preschool at Yetman and CHSP programs operating within Inverell Shire.

FURTHER that this Shire place an appropriate large sign at the Delungra CHSP noting Gwydir Shire's sponsorship of the activity.

Draft Long Term Financial Plan

THAT the 2024/2025 LTFP be placed on public display for the 28 days' period to allow for community comments and submissions.

Confidential Community Services and Planning Committee

THAT the report be received.

Property Matter

THAT the Council revise its offer to \$225,000.

(Moved Cr Egan, Seconded Cr Galvin)

CARRIED

For: Cr J Coulton, Cr Egan, Cr D Coulton, Cr Galvin, Cr Matthews, Cr Moore, Cr Mulligan and Cr Smith

Against: Nil

9.2 Executive Services

File Reference: NA

Delivery Program

Goal: 5. Organisational management

Outcome: 5.1 Corporate management

Strategy: 5.1.3 Administrative and support functions

Author: Max Eastcott, General Manager

STAFF DISCLOSURE OF INTEREST Nil

IN BRIEF/SUMMARY RECOMMENDATION

This report is for reception.

TABLED ITEMS Nil

BACKGROUND

PLANNING

Planning – April 2024

The following Development (D/A) and Development Modification (s96) applications were approved during the month of April 2024.

No.	Property Description	Development/Work	\$	DA	s4.55
9/2024	D J M Butler & C L Barwick Lot G DP 410808 14 Crane Street Warialda	Construction of a 3-bay garage	\$19,500	✓	
10/2024	A G & K M Matthews Lot 11 DP 4147 21 Bingara Street Warialda Rail	Install an inground Swimming Pool and Child Safety Barrier	\$82,440	✓	
11/2024	P J & L K Hickey Lot 10 Section 3 DP 759020 20 Cobbadah Street Upper Horton	Install a 20m high monopole telecommunications tower and associated infrastructure	\$88,000	✓	

There were no Development (DA) or Development Modification (s4.55) applications approved in a previous month but not previously reported to Council.

There were no Development (D/A) or Development Modifications (s96) application(s) refused (R), withdrawn (W) or cancelled (C) during the month of April 2024.

There were no Development (D/A) applications determined where there has been a variation in standards under clause 4.6 of the Gwydir Local Environmental Plan 2013 during the month of April 2024.

The following table shows all Development (D/A) and Development Modification (s96) applications that were submitted on the NSW Planning Portal, that were lodged

with Council after the payment of lodgement fees and those that remain unlodged with Council, during and prior to 30 April 2024 and remain undetermined at the end of April 2024:

Application No.	Applicant Name	Property Owner	Property Address	Description of Work	Date Application submitted on the NSW Planning Portal	Date Lodged with Council	Reason for time between submission & lodgement	Current Status of the Application	Type of Application
24/2023	Revolution Town Planning	Gwydir Shire Council	33-35 Maitland Street Bingara	Modification of conditions of approval	7/02/2024	27/02/2024	Awaiting Payment of Lodgment Fees	Being assessed by independent planning consultant	Modification
29/2023	SMK Consultants	Gwydir Shire Council	32 Plunkett Street Warialda	Continued Use of two additions three-bedroom dwelling to be used for professionals' accommodation	14/06/2023	28/08/2023	Request a Statement of Environmental Effects that reflects the continued use of the building already placed onsite rather than for the construction of them	Reported to May 2024 meeting for determination	DA
42/2023	B J Davis	B J Davis	1246 Mosquito Creek Road Warialda	2 Lot Rural Subdivision	22/09/2023	-	Request Additional Information		DA
47/2023	V L'Or	V L'Or	26 Frazer Street Bingara	Modification of existing approval for 3-bay shed to include a bathroom	25/03/2024	10/04/2024	Invoice for fees issued and awaiting payment prior to lodgement of application	Being notified & exhibited for 14 days as per Community Participation Plan	Modification
48/2023	Revolution Town Planning	Gwydir Shire Council	33-35 Maitland Street Bingara	Office Building and Community Facility	9/11/2023	22/02/2024	Request Additional Information	Regionally Significant Development - Awaiting acceptance by Regional Planning Panel	DA
02/2024	Jesse Rollings	J Rollings & C Jones	134 Long Street Warialda	Modification of existing approval for a open shed due to new design to a partially open shed	29/04/2024	-	Pre-lodgement Review being undertaken	-	Modification
05/2024	Upper Horton Feedlot (D L Hamilton, P J Hamilton, S T Hamilton & J L Randall)	P J & D L Hamilton	2983 Horton Road Upper Horton	999 Head Cattle Feedlot	16/01/2024	22/02/2024	Invoice for fees issued and awaiting payment prior to lodgement of application	Request of amended Statement of Environmental Effects	DA

08/2024	J E Hardcastle	Hardcastle Pty Ltd	18-22 Wilby Street North Star	Amalgamation of three existing urban allotments into one urban allotment	13/02/2024	-	Request of amended Statement of Environmental Effects prior to lodgement		DA
12/2024	Warialda Motor Sports Club	Bryan R S & Beverley M Basham, Stephen J & Kerrie P O'Rourke, Amanda P & Trevor J Willams & Colin R McQueen	2953 & 2519 Gragin Road Warialda	Continued Use of property for annual Warialda 200 Off-Road Racing Event	23/03/2024	18/04/2024	Invoice for fees issued and awaiting payment prior to lodgement of application	Being notified & exhibited for 14 days as per Community Participation Plan	DA
13/2024	D Anderson	M R Densely	12 Long Street Warialda	11.5m x 12m 3-bay garage	2/04/2024	8/04/2024	Invoice for fees issued and awaiting payment prior to lodgement of application	Being notified & exhibited for 14 days as per Community Participation Plan	DA
14/2024	S & E Doodson	N J Roberts	679 Michells Lane Whitlow	Three Lot rural subdivision	2/04/2024	15/04/2024	Invoice for fees issued and awaiting payment prior to lodgement of application	Being notified & exhibited for 14 days as per Community Participation Plan	DA
15/2024	RuralCert Pty Ltd	T O E & C Smith	Elcombe Road Bingara	Single Storey Dwelling, detached garage and detached 3-bay shed	10/04/2024	16/04/2024	Invoice for fees issued and awaiting payment prior to lodgement of application	Being notified & exhibited for 14 days as per Community Participation Plan	DA
16/2024	Gwydir Shire Council	M J Bogan & J M Kane	135 Burundah Drive Warialda	Two Lot Rural Subdivision	29/04/2024	-	Request for Additional Information - Confirmation of compliance with cl 4.6(6) of the Gwydir Local Environmental Plan 2013	-	DA

The following graph shows the Subdivision Certificates issued during the month of April 2024 and in the preceding seven months.

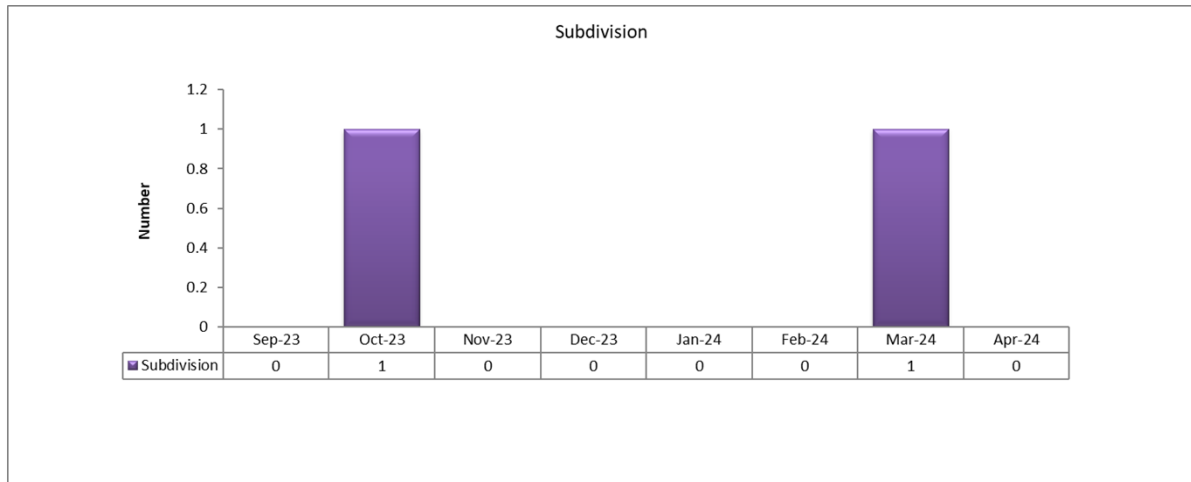

The following graph shows the Conveyancing Certificates issued during month of April 2024 compared to the previous seven months:

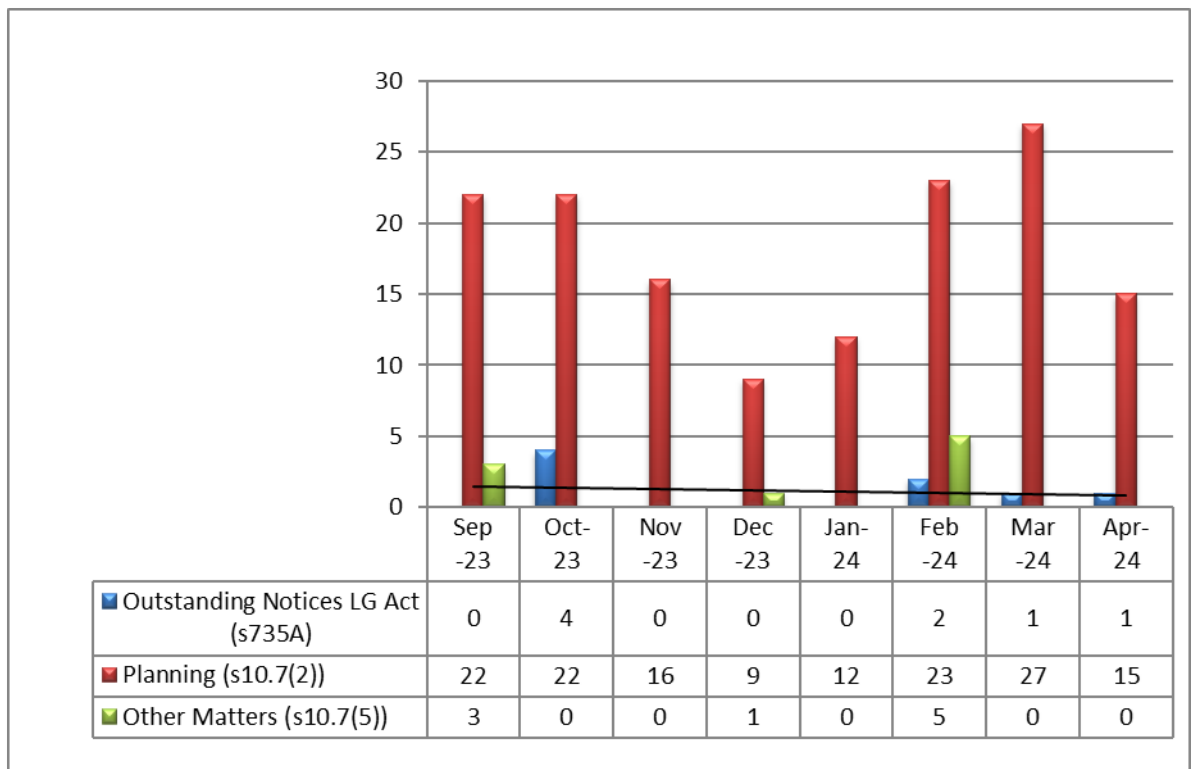

The following graph shows the Conveyancing Certificates issued up to and including the month of April 2024 compared with the same period in 2023:

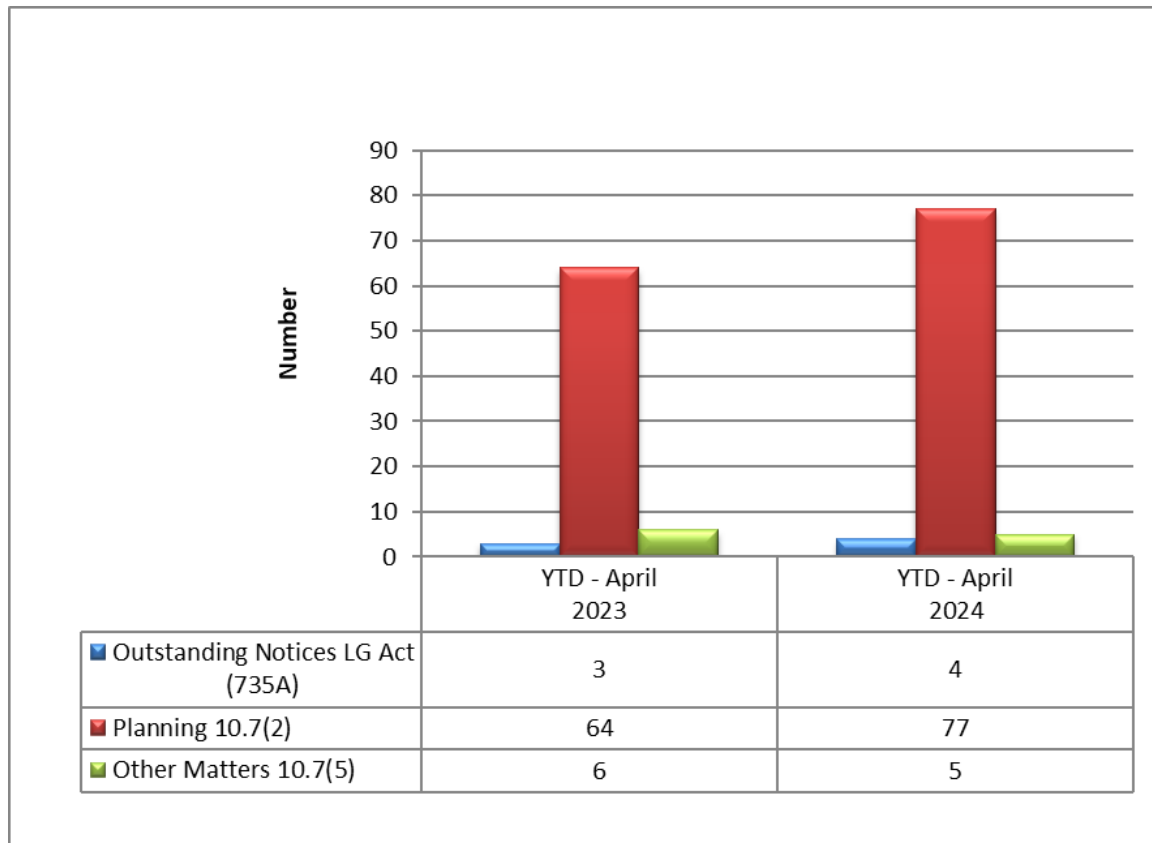

The table below shows a comparison between total development applications (excluding s4.55 modification applications) lodged during the month of April 2024 compared to the same period in the previous two years:

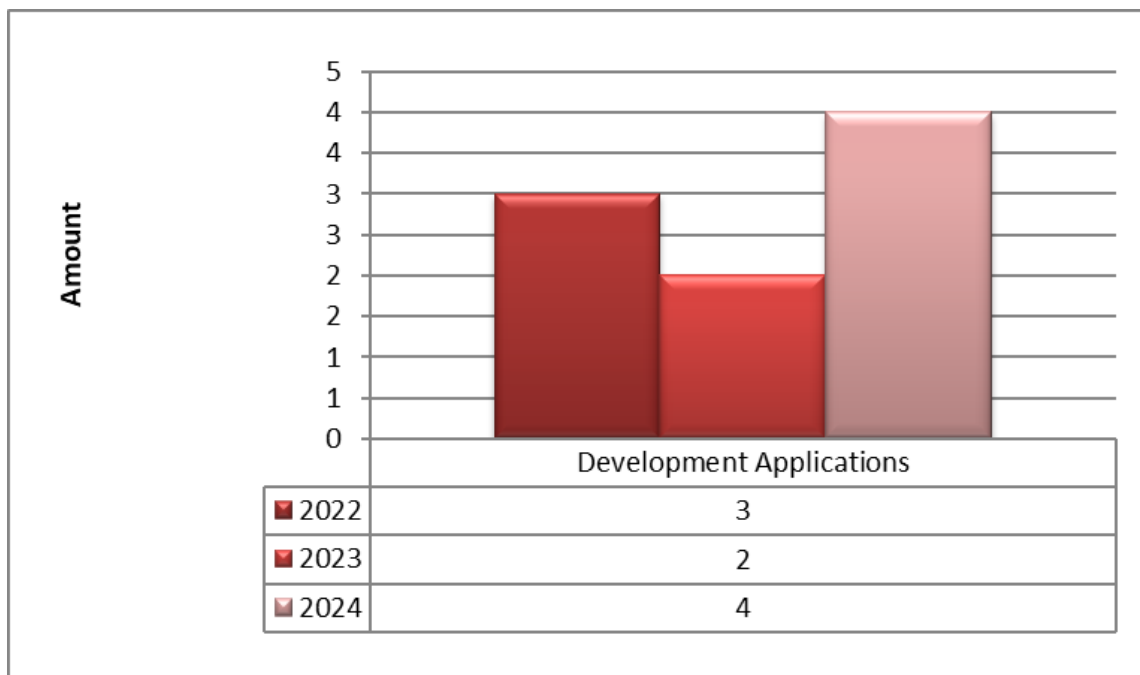

The table below shows a comparison between total value of development applications (excluding s4.55 modification applications) lodged during the month of April 2024 compared to the same period in the previous two years:

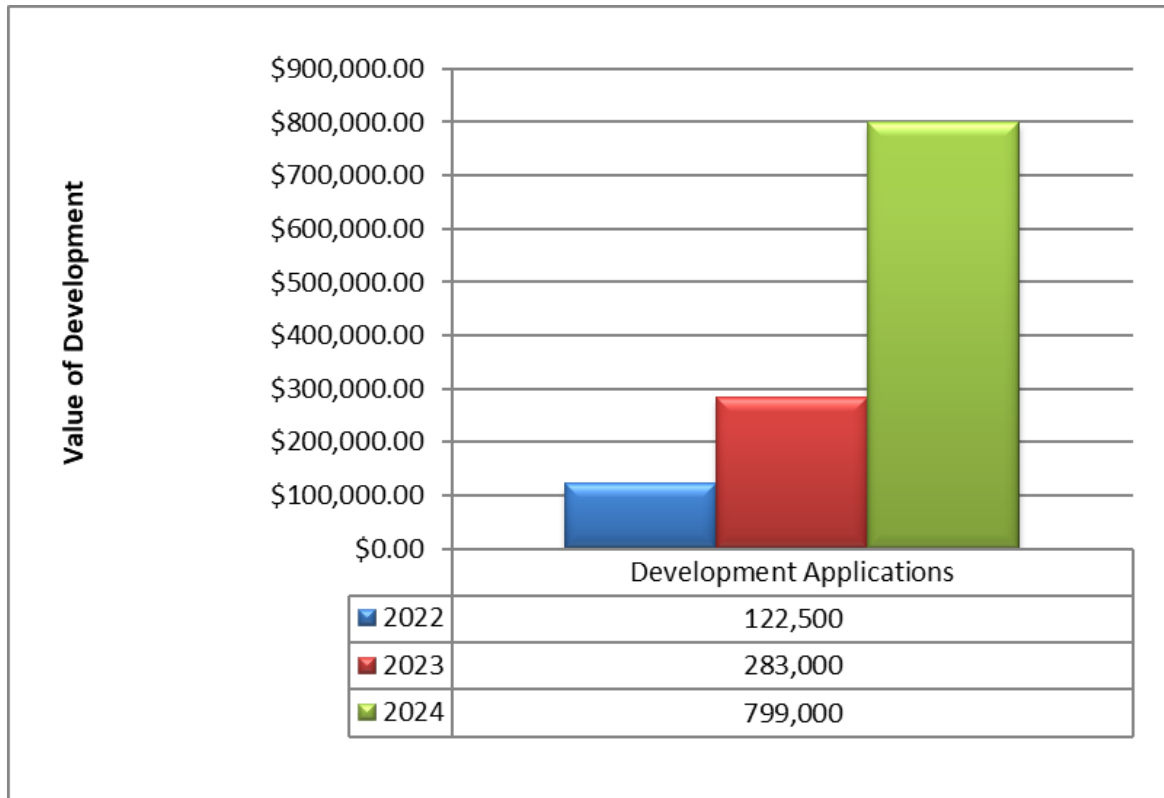

Development Applications (excluding s4.55 modifications) lodged for the year by type – YTD April 2024:

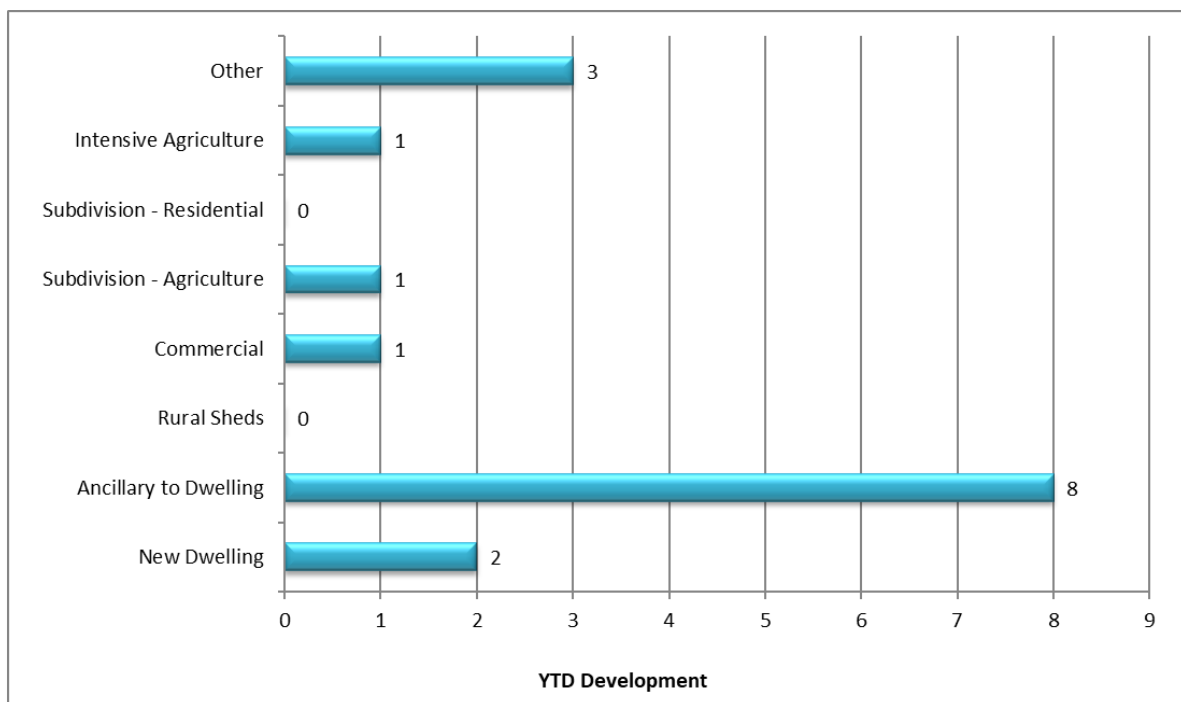

Development Applications (excluding s4.55 modifications) lodged for the year by locality – YTD April 2024:

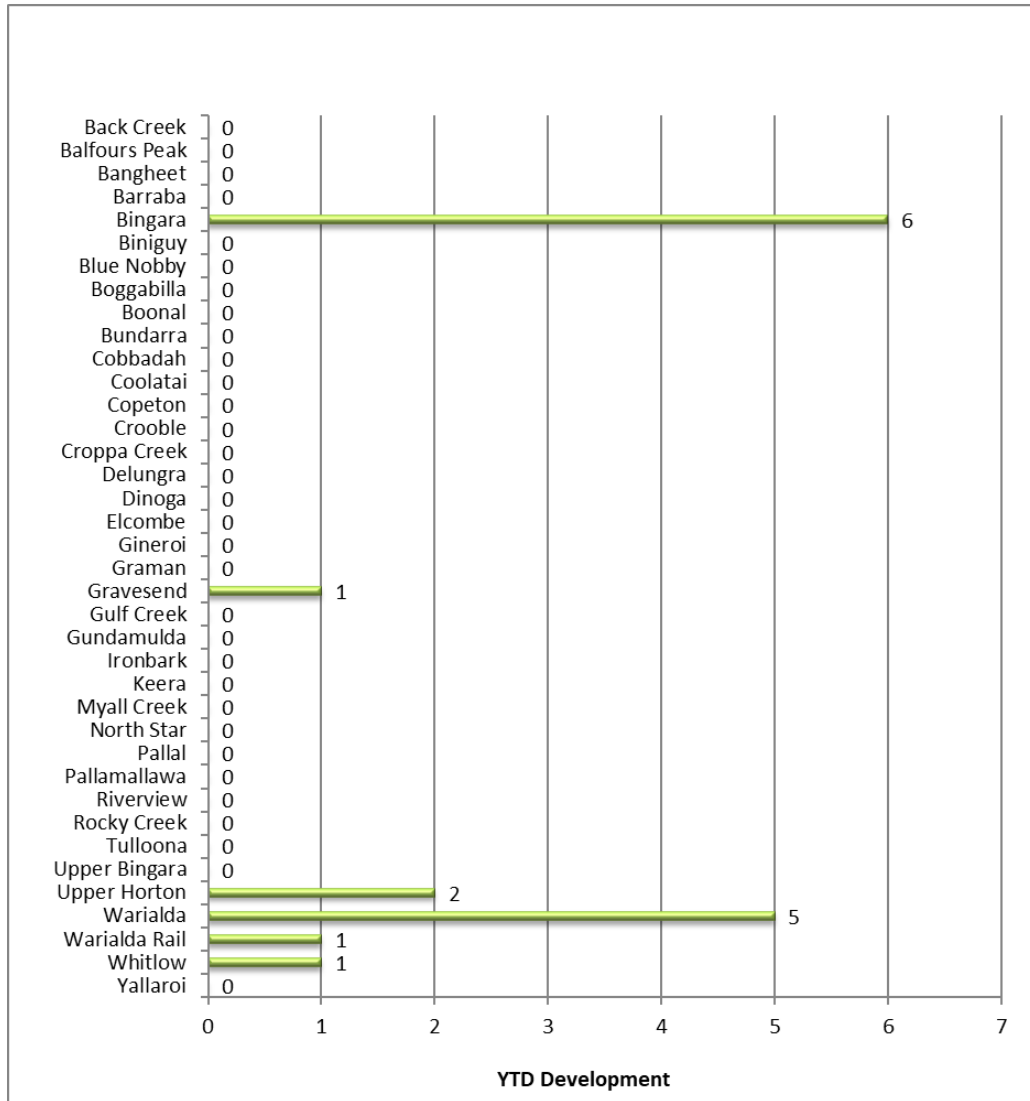

Development Application Analysis (excluding s4.55 applications) – for the nine (9) months up to the end of February 2024

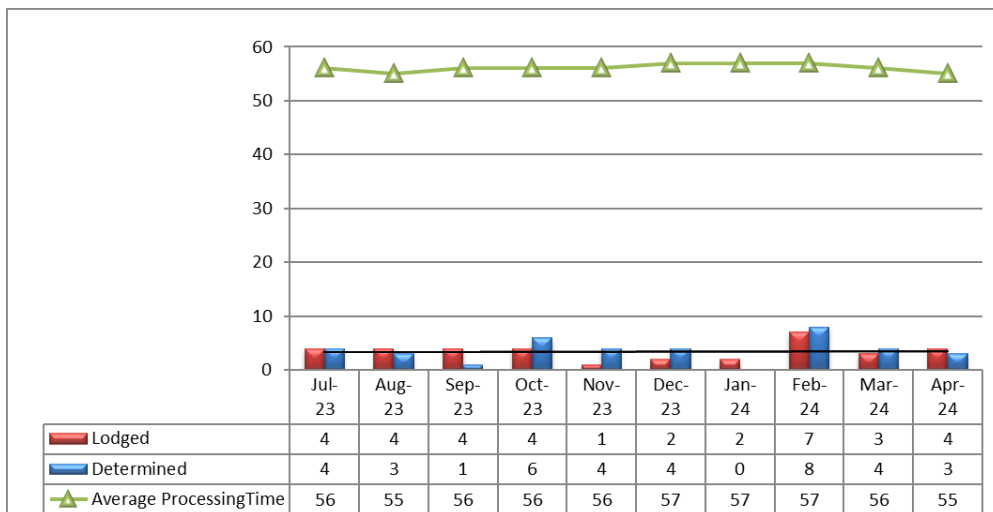

BUILDING SERVICES – APRIL 2024

The Department continues to receive enquiries and provide advice on a range of planning and building matters including:

- Minor structure construction e.g., sheds
- Commercial opportunities and construction
- Basix (Building Sustainability Index)
- Bushfire requirements
- Building construction standards and requirements
- Stormwater
- Licensing and owner builder requirements
- Fees and charges

The department is continuing to receive a high volume of applications via the NSW Planning Portal. It is mandatory that all applications for Construction Certificates (CC), Complying Development (CDC), Principal Certifier Appointments (PCA) and Building Information Certificates (BIC) be lodged with Council via the NSW Planning Portal. Section 68 (S68) Applications are lodged directly with Council.

There are currently *82 active* Construction Certificate and Principal Certifier Appointment approvals that are at varying stages of the assessment/construction process and working towards the completion, and issue of an Occupation Certificate.

The table below shows the approvals that have been issued during April 2024.

No.	Property Description	Development/Work	\$
CC 5/2022	6 Frazer Street Bingara	Alterations and Additions to existing relocated dwelling	\$65,000
CC 13/2023	26 Faithful Street Bingara	Alterations and Additions to existing dwelling	\$50,000
CC 22/2023	6226 North Star Road North Star	Telecommunications Facility	\$243,000
CC 51/2023	50 Bingara Street Warialda Rail	Shed	\$19,800
CC 3/2024	12970 Gwydir Highway Warialda	Carport	\$6,600
CC 6/2024	5 Heber Street Bingara	Attached patio/deck and detached double bay garage	\$75,854
CC 10/2024	21 Bingara Street Warialda Rail	Inground swimming pool and associated safety barriers	\$82,440
S68 2/2024	75 Riddell Street Bingara	Water supply, sanitary plumbing, sewerage and stormwater work	NA

S68 3/2024	5658 Cobbadah Road Bingara	New onsite sewerage management system	NA
------------	-------------------------------	---------------------------------------	----

NO. OF COMPLAINTS/INSPECTIONS April 2024

Type	No.	Yr. to Date	Actioned	Pending
Construction/Building & Building Maintenance	51	952	937	15

SWIMMING POOL INSPECTION PROGRAM

The *Swimming Pools Act 1992* and its regulations work together with Australian Standard 1926 (AS1926) to establish the safety standards for ‘backyard’ swimming pools.

There are 3 different Pool Safety Standards that apply in NSW, depending on when the pool was constructed:

- AS 1926-1986, fences and gates for private swimming pools which applies to pools constructed prior to 30 August 2008
- AS 1926.1 - 2007, swimming pool safety, Part 1 safety barriers for swimming pools which applies to pools constructed between 1 September 2008 to 30 April 2013
- AS1926.1 - 2012, swimming pool safety, Part 1 safety barriers for swimming pools constructed after 1 May 2013

As a requirement of the Council’s inspection program, Authorised Officers have been conducting tri-annual swimming pool compliance inspections.

A total of 52 inspections have been completed, with only 2 swimming pools and 1 spa pool being declared *Non-Compliant* at the time of the first inspection.

Inspectors were unable to gain access to 2 properties due to locked premises, additional notifications have been sent to the property owners requesting them to contact the Council as a matter of urgency.

Two swimming pools had been decommissioned and one inspection has been rescheduled to a later date due to maintenance being carried out on the pool.

All notices of *Non-Compliance* related to the following requirements.

- **Safety barriers (fencing)**
- **Warning Signs**

Owners of the pools identified to be *Non-Compliant* are notified of the inspection result and given a set period of time to rectify any issues to assure that the pool complies with the appropriate standard before any further action is taken.

All compliant pools have now been issued with a 3-year Certificate of Compliance from the NSW Swimming Pools Register.

BUILDING MAINTENANCE

The Department continues to receive requests to carry out minor maintenance and these are generally dealt with in a timely manner. Otherwise, the works are scheduled into maintenance staff building activities including new works for attention.

PROJECTS WORKED ON

Bingara Toy Library

- The Bingara Toy Library has received a makeover with internal and external painting being completed.



Bingara Toy Library - External painting completed



Bingara Toy Library - External painting completed



Bingara Toy Library - Internal painting completed

Warialda Rail Recreation Ground

- The construction of the new amenities block is progressing without any problems.



Warialda Rail Recreation Ground – new accessible amenities



Warialda Rail Recreation Ground – accessible amenities ready for cladding

Bingara Oval

- Bird proofing of the grandstand



Bingara Oval – bird proofing of grandstand

ENVIRONMENT & SUSTAINABILITY DEPARTMENT APRIL 2024

The Department continues to receive enquiries and provide advice on a range of health matters including:

- Overgrown properties
- Food premises design and fit-out
- Food handling practices
- Mobile food vendors
- Food business notification
- Pet Ownership

DRINKING WATER TESTING

The Department continues to carry out routine sample collection for microbiological and chemical testing of the water supplies in the towns of Warialda and Bingara, fortnightly sampling of Gravesend and monthly sampling at North Star.

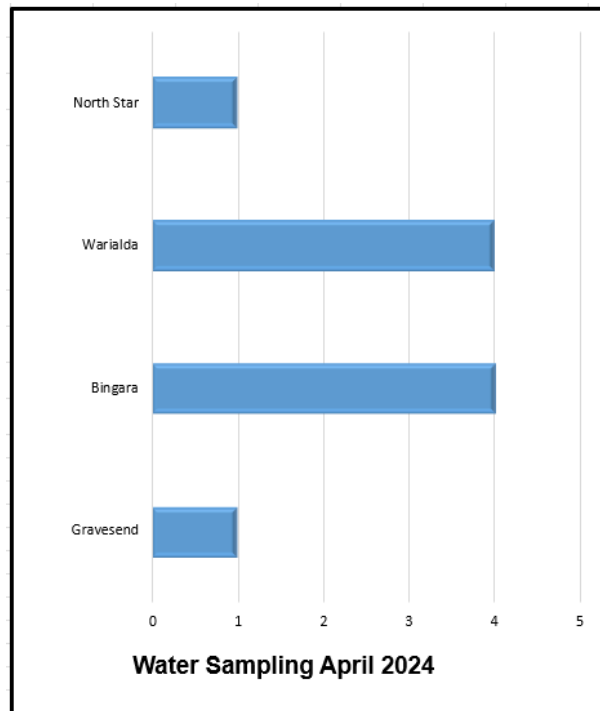

FOOD INSPECTIONS

Food Premise Inspections are carried out on an annual basis for each food business. There are approximately 40 registered food service businesses within the Council area including supermarkets, clubs/pubs, motels, bakeries, cafés and takeaway food shops, mobile food vendors and school canteens. Depending on the nature of the food being served some businesses are exempt from inspection unless a complaint or issue arises.

The graph below shows inspections that have been carried out for the current financial year.

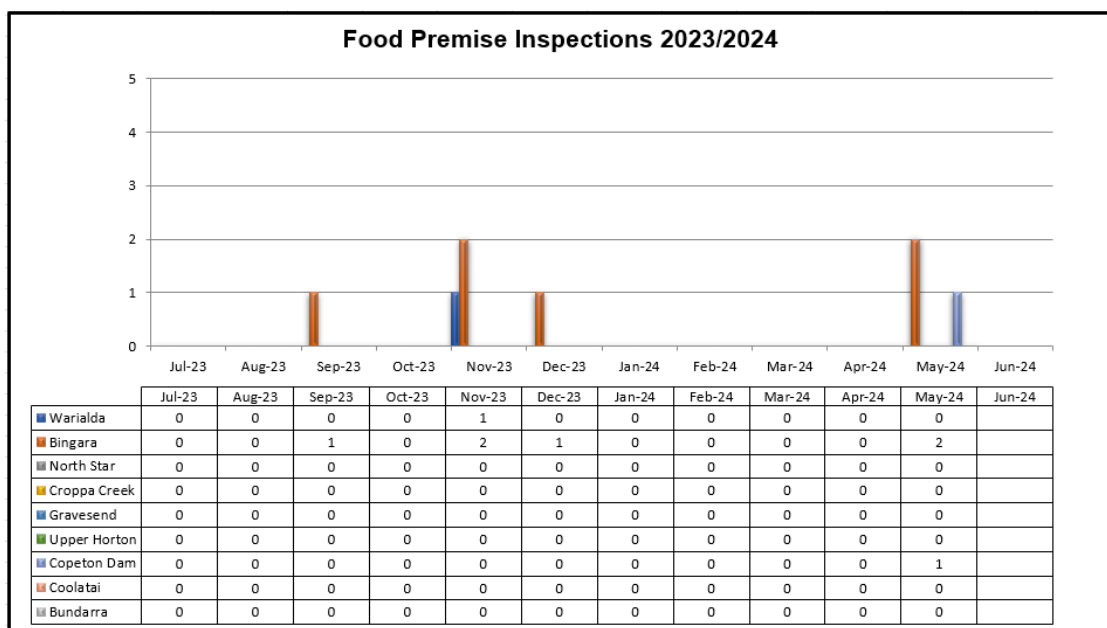

COMPLIANCE AND REGULATORY CONTROL

Council has received customer requests regarding overgrown blocks, roaming dogs, roaming stock, noise, the keeping of animals and other concerns during the month of March 2024. These are investigated and actioned as necessary.

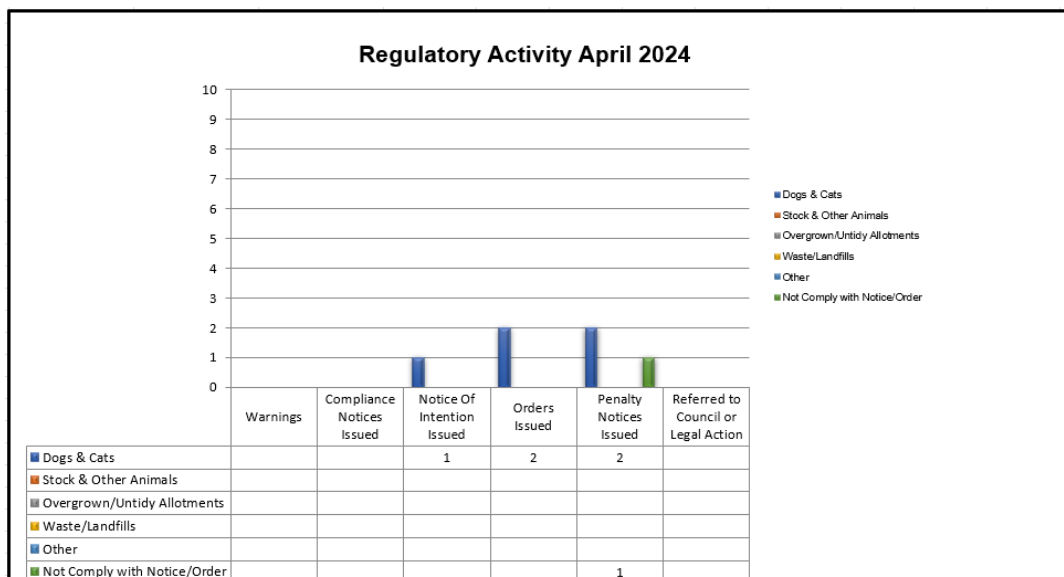
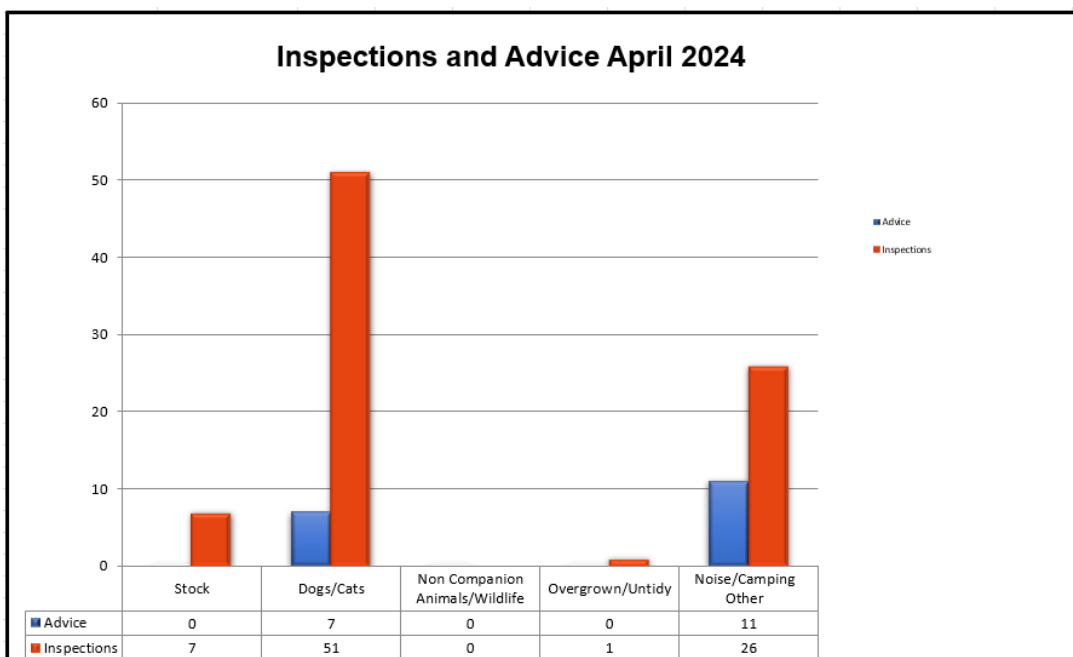
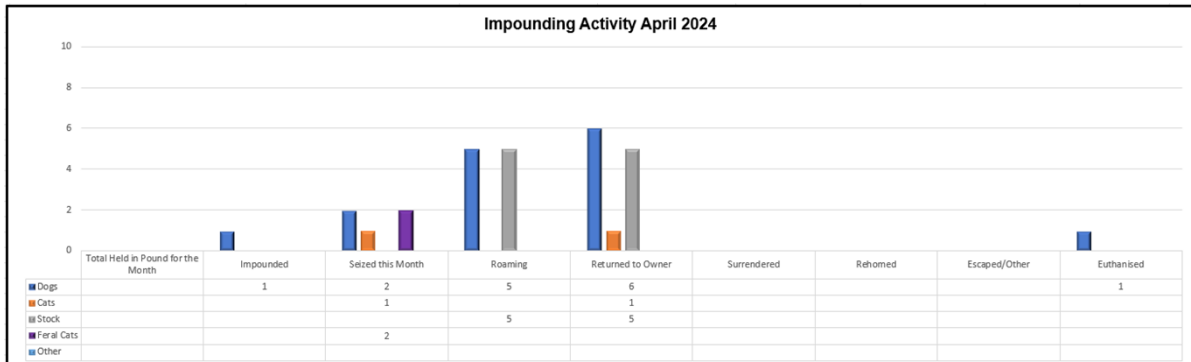

RIVERSIDE CAMPING

Council’s Compliance Officers aim to carry out daily checks along the river to ensure that camping is being conducted in a safe and hygienic manner. Flyers promoting local events and services are distributed to campers and enquiries from campers are addressed as required. The graphs below show total numbers of campers and the distribution of campers at the different campsites.

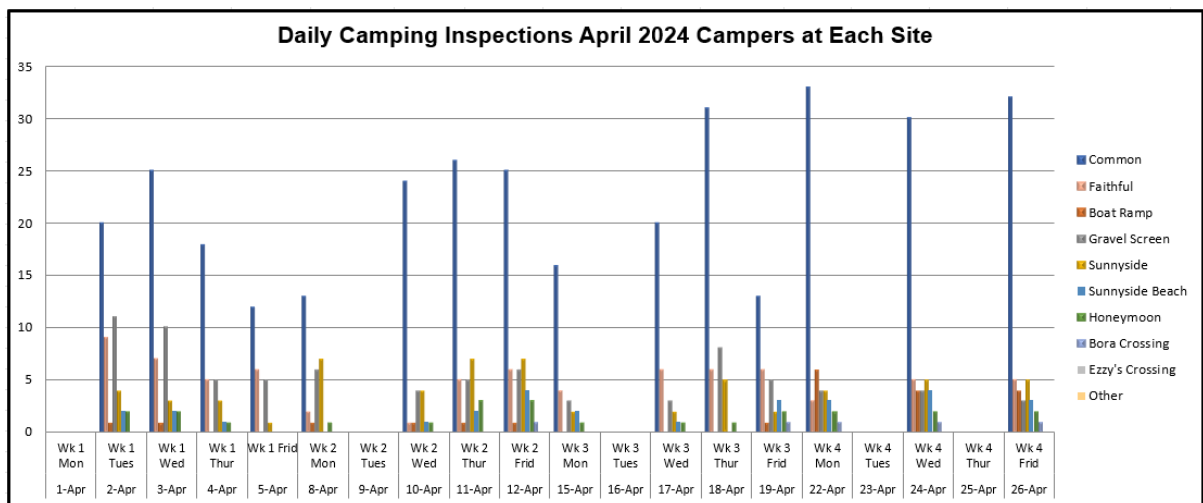
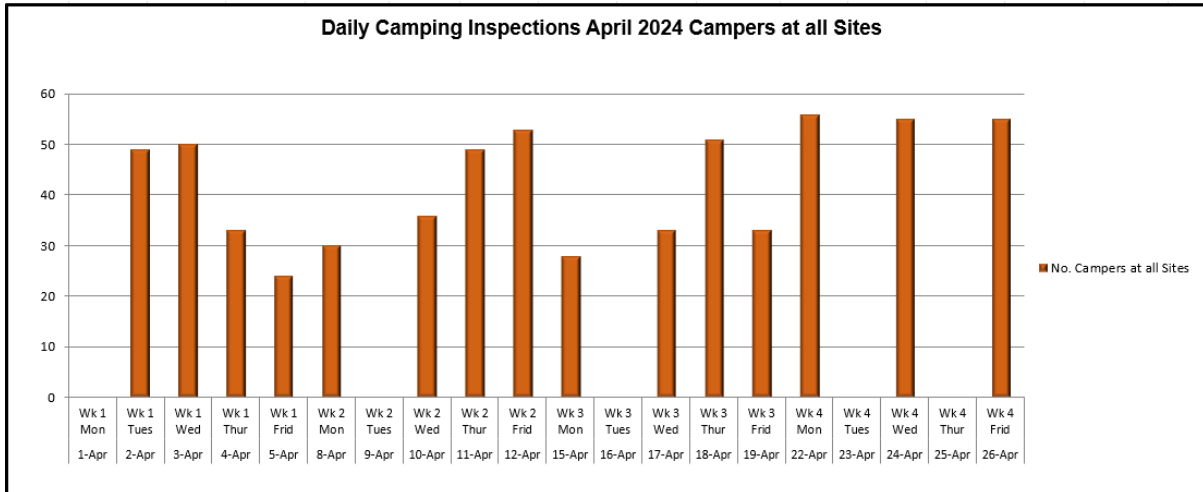

CAMPING AREA DONATIONS COLLECTED

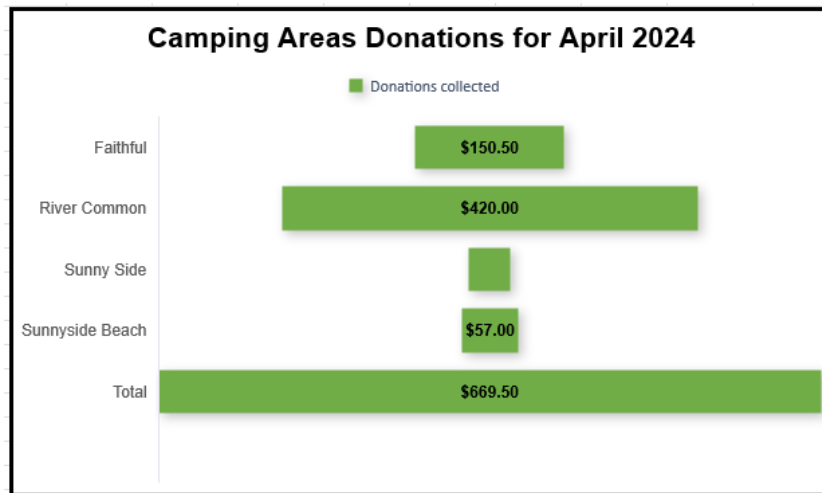

WARIALDA KOALA MATTERS

Council has installed a donation box at the Warialda Koala Park. All donations collected will go towards the North West Koala A.R.K.S Group. A sign will soon be added with information about where the donations are going, and a QR code for electronic donations.



LANDFILL REPORTS

Bingara and Warialda – Tyre cages are working well at both sites. Sites remain tidy and accessible.

Warialda Rail – Untidy at the moment, Shire staff will push up general waste this week.

Gravesend – Filling up fast, need to utilize this area for timber crushing to create more space.

Coolatai – Easily accessible but will need a push up in the next couple of weeks.

Croppa Creek – Accessible and tidy. After recent fire a large amount of steel can be seen in the pit, efforts will be made in the future to remove.

Upper Horton – After recent fire the landfill was cleaned up by Dave Whatman and remains tidy and accessible.

North Star Transfer Station – Transfer station running smoothly now, still some large items being put in bins.





Figure 2 - Warialda Rail



Figure 3 - Gravesend



Figure 4 - Croppa Creek



Figure 5 - Upper Horton

The Planning & Environment Department report for April 2024 was compiled with the information available at the time of preparing the report.

Community Assets

Gwydir Libraries

Statistics – March 2024	Bingara	Warialda	Gwydir
-------------------------	---------	----------	--------

Door Count	1793	710	
Loans	1073	850	
New Members	12	6	
E-resource Users			88
Downloads			142
PC usage	217	108	
WIFI usage	460	260	
Programs	51	25	
Adult Program attendees	204	119	
Children Program attendees	279	88	
Home Delivery	12	4	
Institution Delivery	5	2	
Seniors Be Connected sessions	16	8	
Community support hub	24	12	
Statistics – April 2024	Bingara	Warialda	Gwydir
Door Count	1585	945	
Loans	1106	850	
New Members	9	4	
E-resource Users			68
Downloads			135
PC usage	231	165	
WIFI usage	460	288	
Programs	37	23	
Adult Program attendees	186	146	
Children Program attendees	230	94	
Home Delivery	10	4	
Institution Delivery	4	2	

Seniors Be Connected sessions	16	8	
Community support hub	31	18	

Bingara Library

- Seniors’ Film Afternoons and Kanopy tutorials are proving to be very successful, Seniors learning about streaming services which are available through their membership. Seniors’ Film Afternoons are held on the second and fourth Friday of each month.
- Be Connected Internet Tutorials are well attended with Seniors learning about new sites and Apps.
- Residents of Touriandi Lodge visited the library to borrow items, chat with friends while enjoying morning tea.
- Council development staff meet members of the community in the library regarding DA applications and approvals.
- Community Hub assistance is offered to Seniors, assistance varies from mobile phone assistance to completing basic forms.
- Volunteers are enjoying the role and learning more about public libraries.
- Staff and Volunteers attended the community information day, ‘Bingara’s Heartbeats’ at Gwydir Oval on 16 March 2024. This was a great morning showcasing what the library offers along with residents being able to speak to our Volunteers.
- After school programs continue to be well attended, Lego Club remains the most popular program.
- Bingara Community Op Shop held their fashion parade in the Bingara Library on 9 March 2024.
- Book Club meet on the first Friday of each month. Club membership is continuing to grow.
- Writers’ Group meet every Thursday.
- Seniors’ games morning each Wednesday from 10.30am.
- Home schoolers Group visit each week.
- After school programs continue to be successfully attended.

Warialda Library

- Senior Assist programs which are held every Tuesday and Thursday. These programs are well attended. These programs involve assisting seniors with computers.
- Seniors’ Craft Group are held every second Wednesday.
- Story time at Toy library continues to be successful.
- Golden Oldies at Naroo Residents craft and tutorials monthly.
- Home Schoolers Group visit Wednesday of each week
- After school programs continue to be successfully attended.
 - The local Bridge Club held lessons in Library during April.
 - An ANZAC Craft Session was held at Naroo where the seniors made poppies. Volunteer Charlotte crocheted 36 poppies for the residents! The Senior Craft Group also crocheted Poppies.
 - School Holliday activities for children (6 to 12 years) saw a scavenger hunt at Captain Cook Park and an ANZAC biscuit cooking session.

During the reporting period library staff completed mandatory food handling and food safety training. Staff also attended regional training in Tamworth.

Events

During the reporting period submitted the following Event Management Plans to Council's insurance company for review. All events were held.

March

- Bingara's Heartbeats – Volunteer Day – 16 March 2024
- Bingara Angler's Club Easterfish – 29 March to 31 March
- Warialda Anzac Day March – 25 April 2024
- Gravesend Anzac Day March – 25 April 2024
- Bingara History Story Telling – 22 May 2024

April

- Coolatai Tractor Pull – 18-19 May 2024
- Whalebone – 27 April 2024 (Council Event)

Upcoming events

FABBA – The Roxy – Saturday 10 August 2024 – fundraiser for Gwydir Country Education Fund.

Grazing on the Gwydir – Saturday 31 August 2024.

To find more events across the Shire go to Council's Events website page.

Social Media Posts

Naroo Hostel are running a bed replacement program. A post was published to the Gwydir Shire Council Facebook page on 13 March 2024 which encouraged anyone interested in making a small donation to obtain an existing bed when the new ones arrive to contact the facility. The post reached 1468 people.

Council published a post on 12 March 2024 seeking Community Consultation for the Naming of Nicholson Oval Amenities and Canteen Building on the Gwydir Shire Council Facebook page. The post reached 1424 people with 748 people engaging with the post. Submissions were encouraged to be submitted to Council via post or email by Tuesday 2 April 2024.

Scheduled on 9 April 2024, the Community Meetings post reached 2,937 people on Council's Facebook page.

On 23 April 2024, a FABBA poster was published to Council's Facebook page, this post reached 3,893 people. Also occurring on 23 April 2024, Council advertised the General Plant Operators and Labourers position which reached 3,187 people.

It should be noted that these scores reflect just the Gwydir Shire Council Facebook page but are shared to other Council social platforms to increase awareness.

Design Work

- S355 Committee of Council – Flyer
- What's On – Flyer
- Gwydir Pools Update – Season Closure - Social Tile
- Croppa Creek Anzac Day – Social Tile
- Warialda Anzac Day - Flyer

- Happy Easter – Social Tile
- Office Hours and Service Provisions – Easter - Social Tile
- Maitland Street, Bingara – Public Amenities Reopened – Social Tile
- Naroo Bed Replacement – Social Tile
- Public Amenities Closure – 48-50 Hope Street, Warialda – Social Tile
- Bingara Community Op Shop Welcomes New Volunteers – Poster
- Naming of Nicholson Oval Amenities and Canteen Building – Social Tile
- Roxy and the Living Classroom Calendar
- Warialda Caravan Park Map - Sign
- 2 x Job Adverts – Social Tiles
- ANZAC Day Services – Social Tile
- Bingara Book Club – Poster
- What's On – Poster
- Library Signs
- Caravan Park Signs
- FABBA – Poster
- Grazing on the Gwydir – Poster
- Surplus Items and Equipment Sale – Social Tile
- Community Meetings – Poster and Social Tile

Gwydir News

Council continues to contribute content and advertise in each monthly edition of the Gwydir News.

GLR Training

Heavy Vehicle Training and Assessment

Heavy vehicle training and assessment has remained consistent during March and April 2024 with eight (8) clients completing their training and final competency assessments, providing them with the requirements to upgrade their driver licence.

Training Services NSW has advised that Agskilled funding via the Smart and Skilled (S&S) program has been exhausted for the current activity period, therefore GLR Training will not receive S&S funding for clients until next financial year.

In an effort to overcome some of the obstacles created by the new Smart and Skilled guidelines, and provide clients with greater opportunity, GLR Training has increased its scope to include the following units of competency:

- TLIC3004 – Drive Heavy Rigid Vehicle
- TLIC3005 – Drive Heavy Combination Vehicle
- TLIC4006 – Drive Multi-Combination Vehicle
- TLILIC2014 – Licence to Drive a Light Rigid Vehicle
- TLILIC2015 - Licence to Drive a Medium Rigid Vehicle
- TLILIC2016 - Licence to Drive a Heavy Rigid Vehicle
- TLILIC3017 - Licence to Drive a Heavy Combination Vehicle
- TLILIC3018 – Licence to Drive a Multi-Combination Vehicle

Registered training organisations have been advised that the department anticipates offering Smart and Skilled Review Notices to eligible providers for the 2024-2025 Activity Period in early May. The offer and acceptance process will be open for two weeks.

January - April 2024 Heavy Vehicle Training statistics are as follows:

	Enquiries	Applications for S&S Funding Submitted & approved	Paying Clients	Training completed	Future bookings
January 2024	5	2	0	1	5
February 2024	7	4	1	5	3
March 2024	11	3	1	4	2
April 2024	5	NIL - Funding exhausted	2	4	2

Learner Driver Lessons

Learner Driver Lessons	Jan	Feb	Mar	Apr
	0	2	0	3

In an effort to increase participation, GLR Training has recently launched a campaign offering students at both Warialda High School and Bingara Central School two learner driver sessions for the price of one *special*.

Gwydir Career Start Program

The following table outlines the subsidies claimed by Gwydir Shire Council for current trainees and apprentices. These figures include *Boosting Apprenticeship Commencements wage subsidy*, *Completing Apprenticeship Commencements wage subsidy*, *Priority Wage Subsidy* (The Priority Wage Subsidy is a wage subsidy for employers of Australian Apprentices training towards an occupation listed on the Australian Apprenticeships Priority List. Employers can claim 10% of wages paid to the Australian Apprentice for the first and second 12-month period (up to \$1,500 per quarter) and 5% of the wages paid to the Australian Apprentice for the third 12-month period (up to \$750 per quarter), and *Hiring Incentive* (The Hiring Incentive supports Australian Apprentices undertaking a Certificate II or above qualification that is not listed on the Australian Apprenticeships Priority List. A payment of \$1,750, for a full-time Australian Apprentice and \$875 for part-time Australian Apprentice is made at 6 and 12 months.)

Period	No. of employees	Claimed/Paid
01/07/2023 – 30/09/2023	13	\$15,272.76

1/10/2023 – 31/12/2023	5	\$3,343.94
1/01/2024 – 31/03/2024	16	\$25,292.70
01/04/2024 – 30/04/2024	0	-
Total		\$43,909.40

The NSW VET Review

The NSW Vocational Education and Training Review is a comprehensive examination of the vocational education and training sector focused on identifying the strengths, gaps and opportunities for improvement in skills development and training, to support students and the workforce.

The NSW Government asked the independent panel to focus the interim report on TAFE NSW. The report recognises that Smart and Skilled providers remain an integral part of the delivery of diverse training that supports reskilling of the workforce across the state and helps address skills shortages.

The interim report can be found at: <https://education.nsw.gov.au/about-us/strategies-and-reports/our-reports-and-reviews/nsw-vocational-education-and-training-review>

The final report is expected to be delivered in mid 2024.

There are no changes to Smart and Skilled contracts for the remainder of the current contract period. Review Notices for 2024-25 Smart and Skilled Contracts will be offered by 30 April 2024, in accordance with the Smart and Skilled Contract Terms and Conditions.

Gwydir Country Education Fund (GLR CEF)

GLR CEF is providing financial assistance to eight local students in 2024. Recipients are able to claim reimbursement for education related expenses including laptops, computer accessories, textbooks, uniforms and work boots, fuel and accommodation. Total funds distributed in 2024 - \$7,030.72.

Warialda Public School, St Joseph’s Catholic School, Warialda High School, Bingara Central School, and Bingara Preschool participated in the Gwydir CEF ‘Bootbash’ fundraiser on Friday 15th March 2024 where students, teachers and volunteers were encouraged to ‘wear their boots to school’ and make a gold coin donation. Total funds raised \$492.00:

Warialda Public School	\$225.00
Warialda High School	\$70.00
St Joseph’s Catholic School	\$31.00
Bingara Preschool	\$24.00
Bingara Central School	\$106.00
GSC Warialda	\$36.00

Cranky Rock

Camping statistics:

	January 2024	February 2024	March 2024	April 2024
Powered Sites	29	35	73	70
Unpowered Sites	13	17	26	34

Gwydir Swimming Pools

Both Bingara and Warialda swimming pools are now closed for the season. Leading up to the end of March pool mats were utilised when the prior day was less than 26°C.

Thursday 28 March 2024 marks the end of an era with Allan Colley announcing he is hanging his towel up for the last time after 16 years as Pool Manager with his wife, Danni.

Allan’s skill, knowledge and passion has benefitted hundreds of children over his 16 years at Warialda, with not only local swimmers taking advantage of his expertise, but also many families travelling from surrounding areas to join his daily training sessions.

Allan provided the following comment on the Warialda Swim Centre Facebook page:

It’s not just a wrap on the season, it is also a wrap on my 16 years as pool manager for the Warialda Swim Centre.

Thank you to all of our swim teachers for their hard work, to the people of Gwydir Shire for their continuous support, to Gwydir Shire Council for a great relationship over the years, and finally to our visitors from Moree Plains and most recently Inverell Shires.

However, all good things must come to an end. I’ve decided it’s time to pass the torch on to someone else and retire. I’m off fishing!

I wish everyone the very best, and hope our swimmers stay swimming. Thank you everyone once again! And remember - there’s no running on the cement, don’t touch the swim flags, and most importantly, stay off the bloody lane ropes!

Entry numbers for the 2023-24 swimming season:

	October 2023			November 2023			December 2023		
	GSC Residents	Visitors	Total	GSC Residents	Visitors	Total	GSC Residents	Visitors	Total
Warialda			1533	2820	420	3240	1930	128	2058
Bingara	2416	255	2671	2110	81	2191	3220	250	3470
	January 2024			February 2024			March 2024		
	GSC	Visitors	Total	GSC	Visitors	Total	GSC	Visitors	Total

	Residents			Residents			Residents		
Warialda	2335	300	2635	4113	600	4713	2190	65	2255
Bingara	3668	419	4087	3368	115	3483	2108	65	2173

Upgrades at the Warialda Swimming Pool have commenced with North West Floor Sanding installing a six coat hyper flake epoxy system to the kiosk, office and kitchen floor. High Style Furniture and Kitchens are scheduled to commence the installation of cabinetry and benches in the kiosk on Tuesday 6th April 2024. Additional works include repainting, installation of doors on changerooms in female amenities, replacement of safety signage, beautification of building façade, construction of shade shelter.

The upgrades are funded from the State Governments Stronger Country Communities Program and the Federal Government Local Roads and Community Infrastructure (LRCI) Program.

The electricity supply upgrade at the Bingara Swimming Pool which will include the installation of sporting lights, the heating pumps, clock, and lap timer) will take place during August 2024. All compliance issues and approvals have been obtained and installation works are booked in, and ready to commence.

Aged Units

All aged units at Holden and Plunkett Streets Warialda and Whitfield Place, Maitland Street Bingara, are occupied.

8 Olive Pyrke Terrace, Warialda

Local real estate agents were contacted and asked to provide a market appraisal for the Council owned property located at 8 Olive Pyrke Terrace, Warialda. The property is listed for sale for \$500,000.

The property is still leased.

Public Amenities – Corner Hope and Stephen Streets

The public amenities situated on the Cnr Hope and Stephen Streets were closed to the public on 31 March 2024. Due notice was given to the public through signage and social media posts.

Rural Doctors Network Bush Bursary Program 2024-25

Gwydir Shire Council has received an invitation to participate once again in the 2024-25 Bush Bursary Program. The program seeks to foster rural health exposure and experience amongst medical, nursing, and midwifery students.

The Bush Bursary Program is funded by rural Councils across NSW and administered by the Rural Doctors Network (RDN). It offers selected students an invaluable opportunity to undertake a two-week rural immersion experience in country NSW during their university holidays.

Participating Councils play a vital role in the program by organising accommodation,

ensuring the safety and success of the placements within their respective LGAs, and, ideally, using their firsthand experience of the area to develop an engaging and immersive placement itinerary for the students.

Selected students receive up to \$1,500 each to assist with placement-related expenses, including travel, meals, and discretionary spending. The two-week placements typically occur between November and January and are coordinated by participating councils in collaboration with RDN.

The Living Classroom

The connection of the electricity supply to the cabins is proving to be extremely frustrating with progress slow. Essential Energy still needs to provide connection and design approval. It is hoped that the cabins will be able to be occupied by August 2024.

Northern Slopes Landcare Association (NSLA) continue to manage and coordinate a community nursery from TLC. To date NSLA staff and volunteers have:

- Developed a postcard to provide to people who purchase plants with information about the nursery and requesting pots be returned for reuse.
- Attended two Bingara Lions' Markets (March and April) with great success and support from both locals and visitors.
- Continued to propagate natives and vegetables with bought, donated, and collected seeds.
- Purchased a pallet of potting mixes.
- Established a group of core volunteers who attend the nursery every Tuesday.
 - Delivered a workshop of plant identification and survey techniques training with Dave Carr from Stringybark Ecological. It was a sold-out event and it gained great feedback from attendees.
-

NSLA advises that they hope to:

- Continue sales at Bingara Lions' Markets including the Orange Festival.
- Develop and market 'packs' e.g. Pollinator packs, Shelter belts packs.
- Continue improving our market/sales signage.
- Expand its plant range.
- Establish and maintain a kitchen garden for our excess plants using Council's VeggiePods.
- Revamp the irrigation system in the main nursery.
- Explore opportunities for growing bush tucker plants

During the reporting period the firepit area at TLC has been renovated. The existing timber seating logs have been replaced with sandstone blocks, and area levelled.

Roxy Complex

Stormwater and drainage project

The externally funded project of resolving the storm and heavy rainwater damage which occurs within the Complex building (as seen on the night of the Councillor Christmas party) is progressing.

Council staff met with an external engineer. The engineer then inspected the site, investigated the building and nearby street infrastructure (including stormwater pipes and pits) and developed a concept plan and detailed site drainage plans.

The project will see sections of roof guttering replaced, larger downpipes fitted, an extended underground drainage system installed around the building and in Cunningham Street, and larger stormwater pits installed.

These works will be undertaken by an external contractor so the project will take some time as Council will have to go through the procurement processes required and find a suitable and available contractor.

Roxy Trade Training Hospitality Centre

The Bavarian Mama owner has advised that she will no longer be using the kitchen.

Roxy Performances

Council hosted and promoted a children's show Whalebone on Saturday 25 March 2024. There were 45 attendees which was disappointing.

A report will be submitted to the Council June Ordinary Meeting of all of Council's performances at The Roxy during the 2023/2024 calendar year including attendance numbers, and detailed costings.

Roxy Café

To date the lease of the Café has proven to be positive for the lessees, Council, and the community. The tenants are incredibly happy in the Café and are positive advocates for the community and Council.

The cool room which Council purchased from Fresh Finds has been successfully removed from the fruit shop premises and is currently being stored safely at The Living Classroom.

The Roxy Complex and The Living Classroom

Both venues continue to be well utilised and presented to a high standard. See attached March and April calendars as to use.

Bingara Riverside Project

Council obtained a Short-Term Licence from Crown Lands. This Licence includes conditions required by Department of Primary Industries – Fisheries.

Council has engaged Soil Conservation Service to manage the project and undertake works. Currently Soil Conservation Service staff are finalising the site design.

The Fairy Tree and a second submerged tree were removed by contractors engaged by Soil Conservation Service.

The timber will be removed from site and stored by Council. At some point Council may mill some of the timber.

The project will see:

1. Rock revetment placed along the riverbank from downstream of the river to opposite the swimming pool entry point.
2. Installation of a rock drop structure to convey overbank flow – downstream from the bridge.
3. Construction of two rock groynes.
4. Levelling and draining of the recreational area adjacent to the river, and native plantings.

5. Construction of an extension to the existing cement footpath to the two rock groynes.

6. Construction of a terraced picnic area (approx. 44 metres long), and

Caravan Parks

Warialda

Community Assets staff were managing the park from 21 December 2023 to end April 2024.

From 1 May 2024 the park is leased to Allan Austin and Fiona Bayliss. Council staff assisted Allan and Fiona through a transition one week period.

Bingara

At the end of April, a family moved into the onsite residence. They will lease the residence for a six-month period. During this period the tenants will manage after hours enquiries and bookings.

North Star

The North Star Caravan Park continues to be managed by the owners of the Vicarage Café.

The Councillors' activity schedule for April 2024

April 2024		
Councillor	Event	Date
Cr John Coulton (Mayor)	Budget Workshop – Warialda	11 April
	BROC Meeting Stanthorpe	12 April
	Ordinary Council Meeting - Warialda	18 April
	ARIC Meeting	22 April
	Naomi Regional Job Precincts – Council Update	22 April
	Anzac Day Ceremony – Warialda	25 April
	Gravesend Primary School – Long Lunch	27 April
	Farewell Morning Tea – Adam Marshall MP	29 April
Cr Catherine Egan (Deputy Mayor)	ARIC Meeting	22 April
	Naomi Regional Job Precincts – Council Update	22 April
	Farewell Morning Tea – Adam Marshall MP	29 April
	Bingara Central School – Anzac Day Service	30 April
Cr David Coulton	Minister for Emergency Services – Forum & Meeting – Bingara Fire Station	2 April
	Budget Workshop – Warialda	11 April
	BROC Meeting Stanthorpe	12 April
	Working Bee – Warialda Showgrounds	13 April
	Historical Society Meeting – Warialda Museum	16 April

	Ordinary Council Meeting - Warialda	18 April
	Anzac Day Ceremony – Warialda	25 April
	Farewell Morning Tea – Adam Marshall MP	29 April
	Service Level Agreement Committee and Senior Management Team Meeting – Moree Fire Control Centre.	30 April
Cr Geoff Smith	Budget Workshop – Warialda	11 April
	Ordinary Council Meeting - Warialda	18 April
	Anzac Day Ceremony – Warialda	25 April
	Farewell Morning Tea – Adam Marshall MP	29 April
Cr Lyndon Mulligan	Budget Workshop – Warialda	11 April
	Ordinary Council Meeting - Warialda	18 April
	Anzac Day Ceremonies – North Star & Croppa Creek	25 April
Cr Marilyn Dixon	Budget Workshop - Warialda	11 April
	Ordinary Council Meeting - Warialda	18 April
	Anzac Day Ceremony – RSL Bingara	25 April
	Farewell Morning Tea – Adam Marshall MP	29 April
Cr Jim Moore	Budget Workshop – Warialda	11 April
	Ordinary Council Meeting - Warialda	18 April
	Anzac Day Ceremony - Warialda	25 April
	Farewell Morning Tea – Adam Marshall MP	29 April
Cr (Dr) Chris Matthews	Budget Workshop - Warialda	11 April
	Ordinary Council Meeting - Warialda	18 April
Cr Tiffany Galvin	Budget Workshop - Warialda	11 April

OFFICER RECOMMENDATION

THAT the report be received.

ATTACHMENTS

1. March Calendar [9.2.1 - 1 page]
2. April Calendar [9.2.2 - 1 page]

COUNCIL RESOLUTION:

THAT the report be received.

































































(Moved Cr Galvin, Seconded Cr Moore)

CARRIED

For: Cr J Coulton, Cr Egan, Cr D Coulton, Cr Galvin, Cr Matthews, Cr Moore, Cr Mulligan and Cr Smith

Against: Nil

2024 . MARCH

SUN	MON	TUE	WED	THU	FRI	SAT
					1	2
3  QUANTUM LEAP SUBTLE ENERGY 	4  QUANTUM LEAP SUBTLE ENERGY  MEETING X2 	5  QUANTUM LEAP SUBTLE ENERGY  MEETING 	6  QUANTUM LEAP SUBTLE ENERGY 	7  QUANTUM LEAP SUBTLE ENERGY 	8  POETRY & PANCAKES  QUANTUM LEAP SUBTLE ENERGY 	9  POETRY & PANCAKES  QUANTUM LEAP SUBTLE ENERGY 
10  POETRY & PANCAKES  QUANTUM LEAP SUBTLE ENERGY 	11  QUANTUM LEAP SUBTLE ENERGY  MEETING X3 	12  QUANTUM LEAP SUBTLE ENERGY  THEATRE TOUR  MEETING 	13  QUANTUM LEAP SUBTLE ENERGY  THEATRE TOUR  MEETING X2 	14  QUANTUM LEAP SUBTLE ENERGY 	15  THEATRE TOUR	16
17	18  TRAINING	19  MEETING X2	20  MEETING X2	21  QUILTERS RETREAT  QUILTERS RETREAT  MEETING	22  QUILTERS RETREAT  QUILTERS RETREAT	23  QUILTERS RETREAT  QUILTERS RETREAT
24  QUILTERS RETREAT  QUILTERS RETREAT  FILM CLUB	25  MEETING	26  WORKSHOP  MEETING	27  THEATRE TOUR	28  BIRTHDAY PARTY  BIRTHDAY PARTY  BUZZCARE CLEANING  MEETING	29  BIRTHDAY PARTY  BIRTHDAY PARTY  BUZZCARE CLEANING	30  BIRTHDAY PARTY  BIRTHDAY PARTY  BUZZCARE CLEANING
31  BIRTHDAY PARTY  BIRTHDAY PARTY  BUZZCARE CLEANING						

Legend: Roxy: Theatre - Kitchen - conference room

TLC: Classroom - Bunkhouse



2024 . APRIL

SUN	MON	TUE	WED	THU	FRI	SAT
	1 BIRTHDAY PARTY BIRTHDAY PARTY BUZZCARE CLEANING	2 MEETING X4 BUZZCARE CLEANING ROXY TOUR 12X PPL	3 MEETING CONFERENCE MEETING	4	5 SQNNSW HUB	6 PRIVATE FUNCTION PRIVATE FUNCTION
7 PRIVATE FUNCTION	8 MEETING X2 MEETING	9 MEETING ROXY TOUR 2X PPL	10 ARMCHAIR TRAVEL PRIVATE BOOKING MEETING X2	11	12 MEETING ROXY TOUR 2X PPL	13
14	15	16 CATHOLIC SCHOOLS MEETING ROXY TOUR	17 CATHOLIC SCHOOLS MEETING ROXY TOUR	18	19 MEETING ROXY TOUR	20
21 PRIVATE BOOKING	22 MEETING	23 ROXY TOUR 5X PPL	24	25 QUILTERS RETREAT QUILTERS RETREAT	26 QUILTERS RETREAT QUILTERS RETREAT MEETING PRODUCTION PRODUCTION ROXY TOUR	27 QUILTERS RETREAT QUILTERS RETREAT PRODUCTION PRODUCTION
28 QUILTERS RETREAT QUILTERS RETREAT	29 MEETING MEETING	30 LANDCARE MEETING				

Legend: Roxy: Theatre - Kitchen - conference room

TLC: Classroom - Bunkhouse



9.3 DA 29/2023 / PAN-341806

File Reference: DA 29/2023

Delivery Program

Goal: 3. An environmentally responsible shire

Outcome: 3.1 Our community understands and embraces environmental change

Strategy: 3.1.1 Encourage respectful planning, balanced growth and good design

Author: Planning Officer

STAFF DISCLOSURE OF INTEREST

Assessment undertaken by a Council Employee

IN BRIEF/SUMMARY RECOMMENDATION

This application is for the continued use of two existing premanufactured accommodation units, each fully contained with 3-bedrooms, a single bath and an attached double carport linking the two units together, both cabins are to be used as accommodation for professional persons that come to live and work within the Gwydir community on a short to medium-term basis. The units are to be connected to mains water, sewerage, and electricity.

This application is recommended for approval with the inclusion of the draft conditions enclosed at Attachment 1 of this report.

TABLED ITEMS Nil

BACKGROUND

1. The Proposal

Each of two existing premanufactured accommodation units can accommodate up to 6 persons each and will be used to provide medium-short term accommodation for professional person that need to live and work in the Gwydir Shire eg. visiting medical services, Student Doctors.

The accommodation units were constructed at Uniplan's purpose-built manufacturing facility in Armidale, NSW 2350 and were delivered to site in early in June 2023 (between 3 & 6 June 2023). They have been issued with the urban addresses of 2/34 and 3/34 Plunkett Street, Warialda.

According to the proponent, all works were in accordance with the requirements of the Local Government (Manufactured Home Estates, Caravan Parks, Camping Grounds and Moveable Dwellings) Regulation 2021. Certification is to be provided to the client on completion of the works confirming compliance. A Compliance Plate is

to be permanently fixed to each of the accommodation units in accordance with the regulations.

The accommodation units are located wholly within the Lot 1 DP 158301 and are accessed via the existing access road located on Lot C DP 35870, Lot 2 DP 1159943 and Lot 43 DP 1159942 that services the existing Aged Care Units located at 40 Plunkett Street Warialda. The location of the accommodation units is shown on Figures 1, 2 & 3 below. The site was previously clear of vegetation under DA (Development Application) 9/2023, also under which an underground fuel storage tank was also removed from the site. Reason for above conditions: To ensure maintenance of the existing amenity of the area and to reduce or prevent any negative social impacts of the development. The proponent states that validation results show that the tank had not contaminated the surrounding soil.

The first phase (approved under DA 9/2023) of the property included the demolition of three sheds. The removal/decommissioning of three underground fuel tanks. The installation of a three bedroom, two bath premanufacture dwelling and the installation of a two-bedroom, single bath premanufacture dwelling on Lot 19, section 60, in DP 759052. These are being used for emergence accommodation and for respite care services. The first phase of the development also includes the construction of attached carports to each of the accommodation units, internal driveways and the renovation of the retained shop building known as the Bradburn Building.

The second phase of the property includes the installation of two three-bedroom, single bath accommodation units with central double carport and the construction of a new access/egress driveway that connects to the existing internal driveway for the neighbouring Aged Care Units located at 40 Plunkett Street Warialda. It is the continued use of this phase of the development that is subject to this assessment report and subsequent determination.

The setbacks for each of the accommodation units from the boundaries of Lot 1 DP 158301 are as follows:

Accommodation Unit	North	South	West	East
2-34 Plunkett Street	1m	43m	22.6m	1.7m
3-34 Plunkett Street	1m	43m	1m	23.6m

Additionally, the closest part of the development is approximately 41.9m west of Plunkett Street. There is an approximate distance of 21.5m between Units 1/34 & 2/34 Plunkett Street and 8.5m between Units 2/34 & 4/34 Plunkett Street Warialda. The development has one under covered car space per accommodation unit (being the double carport connecting the two accommodation units together and no other designated parking spaces).



Figure 1 – Site Layout

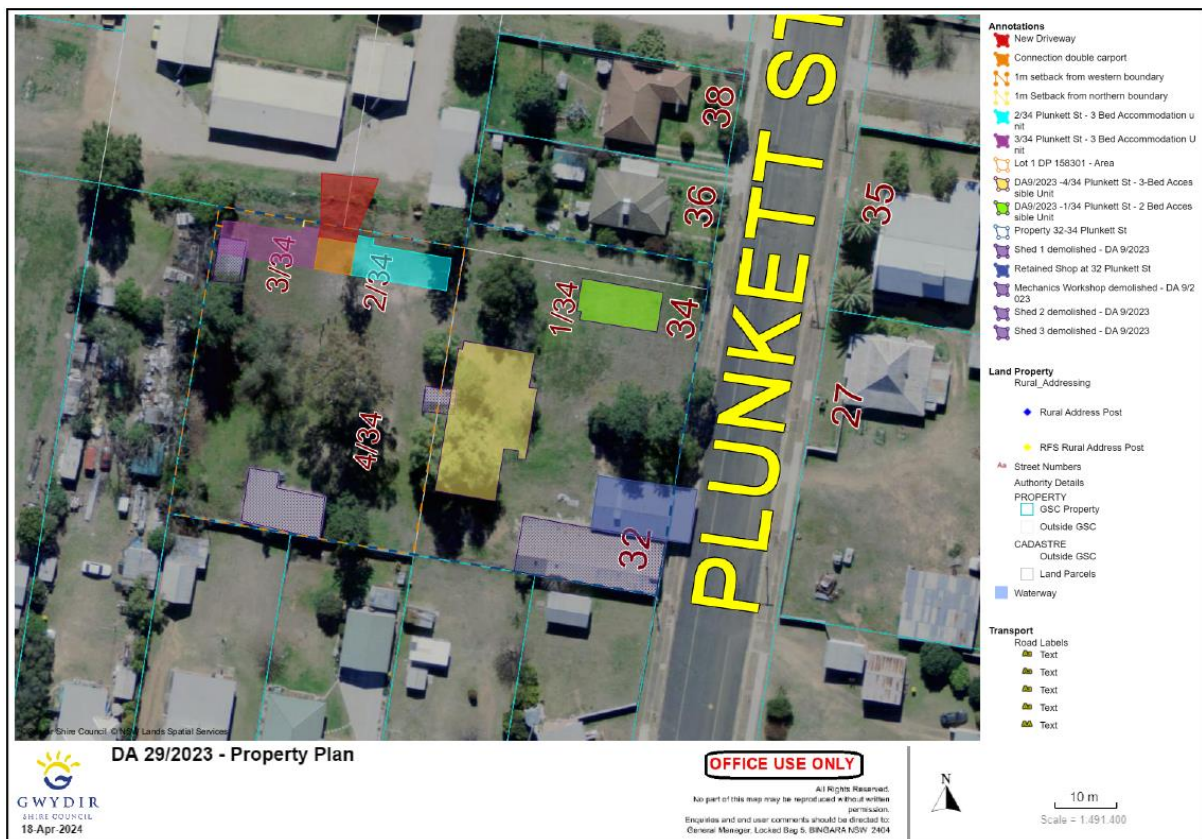

Figure 2 – Property Layout

2. Site Considerations

The site is located on the southwestern part of the Warialda village approximately 2 blocks west of Stephen Street and half a block south of Hope Street, these two streets being the mains streets of Warialda. The property consists of three allotments [being Lot 19 Section 60 DP 759052 (area 1992.6m²), Lot 1 DP 158301 (area 2023m²) & Lot 1 DP 1087650 (area 183.4m²)] and has a total area of 4199m². The property is currently the location of a shop (known as the Bradburn Building), a free-standing three-bedroom, two bath accessible emergency accommodation and respite care unit with attached carport, a free-standing two-bedroom, one bath accessible emergency accommodation and respite care unit with attached carport, the two 3-bedroom, one bath professional accommodation units connected by a double carport. One UFS was located in an open lawned area, approximately halfway along the northern boundary of Lot 1 DP 158301 and was marked by a hand pump protruding overground and a fill point located close by. This UFS was removed to allow for the footings of two three-bed accommodation units.

The development site is bound by six residential allotments all occupied by single dwelling house to the south, west and north. To the northwest an independent seniors living facility is located consisting of 5 detached buildings. The eastern property boundary is directly adjacent to Plunkett Street. The land has no discernible slope, with all stormwaters being directed to Plunkett Streets existing kerb and guttering which transfers stormwater south towards the Warialda Creek. An upgrade of the stormwater disposal for the neighbouring aged care units' site has been undertaken and will form the main disposal method of stormwater from this development.

A report from the EPlanning portal does not reveal any site constraints such as flooding, bush fire, or heritage listing. A search on NSW EPA contaminated land register found no existing contamination records for the site. There is currently no visual evidence at the site of contamination however, there were three UFS on the site which had not been used for a period of approximately 30 years. One of these UFS have been decommissioning in-situ, and the other two (one being located under installed accommodation units the subject of this development assessment) were removed. No other site constraints are known.

A review of the Extracts of Title indicates that Lot 1 DP 158301 are owned by Gwydir Shire Council. No easements or restrictions of use are recorded on either title.

3. Statutory Considerations

3.1 Environmental Planning and Assessment Act 1979

- The development requires approval under this act.
- The development is neither designated nor integrated development
- The development is considered to be a use unlawfully commenced in accordance with Section 4.69 of the Environmental Planning and Assessment Act 1979.

Section 4.69 of the EP&A Act 1979 (formerly Section 109A) states:

- (1) *The use of a building, work or land which was unlawfully commenced is not rendered lawful by the occurrence of any subsequent event except –*
 - (a) *The commencement of an environmental planning instrument which permits the use without the necessity for consent under this Act being obtained therefore, or*
 - (b) *The granting of development consent to that use.*
- (2) *The continuation of a use of a building, work or land that was unlawfully commenced is, and is taken always to have been, development of the land within the meaning of and for the proposed of any deemed environmental planning instrument applying, or which at any time applied, to or in respect of the building, work or land.*

This development therefor seeks the granting of consent under Section 4.69(1)(b). Section 4.15 of the EP&A Act 1979 lists the following Matters for Consideration when assessing a development application:

- (1) **Matters for consideration—general** *In determining a development application, a consent authority is to take into consideration such of the following matters as are of relevance to the development the subject of the development application—*
 - (a) *the provisions of—*
 - (i) *any environmental planning instrument, and*
 - (ii) *any proposed instrument that is or has been the subject of public consultation under this Act and that has been notified to the consent authority (unless the Planning Secretary has notified the consent authority that the making of the proposed instrument has been deferred indefinitely or has not been approved), and*
 - (iii) *any development control plan, and*
 - (iiia) *any planning agreement that has been entered into under section 7.4, or any draft planning agreement that a developer has offered to enter into under section 7.4, and*
 - (iv) *the regulations (to the extent that they prescribe matters for the purposes of this paragraph),*
 - (v) *(Repealed)*
 - that apply to the land to which the development application relates,*
 - (b) *the likely impacts of that development, including environmental impacts on both the natural and built environments, and social and economic impacts in the locality,*
 - (c) *the suitability of the site for the development,*
 - (d) *any submissions made in accordance with this Act or the regulations,*
 - (e) *the public interest.*

3.2 Environmental Planning Instruments

3.2.1 State Environmental Planning Policy (Resilience and Hazards) 2021

Chapter 4 of this SEPP refers to the remediation of contaminated land.

See below Section 4.1 for more detail regarding the possible contamination of the site and the remediation works undertaken.

3.2.2 Gwydir Local Environmental Plan 2013

The land is zoned RU5 village (a rural zone) under this LEP. The RU5 zone objective is:

- *To provide for a range of land uses, services and facilities that are associated with a rural village.*

The proposed dwelling is consistent with the above objective.

The proposed development is for short to medium-term rental housing falls under the following definitions for residential accommodation, dual occupancy and attached dual occupancy, which is permitted with consent within the RU5 land use zone.

residential accommodation

means a building or place used predominantly as a place of residence, and includes any of the following—

- (a) *attached dwellings,*
- (b) *boarding houses,*
- (baa) *co-living housing,*
- (c) *dual occupancies,*
- (d) *dwelling houses,*
- (e) *group homes,*
- (f) *hostels,*
- (faa) *(Repealed)*
- (g) *multi dwelling housing,*
- (h) *residential flat buildings,*
- (i) *rural workers' dwellings,*
- (j) *secondary dwellings,*
- (k) *semi-detached dwellings,*
- (l) *seniors housing,*
- (m) *shop top housing,*

but does not include tourist and visitor accommodation or caravan parks.

dual occupancy

means a dual occupancy (attached) or a dual occupancy (detached).

Note—*Dual occupancies are a type of **residential accommodation**—see the definition of that term in this Dictionary.*

dual occupancy (attached)

means 2 dwellings on one lot of land that are attached to each other but does not include a secondary dwelling.

Note—*Dual occupancies (attached) are a type of **dual occupancy**—see the definition of that term in this Dictionary.*

The continued use of the existing accommodation units is consistent with the above definitions.

3.2.3 Town Strategy Plan

Gwydir Shire does not have a DCP (Development Control Plan). There are, however, town strategy plans which include recommendations for the physical future of Bingara and Warialda. Of relevance to this application are the character of a “grid” based town and the type of streets and buildings that have historically contributed to character. In this respect a centre seal road with grassed swales is a common element nor is grassy verges with kerb and guttering but to a lesser extent. There is a fairly strong “weatherboard” vernacular with good articulation amongst the existing dwelling stock and a strong open rural feel. There is a strong theme of housing demand which this development forms part of satisfying. It is considered that this development is consistent with the vision and objectives of the Warialda Community Plan.

3.3 Environmental Planning and Assessment Regulation 2021

Division 2 of the Regulation identifies various mandatory Conditions of Development Consent. These will be addressed below in the section dealing with recommended Conditions of Consent.

4. Likely Impacts of the Development

The cabins will be built with modern building materials and were transported and delivered fully assembled to the site. Each building will be underlain by a gravel pad and built on piers with a height of 700mm. Each building will also have an attached verandah/porch (on piers), steps and be attached to the double carport at ground level.

The buildings will have the following footprints:

- Each three-bedroom cabin (including verandah and steps) has a footprint of approximately 88.5m².
- The connecting carport has a footprint of 31.8m².

All cladding on the cabins consists of Millwood ruff sawn Weathertex in colours like that of the existing emergency accommodation and respite care units known as Unit 1 and Unit 4 and located on Lot 19 Section 60 DP 759052. These colours include the colourbond colour “Southerly” which is a light grey that mimics the neutrality of concrete and “Shale grey” which is a light delicate warm grey. There will be some existing vegetation at the site that will be retained, mainly located around the perimeter of the property which will assist by visually breaking up the view of the new buildings. It is expected that with suitable landscaping on the site the overall visual impact from all other aspects of this development shall diminish. The proposed accommodation units known as Units 2 and 3 are modest in scale and compatible with the vernacular of other accommodation type developments within Warialda and the shire. It is expected that the use of the cabins will result in a modest increase in traffic along Plunkett Street with a possibility of up to 2-3 vehicles accessing the site per day at full capacity.

Each of the accommodation units have been provided with one covered onsite parking space, with additional parking available along the Plunkett.

4.1 Possible contamination impacts due underground fuel tanks

The history of the site includes the sale of fuel from the three separate fuel tanks (See Figure 3 below). The sale of fuel is estimated to have occurred prior to or during the 1980's. The site history may have included a mechanical workshop as well as a sales facility for a range of products.

The site includes several possible contamination locations including:

- A shop/office building constructed with a timber façade with a deteriorating paint cover of suspected lead-based paint/s;
- Below ground fuel tank under the footpath in front of the wooden shop/office building;

- Below ground fuel tank within a corrugated iron shed;
- Below ground fuel tank in the northwest corner of the site with a hand pump above ground.



Figure 3: Location of underground fuel storage tanks

The UPL shown in Figure 3 as “Fuel Tank 3” was located beneath the development site and has been removed. Validation results show that the tank had not contaminated the surrounding soil. No surface contamination was observed.

4.2 Other Impacts

The other likely impacts are overlooking and lighting spill from parking vehicles. These issues are discussed further in the section 5.

No other significant likely environmental impacts have been identified.

4.3 Site Suitability

The site has no discernible slope and the placement of the manufactured cabins on site should be relatively straightforward. An overhead electricity supply is located on poles on the eastern side of Plunkett Street and an existing connection exists from the existing network to the existing shop building at 32 Plunkett Street. Thus, connection of electricity to the proposed development site can be achieved.

This sites prior use/s include a motor vehicle repair business, mechanical spare parts shop, and a carpenter’s workshop. Although, the existence of the three underground fuel storage tanks been established, there are no obvious signs of contamination (e.g. dead grass, stained soil) at the site. A small number of existing mature trees shall be removed to facilitate the proposed development and all vegetation at the site shall be landscaped and controlled.

The site has access to mains water, sewer and stormwater systems which has or will be connected to the cabins. A separate approval shall be obtained from all onsite water, sewer and stormwater drainage works under s68 of the Local Government Act 1993.

Best practice drainage and sediment controls will be implemented whilst the areas ground covers being re-established. The proposed development extends over a relatively small area, and it will not significantly alter drainage patterns of the site or change the ingress/movement of stormwater over the site.

In general, the site appears to be suitable for the proposed development.

5. Exhibition and Submissions

This proposal was on exhibition from 1 September to 14 September 2023. It was exhibited on Council's website and notified to adjoining neighbours. One submission was received. A summary of the submission is provided below in Section 5.1.

5.1 Submissions

The following to issues or concerns were raised in the one received submission:

- Privacy concerns – Request for Council to increase the height of the boundary fence along the southern side of the allotment.
- Concerned about vehicle headlights shining in the rear of dwelling due to vehicles parking in the double carport or a night.

See below predicted view and light spill maps depict the concerns:

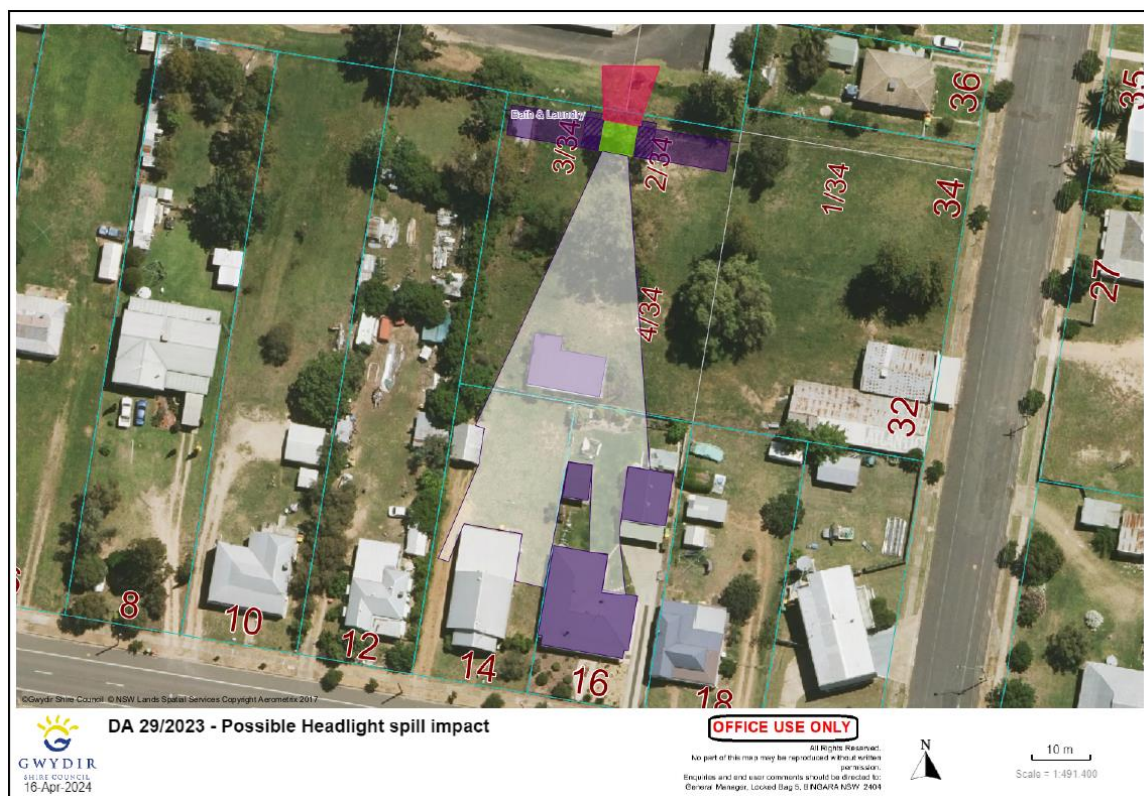

Figure 4: Predicted Light Spill from vehicle headlights accessing double carport.



Figure 5: Possible privacy/view impact from accommodation units

The following photographs of the site also provide a visual representation of the possible light & privacy impacts.



Photograph 1: View taken from in front of Unit 3/34 Plunkett Streets main bedroom window facing south into the rear of 14 Geddes Street, Warialda.



Photograph 2: View taken from in front of connecting double carport facing south into the rear of 14 Geddes Street, Warialda.



Photograph 3: View facing north showing the connecting double carport and the verandahs of both Unit 2 & 3/34 Plunkett Street



Photograph 4: View taken from in front of connecting double carport facing south into the rear of 16 Geddes Street



Photograph 5: View taken from in front of Unit 2/34 Plunkett Streets main bedroom window facing south into the rear of 16 Geddes Street

After an inspection of the site, it is considered that the existing solid fence located along the southern boundary line of the development site, along with the existing buildings and vegetation along the rear of 16 Plunkett Street, provides adequate screening to disperse headlight impacts and provides semi-adequate privacy or overlooking prevention. The one privacy breach observed was from the rear entertaining deck/verandah and kitchen window of 16 Plunkett Street Warialda into the main bedroom window of Unit 2/34 Plunkett Street's and vice versa. This view is shown in Photograph 5 above.

However, the existing solid fence located along the southern boundary line of the development site fails to provide adequate privacy and headlight spill reduction to the rear of the dwelling located at 14 Plunkett Street Warialda. Both dwellings located at 14 and 16 Plunkett Street Warialda have a slightly more elevated position which has exacerbated the overlooking issues, but oppositely, should reduce the impact of light spill issues.

The submission requests that council extend the height of the southern boundary fence by two or three feet (600 to 900mm) with a lightweight material such as lattice or the like.

There are a number of measures, or combination of measures, which could be used to minimise both the privacy and headlight spill impacts to the rear of each of the dwellings at 14 and 16 Geddes Street Warialda. These measures include but are not limited to the following:

- Increase the height of the existing fence with either a solid or partially permeable panel;
- Install a solid bollard or an adequately dense vegetation screen, approximately 1m high along the southern side of the double carport that will block light from headlights;
- Enclose the southern wall of the carport entirely with a similar screening material to what is located on each of the verandahs;
- Install appropriate privacy screens to all bedroom windows along the southern side of each of the units known as 2/34 & 3/34 Plunkett Street Warialda;
- Include in the landscaping of the development property:

- decorative privacy screens close to the southern fence line in positions that reduce direct viewing and block light spill from vehicles parking in the double carport; and/or
- Small tree plantings along the southern boundary fence line that obscures direct views and disperses light from vehicle headlights (will need to be careful not to impair solar access to the existing dwellings).

It is suggested that a condition accompany any approval that requires the implementation of adequate measures to minimisation or mitigation both the privacy impacts to and from the existing dwellings located at 14 and 16 Geddes Street Warialda as well as lighting spill from vehicles parking in the connecting double carport located between Unit 2 & 3, 34 Plunkett Street, Warialda.

CONCLUSION

It is considered that with no significant adverse impacts, and the net gain of the provision of short to medium term rental accommodation, the public interest would be affected in a positive manner especially with the implementation of privacy and light nuisance minimisation and mitigation measures.

CONSULTATION

This proposal was on exhibition from 1 September to 14 September 2023. It was exhibited on Council's website and notified to adjoining neighbours. One submission was received. A summary of the submission is provided above in Section 5.1.

STATUTORY ENVIRONMENT

There will be no impact on the Statutory Environment due to the determination of this development.

POLICY IMPLICATIONS

There will be no anticipated policy implications due to the determination of this development.

FINANCIAL IMPLICATIONS

As this property on which the development has been undertaken is owned by the Gwydir Shire Council, there may be financial implications associated with the implementation of the conditions of consent and with the ongoing management and maintenance of the accommodation units once completed and occupied.

STRATEGIC IMPLICATIONS

It is assumed that strategically, Council will need to provide for the ongoing operation, management, and maintenance of the accommodation units once complete and occupied

OFFICER RECOMMENDATION

THAT the development application DA 29/2023 (PAN-341806) for the continued use of the two existing 3-bedroom, single bath premanufacture short-medium term accommodation units be approved with the inclusion of the draft conditions and advice found at Attachment 1 of this report.

ATTACHMENTS

1. Attachment 1 - Draft Conditions [9.3.1 - 7 pages]
2. Attachment 2 - Statement of Environmental Effects [9.3.2 - 38 pages]
3. Attachment 3 - Submission [9.3.3 - 2 pages]

COUNCIL RESOLUTION:

THAT the development application DA 29/2023 (PAN-341806) for the continued use of the two existing 3-bedroom, single bath premanufacture short-medium term accommodation units be approved with the inclusion of the draft conditions and advice found at Attachment 1 of this report.

(Moved Cr Smith, Seconded Cr D Coulton)

CARRIED

For: Cr J Coulton, Cr Egan, Cr D Coulton, Cr Galvin, Cr Matthews, Cr Moore, Cr Mulligan and Cr Smith

Against: Nil

Attachment 1 – Draft Conditions

Advising

Please read all conditions carefully. The applicant/developer may arrange to meet with Council to review and clarify, if necessary, the precise requirements of the conditions of this consent. Advice is not part of the condition but helps to explain the condition.

Note: A reference to the Building Code of Australia in this document is to be read as a reference to the National Construction Code which has superseded the BCA.

Please note carefully the following general advice:

1. *It is your responsibility to make sure that:*
 - a. *The site works don't interfere with any services. Use "dial before you dig" to make sure. If services are affected, you will either need to pay to have them relocated, or modify your consent to avoid them.*
 - b. *You connect the dwelling to water and sewer and make the appropriate applications to Council for this to occur.*
 - c. *You connect to the power.*
2. *You don't need to connect a phone line, unless you want to.*

1. General Conditions

1.1 Provide conditions to contractors and subcontractors

A copy of this consent, all endorsed plans and other documents is to be provided to contractors and subcontractors working on the site.

Reason(s) for the above condition(s). To ensure that all people involved in the construction are aware of these conditions.

Advising: *You should supply them with an electronic copy, but make sure there is a hard copy on-site for workers to refer to.*

1.2 Approved plans and supporting documentation

The Development must be carried out in accordance with the following approved plans and supporting documentation (stamped by Council), except where the conditions of this consent expressly require otherwise.

Document Title	Version No.	Prepared by	Dated
----------------	-------------	-------------	-------

Plunkett Street Accommodation Respite Care Statement of Environmental Effects, 32 Plunkett Street Warialda NSW 2402, Lot 1 DP 158301	1	SMK Consultants	June 2023
--	---	-----------------	-----------

Reason(s) for the above condition(s). To make sure it is clear which documents and plans are to be used to construct the development.

Advising

An inconsistency occurs between an approved plan and supporting documentation or between an approved plan and a condition when it is not possible to comply with both at the same time. If these occur, the plans override the supporting documentation, and the conditions override both.

1.3 Compliance with Building Code of Australia and insurance requirements under Home Building Act 1989

- (1) It is a condition of a development consent for development that involves **building work** that the work must be carried out in accordance with the requirements of the Building Code of Australia.
- (2) It is a condition of a development consent for development that involves **residential building work** for which a contract of insurance is required under the Home Building Act 1989, Part 6 that a contract of insurance is in force before building work authorised to be carried out by the consent commences.
- (3) It is a condition of a development consent for a **temporary structure** used as an entertainment venue that the temporary structure must comply with Part B1 and NSW Part H102 in Volume 1 of the Building Code of Australia.
- (4) In subsection (1), a reference to the Building Code of Australia is a reference to the Building Code of Australia as in force on the day on which the application for the construction certificate was made.
- (5) In subsection (3), a reference to the Building Code of Australia is a reference to the Building Code of Australia as in force on the day on which the application for development consent was made.
- (6) This section does not apply—
 - (a) to the extent to which an exemption from a provision of the Building Code of Australia or a fire safety standard is in force under the Environmental Planning and Assessment (Development Certification and Fire Safety) Regulation 2021, or
 - (b) to the erection of a temporary building, other than a temporary structure to which subsection (3) applies.

Reason(s) for the above condition(s). Mandatory conditions under Section 69 of the EP&A Regulation 2021.

1.4 Alterations and Additions to buildings

- a. The verandah on each of the accommodation units known as Unit 2 and Unit 3, 34 Plunkett Street Warialda are not to be further enclosed without prior Council approval.
- b. The connecting carport adjoining and attached to each of the accommodation units known as Unit 2 and Unit 3, 34 Plunkett Street Warialda is not to be further enclosed without prior Council approval.

1.5 Change of Building Use

- a. The use of either or both of the accommodation units known as Unit 2 and Unit 3, 34 Plunkett Street Warialda shall not be altered without the prior approval of Council.
- b. Any change of use/classification in relation to the use of the buildings as mentioned n a. above shall not be made until approval in writing by this Council is first obtained.

1.6 Approval under s68 (A)(1) & (C)(5)(6) of the Local Government Act 1993

Prior to undertaking onsite water, sewer and stormwater drainage works at the site an approval under s68 of the Local Government Act 1993 is to be obtained. A site plan and any other documentation required by the principal certifying authority shall be submitted with the application showing the location the buildings and the site of the system and its disposal area.

Reason for above condition: To ensure the adequate treatment and disposal of sewerage at the site.

Advising

A s68 Application form can be obtained from the Gwydir Shire Councils website www.gwydir.nsw.gov.au

1.7 Contamination Validation Report

The applicant shall provide a validation report to Gwydir Shire Council for removed underground fuel tank that was located along the northern boundary of Lot 1 DP 158301, prior to the issue of an approval to occupy the two three-bedroom premanufactured accommodation units.

Reason for above conditions: To ensure the site is free of contamination and fit for the purpose of residential accommodation and to ensure adequate public health.

1.8 Privacy Impacts

The applicant/developer/owner shall undertake or install adequate measures to prevent or minimisation the direct viewing or overlooking of the bedrooms located along the southern side of each of the accommodation units known as Unit 2 and Unit 3, 34 Plunkett Street Warialda form the rear of the existing dwellings located at 14 and 16 Geddes Street, Warialda or vice versa.

Reason for above conditions: To ensure maintenance of the existing amenity of the area and to reduce or prevent any negative social impacts of the development.

Advising:

There is a number of measures or combination of measures which could be used to minimise privacy impacts. These measures may include but are not limited to the following:

- Increase the height of the existing fence with either a solid or partially permeable panel;
- Install appropriate privacy screens to all bedroom windows;
- Include landscaping that includes:
 - decorative privacy screens positioned to reduce direct viewing or overlooking
 - Plant a small tree border along fence line that obscures direct views.

1.9 Light Spill Impacts

The applicant/developer/owner shall undertake or install adequate measures to prevent or minimisation light from vehicle headlights parking in the double carport located between Unit 2 and Unit 3, 34 Plunkett Street Warialda impacting the rear of either of the existing dwellings located at 14 and 16 Geddes Street, Warialda.

Reason for above conditions: To ensure maintenance of the existing amenity of the area and to reduce or prevent any negative social impacts of the development.

Advising:

There is a number of measures or combination of measures which could be used to minimise privacy impacts. These measures may include but are not limited to the following:

- *Increase the height of the existing fence with either a solid or partially permeable panel;*

- *Install a solid bollard or an adequately dense vegetation screen, located so as to block light from headlights;*
- *Install a wall of lattice or slates like material to carport located so as to block light from headlights entering neighbouring properties;*
- *Include landscaping that includes:*
 - *decorative privacy screens positioned to reduce light shining directly into neighbouring properties,*
 - *Plant a small tree border along fence line that disperses direct light impacts.*

1.10 Erection of signs

- (1) This condition applies to all development involving building work, subdivision work or demolition work.
- (2) It is a condition of this development consent that a sign must be erected in a prominent position on a site on which building work, subdivision work or demolition work is being carried out—
 - (a) showing the name, address and telephone number of the principal certifier for the work, and
 - (b) showing the name of the principal contractor, if any, for the building work and a telephone number on which the principal contractor may be contacted outside working hours, and
 - (c) stating that unauthorised entry to the work site is prohibited.
- (3) The sign must be—
 - (a) maintained while the building work, subdivision work or demolition work is being carried out, and
 - (b) removed when the work has been completed.
- (4) This section does not apply in relation to—
 - (a) building work, subdivision work or demolition work carried out inside an existing building, if the work does not affect the external walls of the building, or
 - (b) Crown building work certified to comply with the Building Code of Australia under the Act, Part 6.

Reason(s) for the above condition(s). Mandatory conditions under Section 70 of the EP&A Regulation 2021.

1.11 Hours of Work

You must ensure that building work, demolition or vegetation removal is only carried out between:

- 7am to 6pm on Monday to Friday AND 8am to 1pm on Saturday
- (No work on Sundays and public holidays)

You must ensure building work, demolition or vegetation removal is not carried out on Sundays and public holidays, except where there is an emergency.

Reason(s) for the above condition(s). To protect the amenity of the surrounding area.

Advising:

Refer <https://www.environment.nsw.gov.au/questions/regulations-for-noisy-construction>

Any variation to the hours of work requires Council's written approval. This can be done by a letter, after writing to Council, if Council agrees. This can go by email.

1.12 Erosion and Sediment Control

Erosion and sediment control measures shall be undertaken during the construction of the dwelling in accordance with the "Blue Book". (Managing Urban Stormwater: Soils and construction - Landcom 2004).

Reason(s) for the above condition(s). To protect against sedimentation of drains and waterways.

Advising:

You only need to use measure that make sense for your site. Council suggests that an Erosion and Sediment Control Plan be developed for review and endorsement by the certifier.

The "Blue Book" can be found at:

<https://www.environment.nsw.gov.au/research-and-publications/publications-search/managing-urban-stormwater-soils-and-construction-volume-1-4th-edition>

1.13 Dust control

Effective dust control measures are to be maintained during construction to maintain public safety/amenity.

Reason(s) for the above condition(s). To protect the amenity of the surrounding area

Advising: *Failure to take effective action may render the developer liable to prosecution under the NSW Protection of the Environment Operations Act. Dust is a problem when it is clearly visible in the area. You can manage dust by watering unsealed access to the site, and also making sure that you only clear what is absolutely necessary for the building to be put on site.*

1.14 Disposal of waste

Materials must not be burned on-site. All waste generated on site must be disposed of at Council's Waste Disposal Depot or a Council Waste Transfer Station.

Reason(s) for the above condition(s). To protect the amenity of the surrounding area and to avoid the potential of air pollution.

2 Before Occupation

2.1 Provision of compliance information

- (1) A certificate is to be issued by a practising structural engineer in accordance with clause 48 of the Local Government (Manufactured Home Estates and Manufactured Homes) Regulation 1995.
- (2) The certifier shall ensure that the manufactured dwelling meets the requirements of sections 49 through 64 of the Local Government (Manufactured Home Estates and Manufactured Homes) Regulation 1995.

Reason(s) for the above condition(s). Required by the Local Government (Manufactured Home Estates and Manufactured Homes) Regulation 1995.

Advising: *This is needed because a construction certificate is not required.*

2.2 Provision of Validation Reports for all sites where contamination or potential contamination remediation works have been undertaken.

Provide Validation report/s (including any future monitoring if necessary) in accordance with the requirements of the Gwydir Shire Council adopted policy and procedures "Managing Contaminated or Potentially Contaminated Land 2019", Contaminated Land Management Act 1997, Contaminated Land Management Regulation 2022 and State Environmental Planning Policy (Resilience and Hazards) 2021 (replaced the SEPP 55).

Reason for above conditions: To ensure compliant completion of all remediation works to the required standards set down in the Gwydir Shire Councils adopted policy and procedures "Managing Contaminated or Potentially Contaminated Land 2019", Contaminated Land Management Act 1997, Contaminated Land Management Regulation 2022 and State Environmental Planning Policy (Resilience and Hazards) 2021 (replaced the SEPP 55) and to ensure that the approved use of the land is fit for purpose and provides, without compromise, a safe and healthy environment.

SMK

CONSULTANTS

surveying – irrigation – environmental – planning
ABN 63 061 919 003

39 Frome Street
PO Box 774
Moree NSW 2400
Ph 02 6752 1021
Fax 02 6752 5070
admin@smk.com.au

www.smk.com.au

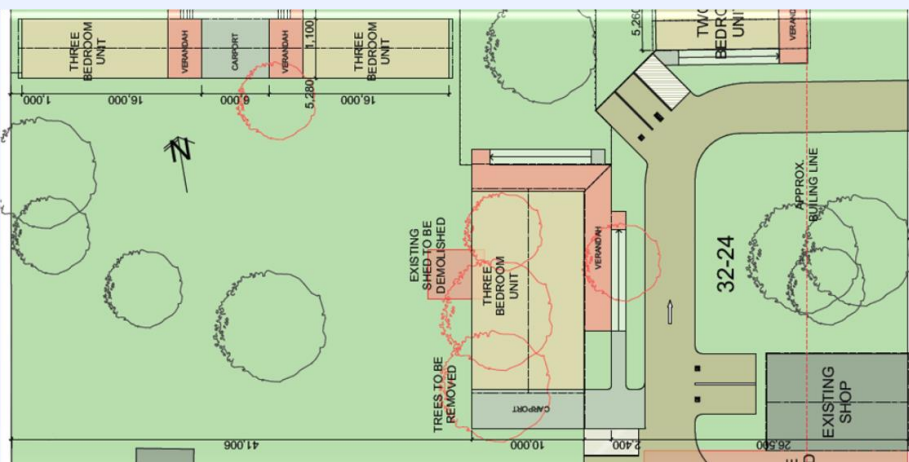

Plunkett Street Accommodation Respite Centre

STATEMENT OF ENVIRONMENTAL EFFECTS

32 Plunkett Street Warialda NSW 2402
Lot 1 DP158301

June 2023

SMK Consultants Pty Ltd has prepared this document.

Copyright 2023 by SMK Consultants Pty Ltd.

All rights reserved, no part of this publication may be reproduced, stored in a retrieval system or transmitted, in any form or by any means, electronic, mechanical, photocopying, recording, or otherwise, without prior written permission.

All images and diagrams remain the property of SMK Consultants Pty Ltd.

SMK
CONSULTANTS

surveying – irrigation – environmental – planning

ABN 63 061 919 003

SMK

CONSULTANTS

surveying – irrigation – environmental - planning
ABN 63 061 919 003

39 Frome Street
PO Box 774
Moree NSW 2400
Ph 02 6752 1021
Fax 02 6752 5070
admin@smk.com.au
www.smk.com.au

Accommodation and Respite Centre

STATEMENT OF ENVIRONMENTAL EFFECTS

32 Plunkett Street Warialda NSW 2402.

Lot 1 DP158301

Prepared by: **SMK Consultants**
39 Frome Street, Moree, NSW 2400

June 2023

iii

DOCUMENT CONTROL

Project Name	Warialda Respite Centre
Proponent	Gwydir Shire Council Locked Bag 5 Bingara NSW 2404
Project Reference	22-408-B
Report Number	22-408-Statement of Environmental Effects
Prepared for	Gwydir Shire Council Locked Bag 5, Bingara, NSW 2404 Ph: 02 6724 2000 Email: csouthwell@gwydir.nsw.gov.au
Prepared by	SMK Consultants 39 Frome Street Moree, NSW 2400
Contact	Bruno Nwokolo Ph: (02) 6752 1021 E: Bruno@smk.com.au

<i>Author</i>	
Name	<i>Biyomi Palkadapela</i> Biyomi Palkadapela
Position	Environmental Consultant
Company	SMK Consultants

<i>Reviewed By</i>	
Name	<i>Peter Taylor</i> Peter Taylor <small>BSc MEIANZ CIAg LAA</small>
Position	Environment & Resource Consultant
Company	SMK Consultants

Revision History			
Version Number	Date	Authority	Details
0	June 2023	P. Taylor	Final submitted to Portal
1	June 2023	P. Taylor	Conflict of Interest Policy added

EXECUTIVE SUMMARY

This Statement of Environmental Effects (SoEE) has been prepared by SMK Consultants on behalf of Gwydir Shire Council to support the development of an emergency accommodation and respite centre at 32 Plunkett Street in Warialda. The centre will offer emergency accommodation for emergency services and respite care for people within the region.

Applicant:	Gwydir Shire Council 2 Geddes Street Warialda NSW 2402
Owner:	Gwydir Shire Council
Subject Land:	Lot 1 in Deposited Plan 158301 32 Plunkett Street Warialda NSW 2402.
Zoning:	RU5 – Village under the Gwydir LEP 2013
Local Government Authority:	Gwydir Shire Council
Proposed Development:	Construction of two by three bedroom units for Emergency Accommodation and Respite services on Lot 1 in DP158301 (Western side of 32 Plunkett Street)
Type of Development:	Local Development under the <i>Gwydir Local Environmental Plan 2013</i>
Permissibility:	The proposed development is permissible with the consent of the Gwydir Shire Council.

Approvals and Licences

The construction of the proposed accommodation building requires Development Consent from Gwydir Shire Council under Part 4 of the *Environmental Planning and Assessment Act 1979*. Council consent for the development is required. No other approvals or licences are considered necessary.

TABLE OF CONTENTS

1	Introduction	8
1.1	Proponent Details	8
1.2	Authors and Guidelines.....	8
1.3	Locality	8
2	Proposed Development	11
2.1	Proposal Outline	11
3	Policy and Legislation Assessment.....	15
3.1	Permissibility.....	15
3.2	Commonwealth Legislation and Regulations	15
3.2.1	Environmental Protection and Biodiversity Conservation Act 1999	15
3.3	State Legislation, Regulations and Policies.....	16
3.3.1	Environmental Planning and Assessment Act 1979	16
3.3.2	Environmental Planning and Assessment Regulation 2000	16
3.3.3	Biodiversity Conservation Act 2016.....	16
3.3.4	State Environmental Planning Policies	17
3.4	Local Planning Instruments.....	19
3.4.1	Gwydir Local Environmental Plan 2013	19
3.4.2	Heritage Conservation	20
3.4.3	Conflicts of Interest Policy	20
3.4.4	Bushfire Hazard.....	21
3.4.5	Earthworks	21
3.4.6	Draft Environmental Planning Instruments.....	22
3.4.7	Development Contribution Plan	22
3.4.8	Development Control Plans	22
4	Environmental Assessment.....	22
4.1	Location.....	23
4.2	Land Contamination.....	23
4.3	Air Quality	24
4.4	Water Resources.....	24
4.5	Noise Impacts.....	25
4.5.1	Construction Noise.....	25

4.5.2	Operational Noise	28
4.6	Waste	28
4.7	Natural Hazards	29
4.7.1	Bushfire Risk.....	29
4.7.2	Flooding and Stormwater	29
4.8	Cultural Heritage.....	29
4.8.1	Indigenous Heritage.....	29
4.8.2	Non-indigenous Heritage.....	30
4.9	Flora and Fauna.....	30
4.10	Visual Impacts	30
4.11	Access, Traffic and Parking	31
4.12	Services and Utilities.....	31
4.13	Social and Economic Impacts.....	31
4.14	Cumulative Impacts	32
5	Conclusion and Recommendations	32
	Appendix 1- Building Plan for the two by three-bedroom unit.....	33
	Appendix 2 – AHIMS Search (Aboriginal Heritage Information Management System)	38
FIGURES		
	Figure 1: Locality plan for proposed two by three bedroom units.....	9
	Figure 2: Locality Plan of proposed Respite and Emergency Accommodation facility	10
	Figure 3: Overall site plan showing approved and proposed Units.....	13
	Figure 4: Site photo looking west toward the location of the additional accommodation building site.....	14
	Figure 5: Looking toward Plunkett Street from west side of Lot.....	14
	Figure 6: Fuel tank was located in northwest sector of Respite Centre facility.	19

1 Introduction

SMK Consultants has been engaged by Gwydir Shire Council to prepare this Statement of Environmental Effects (SoEE). This report will accompany a Development Application (DA) to be submitted to Gwydir Shire Council. The application seeks consent for the construction of two by three bedroom units for Emergency Accommodation facility and Respite Centre on Lot 1 DP158301.

1.1 Proponent Details

The property consists of one Lot, mainly Lot 1 in Deposited Plan 158301. The land is owned by the Gwydir Shire Council.

Table 1: Proponent Details

Proponent	Gwydir Shire Council
Contact Name	Carmen Southwell – Community Assets Manager
Address	Locked Bag 5 Bingara NSW 2404
Email	csouthwell@gwydir.nsw.gov.au

1.2 Authors and Guidelines

Persons involved in the preparation of this Statement of Environmental and its appendices are:

- **Biyomi Palkadapela**
- **Peter Taylor** B.Sc. MEIANZ CIAg LAA

1.3 Locality

The site is situated in Plunkett Street in the central part of the southern residential and commercial sector of Warialda. The property is surrounded by residential housing, with Hope Street to the north of the property, Holden Street to the west, and Geddes Street to the south. Access to the property is from Plunkett Street to the east of the development site.

The adjoining development to the north on Lots 2 DP1159943 and Lot 43 DP1159942 is occupied by an aged care unit development owned by Council.

The real property description is Lot 1 in Deposited Plan (DP) 158301. The development site is zoned RU5: Village under the Gwydir Local Environmental Plan 2013 (LEP) and comprises an area of approximately 550m².

The existing approved development on this site includes free standing buildings and a carparking area. The approved buildings consist of a two bedroom and a three-bedroom unit to be used for accommodation of emergency workers as well as a respite centre when no emergency workers need accommodation.

The addition of two by three-bedroom units on the western side of 32 Plunkett Street will provide additional accommodation and respite services for the same purpose as the approved development.

Figure 1 and 2 shows the location of the development site within Warialda.

Figure 1: Locality plan for proposed two by three bedroom units.

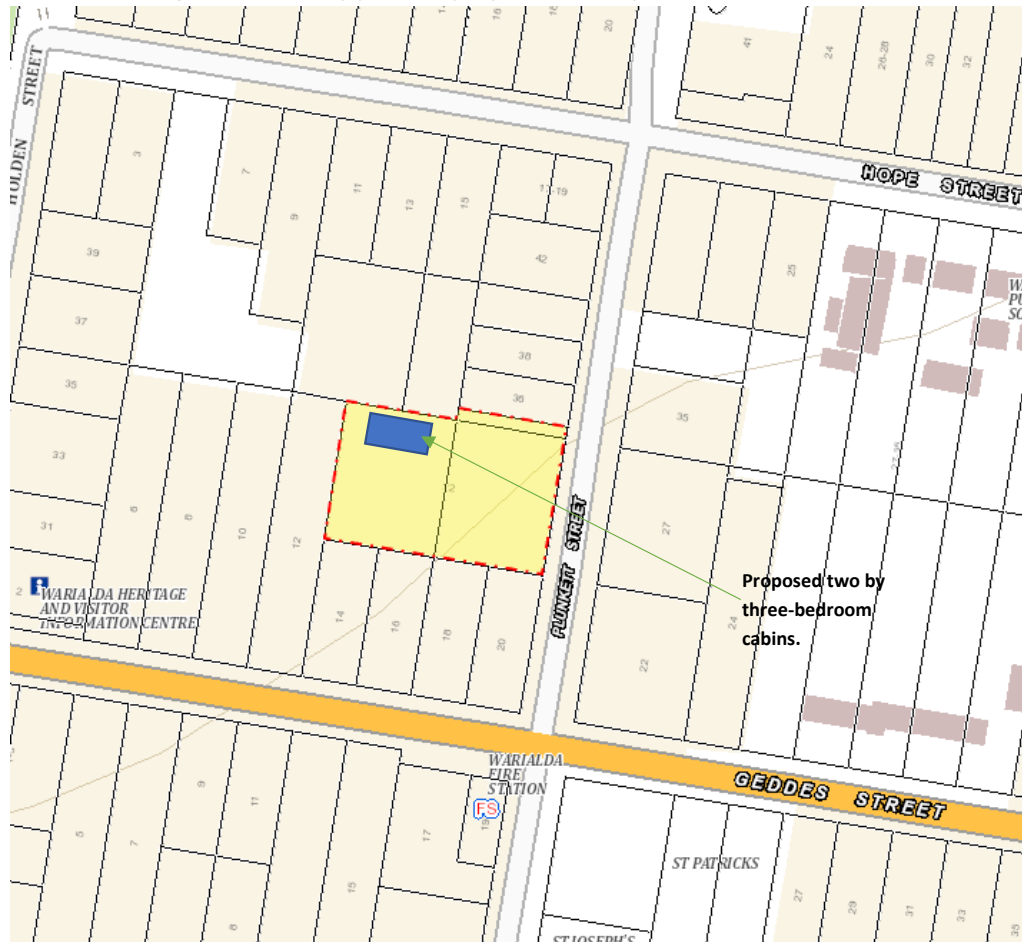

Figure 2: Locality Plan of proposed Respite and Emergency Accommodation facility



2 Proposed Development

2.1 Proposal Outline

The proponent intends to install two prefabricated modular units of three bedrooms as two separate buildings and link the two buildings with a covered carpark in the centre. The 3-bedroom units will have an open kitchen-lounge area with shared bathroom and laundry facilities.

The structure includes verandahs attached to the buildings which adjoin the central carpark.

The front of the proposed building will face north toward the existing aged care Units and primary vehicle access. The intended building will be installed on the western part of 32 Plunkett Street.

The buildings will be accessible via the Laneway located on Lot C DP35870. This Laneway provides vehicle access to the adjoining aged care units. Pedestrian access will be available directly across Lot 19 section 60 DP759052 where the approved units are to be built.

The building is to be placed on concrete foundations and tied to the foundation by a system of chains. The building will be connected into the Warialda sewer and water system. Storm drainage will be similar to the aged care units to the north in that it will drain north toward Warialda Creek via a system of below ground pipes and open drains.

The new buildings will be constructed by the same manufacturer as the existing approved buildings. They will be made of the same materials and have the same colour scheme to match the approved buildings.

The main objective of the proposal is to provide additional emergency accommodation facility for local residents and emergency service personal during disaster events such as a bush fire or flood where parts of Warialda may be evacuated, and the one local Motel is full of people.

During the period of non-disaster in this area the units are not required for natural disaster accommodation, it will be available for respite services for local residents with disabilities, and possibly aged care service providers for respite services to aged people in the locality. There is little or no respite care facilities in Warialda at present.

Council is building the units under a grant from the \$2.2 Billion National Bushfire Recovery Fund program which aims to support communities affected by bushfire in addition to planning ahead for future fires. The proposed project would have a lasting benefit for the local community, supporting the wellbeing of families, while temporarily housing people affected by natural disaster.

Plans of the building are presented in Appendix 1. The plans include a site layout showing the buildings which have been approved under DA 9/2023 and the new building on the western side of the property.

The additional accommodation building will not alter the development proposed under the existing approval. The project approved will involve preservation of the original shop on the site and the demolition of the adjoining corrugated iron storage shed on the south of the original shop. The demolition work has been completed under DA 9/2023.

The open lawn around the proposed accommodation building will be preserved for the purpose of providing a playground area for children who attend the site for respite and care purposes. Some of these areas are within the cleared mown area shown in the figure 4. Some trees that are within the proposed building location will be removed prior to commencement of the development.

A small below ground fuel tank and hand pump was located beneath the location of the additional accommodation building. This has been removed and subjected to remediation. At present, a Validation report is being prepared for the fuel tank removal work. The results of soil testing indicate that no fuel contamination was present. This validation report will be submitted under DA 9/2023.

The overall site plan for the three buildings is presented below in figure 3.

The option to develop a bitumen sealed car park area at strategic location within the site remains under consideration. Photographs presented below show the site prior to installation of the two eastern buildings. The old shop is located on Plunkett Street. The land supports a good grass cover and a few trees. The trees have been lopped as part of DA 9/2023 for safety and other old disused structures within the property have now been removed.

22-408B Warialda Respite Centre

Statement of Environmental Effects

Figure 3: Overall site plan showing approved and proposed Units.

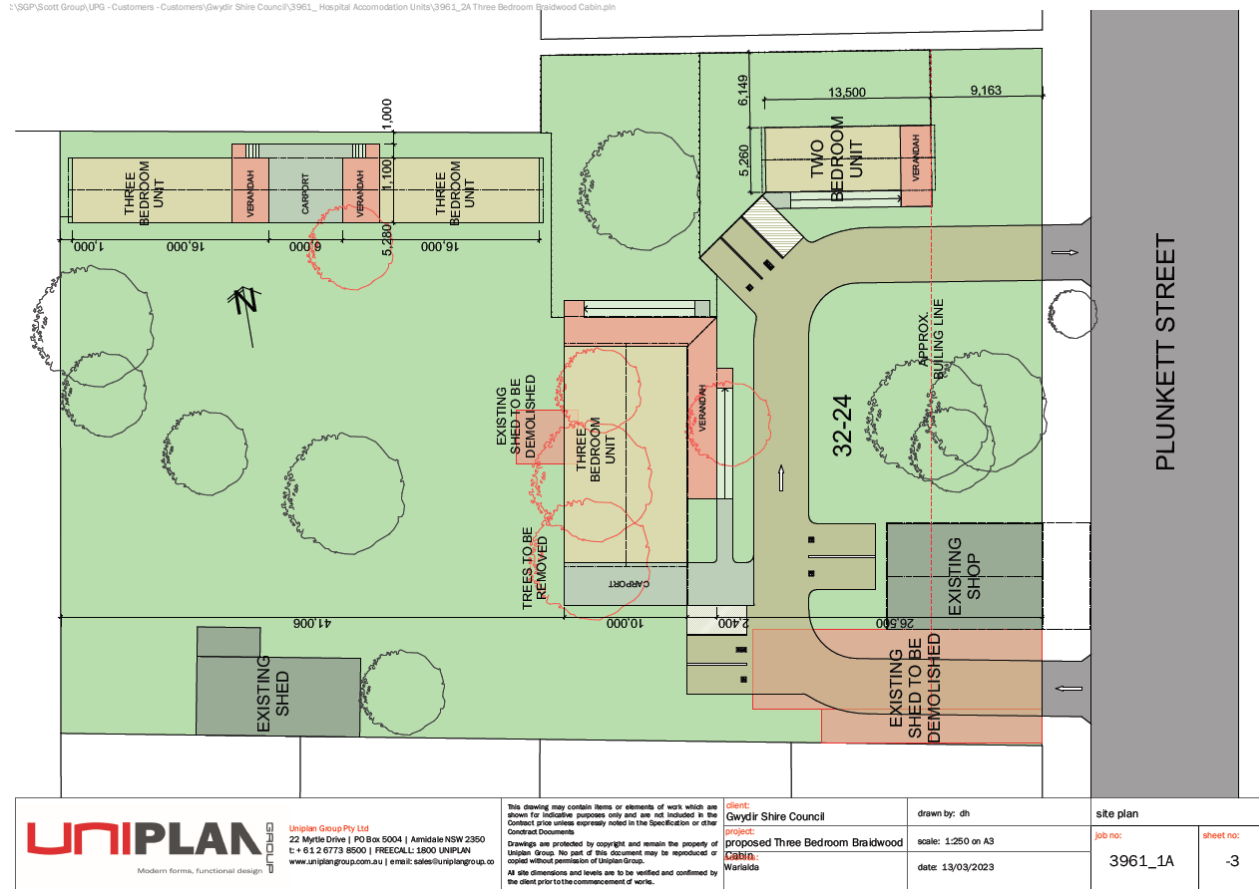

Figure 4: Site photo looking west toward the location of the additional accommodation building site.



Figure 5: Looking toward Plunkett Street from west side of Lot.



3 Policy and Legislation Assessment

3.1 Permissibility

The development proposal is considered Local Development under Part 4 of the *Environmental Planning and Assessment Act, 1979*. The proposal therefore requires development consent from the Gwydir Shire Council as the determining authority.

The proposed development is considered compatible with the objectives of the site's RU5 – Village, and permissible, with development consent, under the provisions of the *Gwydir Local Environmental Plan 2013* (LEP). Concurrence is not required from any other authority before the development may lawfully be carried out.

3.2 Commonwealth Legislation and Regulations

3.2.1 Environmental Protection and Biodiversity Conservation Act 1999

The *Environment Protection and Biodiversity Conservation Act 1999* (the EPBC Act) is the Australian Government's central piece of environmental legislation. It provides a legal framework to protect and manage nationally and internationally important flora, fauna, ecological communities, and heritage places defined in the EPBC Act as Matters of National Environmental Significance (MNES). The EPBC Act provides guidelines for an assessment process to determine whether a development needs referral to the Federal Department of Environment, Water, Heritage, and the Arts (DEWHA) in Canberra.

If a development requires referral the commonwealth minister, for the Environment for actions on Commonwealth land, will grant approval based on the potential for the development to have a significant impact on matters of national environmental significance, which include:

- World Heritage Properties;
- Ramsar Wetlands;
- Nationally threatened species and communities;
- Migratory species protected under international agreements;
- The commonwealth marine environment; and
- Nuclear actions.

The proposed development is considered in accordance with the EPBC Act. The proposal is not considered to have the potential as a significant impact on any MNES. Hence, this proposal is consistent with the objectives of the EPBC Act.

3.3 State Legislation, Regulations and Policies

3.3.1 Environmental Planning and Assessment Act 1979

The *Environmental Planning and Assessment Act 1979* provides the framework for NSW Planning Legislation. Under this Act, local Councils prepare Local Environmental Plans (LEPs) that specify planning controls for specific parcels of land. The Act also provides for State Environmental Planning Policies (SEPPs) and Regional Environmental Plans (REPs). Applicable SEPPs are discussed in Section 2.2.4.

This document has been prepared in accordance with the requirements of this Act. The following sections address matters for consideration outlined under Section 79C (1) of the Act to provide an assessment of how the development complies with relevant legislation and policies, and how the proposal will be developed and managed to protect the built and natural environment.

3.3.2 Environmental Planning and Assessment Regulation 2000

The NSW *Environmental Planning and Assessment Regulation 2000* requires that certain documents must accompany a development application. This Statement of Environmental Effects and its attachments satisfy these requirements.

3.3.3 Biodiversity Conservation Act 2016

The BC Act outlines requirements in relation to the listing of threatened species, biodiversity impact assessment, offsetting, and related offences. The assessment of biodiversity values on land and the impacts of activities on those biodiversity values are to be carried out in accordance with the Biodiversity Assessment Method (BAM). The objective of the BAM is to adopt a standard approach that will result in no net loss of biodiversity in NSW.

The Act also outlines the Biodiversity Offset Scheme (BOS). Development that is subject to the BOS scheme includes development needing consent under Part 4 of the EP&A Act (excluding complying development).

Where development or an activity is, “likely to significantly affect threatened species”, a Biodiversity Development Assessment Report (BDAR) must be prepared, and consent authorities are required to consider the likely impact of the proposed development on biodiversity values before granting approval.

Section 7.2. of the BC Act states that an activity is “likely to significantly affect threatened species” (and therefore whether a BDAR is required) is reached if:

- The test in section 7.3 of the BC Act identifies matters that may significantly impact threatened species, populations or endangered communities;
- The Biodiversity Offset Scheme (BOS) Threshold is exceeded; and

- The development is carried out in a declared area of outstanding biodiversity value.

The subject land was assessed using the online Biodiversity Offsets Scheme Entry Tool, which determines whether any proposed clearing of native vegetation would be above or below the area thresholds or lies within an area mapped as having high biodiversity value. According to BOS, the native vegetation clearing threshold is 0.25 Ha.

The proposed accommodation facility is located on cleared developed land which has a mown lawn and a range of non-native vegetation. Vegetation onsite is not deemed to exceed the 50-percent native vegetation criteria and therefore the vegetation onsite is not deemed to be considered as native. Construction of the units would therefore not require any native vegetation clearance and the BOS clearing threshold would not be exceeded.

The proposed development site is not located in an area of outstanding biodiversity value.

Given that the proposal is located on existing developed land devoid of native vegetation, a ‘Test of Significance’ in accordance with Section 7.3 of the BC Act was not considered necessary, as it is clear that the development would not have a significant impact upon protected flora, fauna, populations and communities that may be present in the locality. The development is therefore considered permissible under the provisions of the BC Act.

3.3.4 State Environmental Planning Policies

The following table presents a summary and comment on current State Environmental Planning Policies and identifies their relevance to the proposed development.

Table 2: State Environmental Planning Policies and Development Codes

SEPP Title	Relevance
State Environmental Planning Policy (Planning Systems) 2021	Not Relevant
State Environmental Planning Policy (Biodiversity and Conservation) 2021	Koala – No Habitat Present
State Environmental Planning Policy (Resilience and Hazards) 2021	Review provided below
State Environmental Planning Policy (Transport and Infrastructure) 2021	Review provided below
State Environmental Planning Policy (Industry and Employment) 2021	Not Relevant
State Environmental Planning Policy (Resources and Energy) 2021	Not Relevant
State Environmental Planning Policy (Primary Production) 2021	Not Relevant

SEPP Title	Relevance
State Environmental Planning Policy (Precincts – Eastern Harbour City) 2021	Not Relevant
State Environmental Planning Policy (Precincts – Central River City) 2021	Not Relevant
State Environmental Planning Policy (Precincts – Western Parkland City) 2021	Not Relevant
State Environmental Planning Policy (Precincts – Regional) 2021	Not Relevant

3.3.4.1 State Environmental Planning Policy (Resilience and Hazards) 2021

Chapter 4 of the *Resilience and Hazards SEPP 2021* covers remediation of land and aims to promote the remediation of contaminated land for the purpose of reducing the risk of harm to human health or other aspects of the environment. Where it is proposed to rezone the land or to carry out a development that would change the use of the land a consent authority must consider whether the land is contaminated and if it is, whether the land is suitable for the proposed development in its present state or whether remediation is required. Even where no change of use is proposed a consent authority must consider whether the land is suitable for the proposed development if the land has been used for a purpose listed in Table 1 of Appendix 1 in Contaminated Land Planning Guidelines (NSW Government, 2018 (Draft)).

Based on a review of aerial imagery of the site, the subject site and its surrounds consist of residential buildings. The development site was once used as a point of sale for fuel products that included below ground fuel tanks. The primary concern of this site relates to the presence of at least three below ground fuel tanks and related fuel pipes.

A search on NSW EPA contaminated land register found no contamination record for the site. A search on POEO public register was conducted for Environment Protection licences, applications, notices, audits, or pollution studies, and reduction programs. No result was found for this site. No listed history is present on this site.

One fuel tank was located with the area of the propose building. This fuel tank has been removed and validation results show that no contamination was present. The excavation for the tank has been backfilled with selected raw gravel material obtained from a local gravel pit. The gravel was obtained from raw materials in a clean gravel pit and therefore consistent with uncontaminated fill material.

The following photograph shows the excavated pit and a stockpile of soil from beneath the tank.

Figure 6: Fuel tank was located in northwest sector of Respite Centre facility.



The is no other contamination on the site of the western units to be established.

3.3.4.2 *State Environmental Planning Policy (Transport and Infrastructure) 2021*

The Transport and Infrastructure (2021) SEPP relates to development that constitutes traffic generating development. Schedule 3 of the SEPP provides a list of developments that must be referred to Transport for NSW (TfNSW).

The proposed development is not considered to be a traffic generating proposal under the Transport and Infrastructure (2021) SEPP, as it will not generate 200 or more traffic movements per hour.

3.4 Local Planning Instruments

3.4.1 Gwydir Local Environmental Plan 2013

Land Use Zoning

The proposal falls under the *Gwydir Local Environmental Plan 2013 (LEP)*. The development site is located in the area of land zoned RU5: Village. The majority of residential land in Warialda is zoned similarly.

Objectives of Zone RU5: Village

The objectives of Zone RU5 are:

- To provide for a range of land uses, services and facilities that are associated with a rural village.

Comment:

The proposal consists of respite centre thus, the use of the land conforms with the zoning of the area. It is noted that respite centre is permissible development of land zoned as RU5 under the LEP.

The respite centre will provide emergency accommodation for local residents and disaster recovery workers. It will also be used for day program and respite care services for local residents with disabilities and aged people when it is not required for natural disasters. Therefore, the proposed development is considered to conform to the objectives of the LEP.

3.4.2 Heritage Conservation

Part 5, Clause 5.10 of the LEP deals with heritage items and heritage conservation areas. The objectives of this clause are as follows:

- a) To conserve the environmental heritage of Gwydir;
- b) To conserve the heritage significance of heritage items and heritage conservation areas, including associated fabric, settings, and views;
- c) To conserve archaeological sites; and
- d) To conserve Aboriginal objects and Aboriginal places of heritage significance.

Comment:

The proposal is not in the vicinity of any heritage sites in accordance with Council's Local Environmental Plan or under State or Federal legislation.

3.4.3 Conflicts of Interest Policy

Gwydir Shire Council has recently adopted a Conflicts of Interest Policy. This policy relates to development being undertaken by Council. Development of these additional accommodation units in Plunkett Street is identified as a Council related development.

Several provisions in this Policy need to be clarified in relation to Council and Council staff involvement, mainly:

- In this regard, Council staff involved in the assessment are not to be involved in preparing the application;
- Risk assessment to be undertaken by the General Manager of Council to determine whether a potential conflict of interest exists between Council and assessment of the application with a determination whether the development has a risk category as low, moderate, high or very high risk of a conflict of interest;
- Consideration of the type of development in regard to scale, value, (competing) commercial interest of the community and controversy of the development;
- If the development is of high risk, the assessment must be undertaken by:
 - A consultant engaged by Council;
 - Another Council;
 - Local Planning Panel.

This report provides an independent assessment of the proposed development and therefore meets the initial provisions of this policy.

Once the application is lodged, the General Manager or a delegate must determine the risk category for the assessment of the application. If high risk, Council must outsource the development assessment in accordance with the provisions of this policy.

3.4.4 Bushfire Hazard

Section 5.11 of the LEP deals with land that is considered bushfire prone and may require bushfire hazard reduction work. Bushfire hazard reduction work authorised by the *Rural Fires Act 1997* may be conducted on any land without development consent.

Bushfire hazard reduction work includes the following:

- a) The establishment or maintenance of firebreak on land; and
- b) The controlled application of appropriate fire regimes or other means for the reduction or modification of available fuels within a predetermined area to mitigate against the spread of a bushfire.

But does not include construction of a track, trail, or road.

Comment

The proposed development will be located on existing cleared land. The NSW Planning and Environment Property Report tool does not identify the property as Bushfire Prone Land.

3.4.5 Earthworks

Part 6, Clause 6.1 of the LEP deals with development requiring earthworks. The objective of this clause is to ensure that earthworks where development consent is required will not have a detrimental impact on environmental functions and processes, neighboring uses, cultural or heritage items or features of the surrounding land. Development consent is required for earthworks unless:

- a) The earthworks are exempt development under this Plan or another applicable environmental planning instrument; or
- b) The earthworks are ancillary to development that is permitted without consent under this Plan or to development for which development consent has been given.

Before granting development consent for earthworks (or for development involving ancillary earthworks), the consent authority must consider the following matters:

- a) The disruption of, or any detrimental effect on, drainage patterns and soil stability in the locality of the development;
- b) The effect of the proposed development on the likely future use or redevelopment of the land;
- c) The quality of the fill or the soil to be excavated, or both;
- d) The effect of the proposed development on the existing and likely amenity of adjoining properties;
- e) The source of any fill material and the destination of any excavated material;
- f) The likelihood of disturbing relics;
- g) The proximity to, and potential for adverse impacts on any watercourse drinking water catchment or environmentally sensitive area;
- h) Any appropriate measures proposed to avoid, minimise, or mitigate of the development.

Comment:

The proposal entails minor earthworks for the site involving minor levelling of the land and placement of gravel in the carport area between the units. There will be no detrimental impact on environmental functions and processes, neighboring uses, cultural or heritage items or features of the surrounding land. If fill is to be brought to the site, it will be in the form of natural local gravel obtained from existing gravel pits. The material will be raw gravel and not recycled fill material.

3.4.6 Draft Environmental Planning Instruments

No draft environmental planning instruments apply to this proposal.

3.4.7 Development Contribution Plan

The *Section 94 Development Contribution Plan No. 1 – Traffic Generating Development (2011)* provides for an assessment of development proposals that may result in significant damage to bitumen sealed and/or gravel public roads.

The proposed development is not considered a traffic generating development, as the proposal will not result in an increase in traffic on public roads.

3.4.8 Development Control Plans

Gwydir Shire Council does not currently have a development control plan.

4 Environmental Assessment

Items considered include matters set out under Section 79C of the *Environmental Planning and Assessment Act 1979*.

4.1 Location

The site is located within a RU5-Village zone in Warialda under Gwydir Shire and is within residential area, the adjoining properties are also residential properties. The site is not currently in use, but previously the site was used as a mechanical workshop and a range of other service facilities.

The site adjoins a small retirement village on its western boundary. An old church is located on the eastern side of Plunkett Street. The Warialda Public School is located east of the church. The southern and northern boundaries adjoin private residences.

The site is centrally located within Warialda. Based on Bushfire Survival Map prepared by NSW RFS, the southern part of the site is prone to ember attack but the northern edge is marked in a "Be aware" zone for embers. Based on this mapping, it is an ideal location for emergency worker accommodation including Rural Fire Service workers employed to Warialda in the event of a bush fire disaster.

The site is considered as flood free from floods generated from Warialda Creek.

The proposed site for the emergency accommodation and respite centre in Warialda is considered appropriate to the land zoning and location.

4.2 Land Contamination

The subject site is not listed as contaminated under the NSW EPA Contaminated Land Register.

The site was previously used as shop which included the sale of fuel. Three below ground fuel tank sites were located during the site inspection of the whole property. The fuel tank beneath the proposed development site has been removed and validation results show that the tank had not contaminated the surrounding soil.

The site's potential for contamination is discussed in Section 3.3.4.1, in accordance with the *Resilience and Hazards SEPP 2021*.

No surface contamination was observed. Two fuel tanks located on land approved for development under DA 9/2023 remain under consideration of Council (The applicant). These tanks have been disused for a period of more than 30-years and therefore the likelihood of any remaining fuel contamination is extremely low. If a fuel leak had occurred in the past, the fuel would have natural biodegraded or washed away in local shallow aquifers.

It should be noted that potential activity on the site will include a playground. On this basis, threshold levels for hydrocarbon onsite during any remediation work will need to be the most stringent. The site will be classified as 'Residential A' under the Schedule B(1) – Guideline on Investigation Levels for Soil and Groundwater. Residential A includes children's day care centres where soil is accessible.

The development site on Lot 1 DP158301 is removed from the potential contamination that may be present around the original buildings on Lot 19 DP759052.

4.3 Air Quality

The proposed development is a respite centre and therefore no dust would be generated from the use of the facility. Some minor dust may be generated during site preparations. This can be avoided if a water truck is used during earthworks preparation.

The proposed development is within a developed residential area. The access to the site is via Plunkett Street which is bitumen sealed road with low potential of generating dust. Also, the internal road within the site will be sealed with either bitumen or concrete to minimize the potential for dust generation.

4.4 Water Resources

The closest surface water is Warialda Creek, located approximately 275m north of the proposed development site. The creek is ephemeral and is a tributary of the Gwydir River.

Potential impacts on water quality as a result of the proposed development may occur indirectly as a result of:

- Ground disturbance causing erosion and sediment transport during construction phase of the project; and

The implementation of appropriate mitigation measures will ensure that the potential impact to waterways is minimised. The following measures are recommended for the proposal:

- Implement temporary erosion and sediment control structures such as straw bales or a silt fence to minimise the potential for sediment laden runoff to enter watercourses during the construction phase;
- Re-establishment of ground cover on disturbed or bare soil areas once the building work is completed.

The proposed emergency accommodation and respite centre buildings will be a prefabricated structure which allows most of the work to be done offsite. Only limited site disturbance is required for construction of the building. This will include plumbing and electrical work.

Provided that the mitigation measures prescribed above are implemented during the construction phase, and that standard best management practices are implemented during the operational phase of the development, the proposed respite centre will have minimal impact on the overall condition of the waterways.

4.5 Noise Impacts

The background sound level in towns such as Warialda are characteristically low due to lack of intensive business or industrial activity. Typically, ambient levels are in the range of 25 to 45 dBA. However, seasonal factors, both natural (e.g. cicada, frog or bird activity) and anthropogenic (e.g. harvesting, pesticide spraying, or other seasonal farming operations) may ordinarily produce higher background levels. In contrast, factors such as night-time inversion layers and low wind speeds, which may be more pronounced in rural areas, may also act to increase propagation or decrease attenuation in these areas.

Existing noise levels within the area include the Warialda Public School which would generate noise when children are utilising the playground. Some traffic noise would be generated along the Gwydir Highway which is located approximately 80m to the south of the site. Noise from the highway would be dominated by truck noise throughout the day. The development site is surrounded by residential related development. Noise levels are low outside of school hours.

The proposed development will generate some light traffic noise during periods when emergency workers utilise the facility for accommodation. Outside of these periods, some external noise may be generated from children or others utilising the facility for respite services. The noise generated will be similar to existing noise levels in the local area such as light traffic within Plunkett Street and children playing.

The emergency accommodation would be used for cooking and sleeping, therefore minimal external noise would be generated by such activity.

4.5.1 Construction Noise

Acceptable Noise Generation Criteria

The NSW Noise Policy for Industry 2017 (NPI), published by the EPA, provides noise generation guidelines for developers and consent/approval authorities, to enable potential noise impacts to be predicted and mitigated where required.

The guidelines identify the Project Noise Trigger Level (PNTL) for industrial developments. The PNTL is a level that, if exceeded, would indicate a potential noise impact on the community, and would ‘trigger’ a management response, such as mitigation of noise generation. The NPI notes that the PNTL is *not* intended for use as a mandatory noise threshold requirement, but rather a planning tool.

The NPI identifies that the PNTL, feasible and reasonable noise mitigation measures, and consideration of residual noise impacts should be used together to assess noise impacts and manage noise for a development site. It is the combination of these elements that is designed to ensure decision makers determine acceptable noise outcomes.

The NPI presents a methodology for determining PNTL for industrial development. The following table provides the NPI minimum Rating Background Level (RBL) for each period of the day, which were adopted for the site.

Table 3 : Rating Background Noise Levels

Period	RBL dB(A)
Day	35
Evening	30
Night	30

Note: Day is defined as the period from 7am to 6pm (Monday to Saturday) and 8am to 6pm (Sundays and public holidays). Evening is defined as the period from 6pm to 10pm. Night is defined as the period from 10pm to 7am (Monday to Saturday), and 10pm to 8am (Sundays and public holidays).

The following table provides an analysis of both the intrusiveness and amenity noise levels for the purposes of establishing a PNTL for the proposed development.

Table 4 : Assessment of PNTL in adjacent receiving environment

Metric	Day dB(A)	Evening dB(A)	Night dB(A)
Rating Background Level	35	30	30
Project Intrusiveness Criteria	40	35	35
Recommended Amenity Level	50	45	40
Project Amenity Level	45	40	35
Project Noise Trigger Level	40	35	35

The PNTL for the project is identified to be 40, 35, and 35 dB (A) for day, evening, and night periods respectively. These noise thresholds are considered to provide a guideline for noise levels above which some noise impacts on the community may be experienced. They are not considered to be mandatory thresholds, rather noise levels which may ‘trigger’ a management response.

Construction Noise

Construction activity would be restricted to daytime according to the Noise Policy for Industry (NSW, 2017). Typical sound levels of construction plant and equipment are shown in the following table.

Table 5 : Typical Sound Levels of Construction Plant and Equipment

Plant Description	A-weighted sound power levels L _{WA} dB		A-weighted sound pressure levels L _{pA} (mid-point) dB at 10m
	Typical Range	Typical (midpoint)	
Hand tools (cordless electric)	78- 94	85	85
Truck (>20 tonne)	107	107	79
Vehicle (light commercial e.g. 4WD)	100-111	106	78

Noise impacts associated with the project were estimated using the distance attenuation relationship described in the following equation:

$$L_2 = L_1 - 20\text{Log}(d_1/d_2)$$

(Source: Noise Guide for Local Government - epa.nsw.gov.au)

- Where:
- d₁ = distance (m) between source and receiver
 - d₂ = distance (m) at which Sound Pressure (L_{pA}) measured
 - L₂ = sound pressure level at the distance d₁ from the source
 - L₁ = sound pressure level at distance d₂ from the source

Propagation calculations consider sound intensity losses due to hemispherical spreading, with additional losses such as atmospheric absorption, directivity, ground absorption and shielding.

Predicted Construction Noise Levels at Nearest Receptor

The closest receptor is approximately 20m to the north of the project site. At this distance, the loudest activity (front end loader) is predicted to be:

$$L_2 = 85 - 20 \log (20/10) = 79 \text{ dB}$$

Construction works will be confined to daytime hours, in which the acceptable noise threshold criteria is 40 dB. The proposed works would therefore exceed the threshold at certain times. Note that the majority of construction works to be undertaken on site will not be continuous. The noise would be intermittent for periods of several minutes only. This calculation therefore represents a ‘worst-case scenario’ for a short period.

Noise Mitigation Measures and Residual Noise Impact

The NPI notes that the PNTL should not be considered to be a mandatory threshold, yet rather a planning tool. The PNTL should be considered in conjunction with feasible and reasonable noise mitigation measures, and residual noise impacts. Residual noise impacts are defined as

the best achievable noise level from a development, when the development noise emissions still exceed the PNTL (following implementation of noise mitigation measures).

It is noted that there are limited feasible and reasonable noise mitigation measures which may be adopted during the construction period which would result in lowering the PNTL.

Determination of Significance of Residual Noise Impact

The NPI identifies the significance of a residual noise impact of >5dB as 'Significant'. It is therefore considered that construction works associated with the proposed development will have a significant impact upon the amenity of the surrounding location. Heavy machinery operating on the site will be audible at the closest residence, however these closest residences would also be or have recently been subject to noise from vehicles driving through Plunkett Street which would be similar in characteristic. It is further noted that the specific construction works associated with the proposed development will be temporary in nature (1 day) and will not result in continuous noise impacts on local amenity values.

Overall, it is considered that the potential noise related impacts of construction work upon the community is within an acceptable threshold. In relation to mitigation measures, the applicant or its contractors should advise the adjoining neighbours when such impacts are to occur and therefore allow the adjoining residents some warning in advance.

4.5.2 Operational Noise

The proposed activity onsite will not result in significant operational noise as this site is considered to operate in times of natural disaster which are infrequent, or temporary accommodation of respite care. The occupancy of this site is on temporary occasions.

4.6 Waste

A minor amount of waste will be generated during the construction phase and would be classified as general solid waste (non-putrescible). Wastes would predominantly include a minor amount of building waste from bracing and tie downs used during transport of the building.

Domestic waste would be generated during the operational phase by the dwelling occupants. The waste generated during the operational phase would include putrescible products. A curb-side waste collection service is available in the Warialda, and this will be utilised for general household waste generated from the respite centre.

All building waste generated on the site would be transported to the Warialda Waste Management Facility, located on Rubbish Depot Road. The facility is operated by the Gwydir

Shire Council. The facility accepts general household waste, recyclable materials, and scrap metals.

Waste will be transferred from the property to the facility in the Applicants' vehicles. Waste will be covered during transportation and containers used to transport waste would be checked to ensure they are safely secured to the vehicle.

The site will be connected to the Council sewerage system. Wastewater generated by the proposed development will be disposed via Council sewerage system.

4.7 Natural Hazards

The land is geologically stable and not subject to volcanism, earthquake, or soil instability such as subsidence, slip or mass movement.

4.7.1 Bushfire Risk

The proposed development site is not identified as Bush Fire Prone Land (BFPL) on the NSW ePlanning Spatial Viewer.

4.7.2 Flooding and Stormwater

The site is located approximately 275m north of Warialda Creek. The proposed development site is located within the Gwydir Shire's designated flood free zone.

The proposed development footprint will not significantly alter drainage patterns on site or change the ingress/movement of local overland flow.

4.8 Cultural Heritage

4.8.1 Indigenous Heritage

The Aboriginal Heritage Information Management System (AHIMS) is a database operated by OEH and regulated under section 90Q of the *National Parks and Wildlife Act 1974*. AHIMS contains information and records related to registered Aboriginal archaeological sites (Aboriginal objects, as defined under the Act) and declared Aboriginal places (as defined under the Act) in NSW.

A search of AHIMS was conducted on the 7th June 2023 to identify registered (known) Aboriginal sites or declared Aboriginal places within or in the vicinity of the subject area, Lot 1 DP 158301 with a buffer of 200 metres. The search did not reveal the presence of any known Aboriginal heritage sites or places. A copy of the search results is included in appendix 2.

The proposed development site has been subject to extensive disturbance during the development of the property for infrastructure purposes. The proposal site does not retain

any original vegetation that may be considered Scar Trees. It is noted that the proposed works only include minor earthworks for the construction of the emergency accommodation and respite centre, such that the probability of disturbing aboriginal heritage objects is relatively low.

It is therefore recommended that the project proceed on the basis that if items or sites of cultural heritage are identified during the works, this work should cease until further investigation is undertaken in accordance with the recommendations of traditional owners. However, appropriate protocols should be adopted on the site. NSW OEH recommend that the following unanticipated finds procedure is adopted:

If any Aboriginal object is discovered and/or harmed in, or under the land, while undertaking the proposed development activities, the proponent must:

- *Not further harm the object*
- *Immediately cease all work at the particular location;*
- *Secure the area so as to avoid further harm to the Aboriginal object;*
- *Notify OEH as soon as possible on 1300 555 727, providing any detailed of the Aboriginal object and its location;*
- *Not recommence any work at the particular location unless authorised in writing by NSW Environment and Heritage.*

4.8.2 Non-indigenous Heritage

No non-indigenous heritage items have been found near the development site, nor is the development site listed under Schedule 5: Environmental Heritage; of the LEP.

4.9 Flora and Fauna

The site surface is in a highly disturbed state from previous land use. The proposed development is not considered to create any risk to flora and fauna in the local area as the site is located within a well-established residential area.

4.10 Visual Impacts

The proposal will result in the erection of a new buildings in Plunkett Street.

The lot already contains several buildings, sheds of varying dimensions, an old disused shop and service facility. The addition of the proposed development on the site is not considered to result in any significant degradation of visual amenity in the locality.

The development will include some landscaping and retain existing lawn areas which will ensure the new building will conform to similar residential buildings in the street.

4.11 Access, Traffic and Parking

The site will be accessible via the existing property entrance off Plunkett Street on the east.

The proposal will generate a minor amount of traffic during emergency events where accommodation will be provided to emergency workers or local residents forced to evacuate their homes. The alternative use of the site for disability day program and respite services is expected to generate between 3 and 5 vehicles per day.

At present, Council has already secured an approval for the development of two similar structures on the site. The previous uses of the site would have generated a similar number of vehicles on a daily basis and therefore, the development is not considered as a traffic generating proposal.

Overall, the subject site is considered to have suitable site access and will include provision for parking. Provision for onsite parking is included in the development plan as the parking spaces along Plunkett Street is used to support parking for the adjoining Warialda Public School and local residences.

4.12 Services and Utilities

The site has access to all the services that it requires, including power, water, phone, and road access. The site is serviced by the Council's sewage system. The proposed development's wastewater will be disposed of through the Council sewerage system.

4.13 Social and Economic Impacts

The proposed respite centre will provide temporary accommodation for the people in the region in the time of natural disasters such as bush fires and short-term care for aged people and people with disabilities in the region. These services are lacking in Warialda, and this is the reason that the applicant has received funding to develop the facility.

It is noted that Warialda is surrounded by woodland which has been identified by NSW RFS as a risk to the town during a bushfire. Mapping shows the part of Warialda located between Warialda Creek and the Gwydir Highway as the safest area to evacuate local residents in the event of a large bushfire which threatens housing around the edge of the town area. On this basis, the proposed development has significant positive community benefits to the town in an extreme bush fire event.

Additionally, the provision of facilities for day program, aged people and people with disability is currently lacking in Warialda. The alternative for families needing respite care is to utilise facilities in Inverell. This is an economic inconvenience and therefore the provision for such services in Warialda will have an economic benefit to those families. The facilities will also

promote regional economic resilience by providing jobs for aged care workers and disability support workers. This may result in such specialists living in Warialda.

4.14 Cumulative Impacts

The potential environmental impacts from the establishment and operation of the proposed respite centre have been detailed in their relevant sections throughout this report.

The proposal is unlikely to have any adverse environmental impacts on flora, fauna or heritage. When considered in the context of the zoning and surrounding land uses, it is concluded that it is unlikely for adverse cumulative impacts to result from this proposal.

The respite centre is predicted to produce positive economic and social benefits for the surrounding region by offering temporary accommodation for people in the region during emergency situations.

5 Conclusion and Recommendations

This Statement of Environmental Effects provides an investigation into the proposed construction and operation of an additional emergency accommodation facility and respite centre at 32 Plunkett Street in Warialda. The findings of this Statement of Environmental Effects include the following:

- The proposal is considered to comply with local planning guidelines and meets the objectives of the *Gwydir Local Environmental Plan 2013* and applicable *Development Control Plans*;
- The proposal is consistent with the surrounding land uses and can meet all applicable setback distances;
- The proposal is not considered to have any significant environmental impact and does not pose any significant conflict with the amenity of the area; and
- The proposal is recognised to have positive benefits to the local community by providing emergency accommodation and a respite centre for which the town does not have at present.

The site for the additional buildings has been remediated as part of work undertaken for DA 9/2023. No parameters of concern remain for the establishment of two additional 3-bedroom units on Lot 1 DP158301.

Appendix 1- Building Plan for the two by three-bedroom unit

22-408B Warialda Respite Centre

Statement of Environmental Effects

C:\GDP_Scott Group\JPG - Customers - Customers\Gwydir Shire Council\3961_Hospital Accommodation Units\3961_2A Three Bedroom Braidwood Cabin.jpg

proposed Three Bedroom Braidwood Cabin
for
Gwydir Shire Council
13/03/2023



Uniplan Group Pty Ltd
22 Myrtle Drive | PO Box 5004 | Armidale NSW 2350
t + 61 2 6773 8500 | FREECALL 1 800 UNIPLAN
www.uniplangroup.com.au | email sales@uniplangroup.com

This drawing may contain items or elements of work which are shown for indicative purposes only and are not included in the Contract price unless expressly noted in the Specification or other Contract Documents. Drawings are protected by copyright and remain the property of Uniplan Group. No part of this document may be reproduced or copied without permission of Uniplan Group. All site dimensions and levels are to be verified and confirmed by the client prior to the commencement of works.

sheet index

sheet no	sheet name
01	cover page
02	floor plan
03	site plan



client:
Gwydir Shire Council
project:
proposed Three Bedroom Braidwood Cabin
Warialda

drawn by: dh

scale: 1:62, 1:1.50, 1:1
on A3

date: 13/03/2023

cover page

job no:	sheet no:
3961_1A	-1



22-408B Warialda Respite Centre

Statement of Environmental Effects

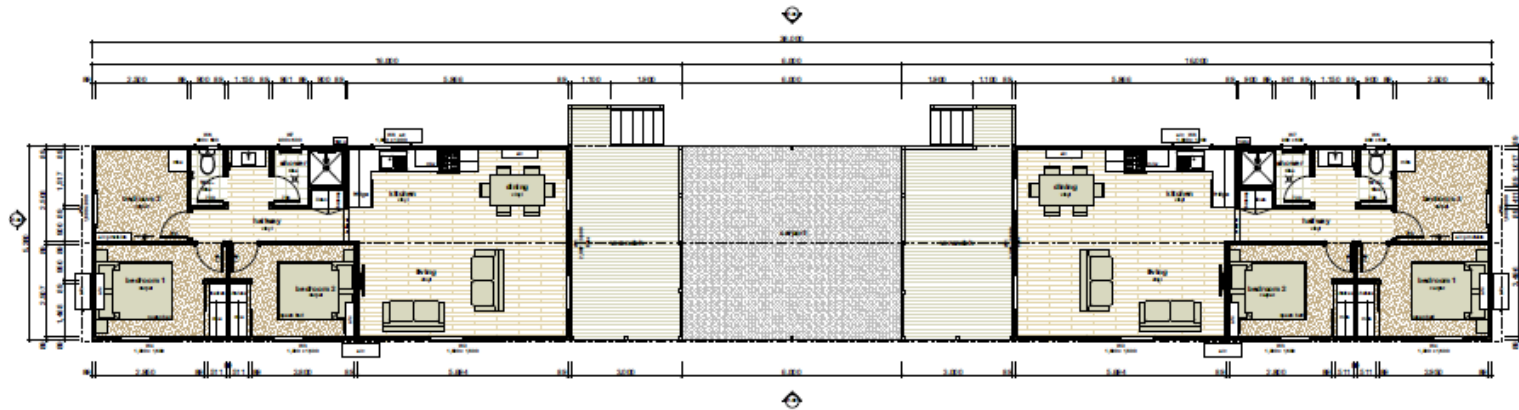



 <p>UNIPLAN Modern forms, functional design</p> <p>Uniplan Group Pty Ltd 22 Myrtle Drive PO Box 5004 Armidale NSW 2350 t: + 61 2 6773 8800 FREECALL: 1800 UNIPLAN www.uniplangroup.com.au email: sales@uniplangroup.com.au</p>	<p>This drawing may contain items or elements of work which are shown for illustrative purposes only and are not included in the Contract price unless expressly noted in the Specification or other Contract Documents.</p> <p>Drawings are prepared by copyright and remain the property of Uniplan Group. No part of this document may be reproduced or applied without permission of Uniplan Group.</p> <p>All size, dimensions and levels are to be verified and confirmed by the client prior to the commencement of works.</p>	<p>client: Gwydir Shire Council</p>	<p>drawn by: dh</p>	<p>floor plan</p>	
		<p>project: proposed Three Bedroom Braidwood Warialda</p>	<p>scale: 1:150, 1:100 on A3</p> <p>date: 13/03/2023</p>	<p>job no: 3961_1A</p>	<p>sheet no: -2</p>

SMK
CONSULTANTS

22-408B Warialda Respite Centre

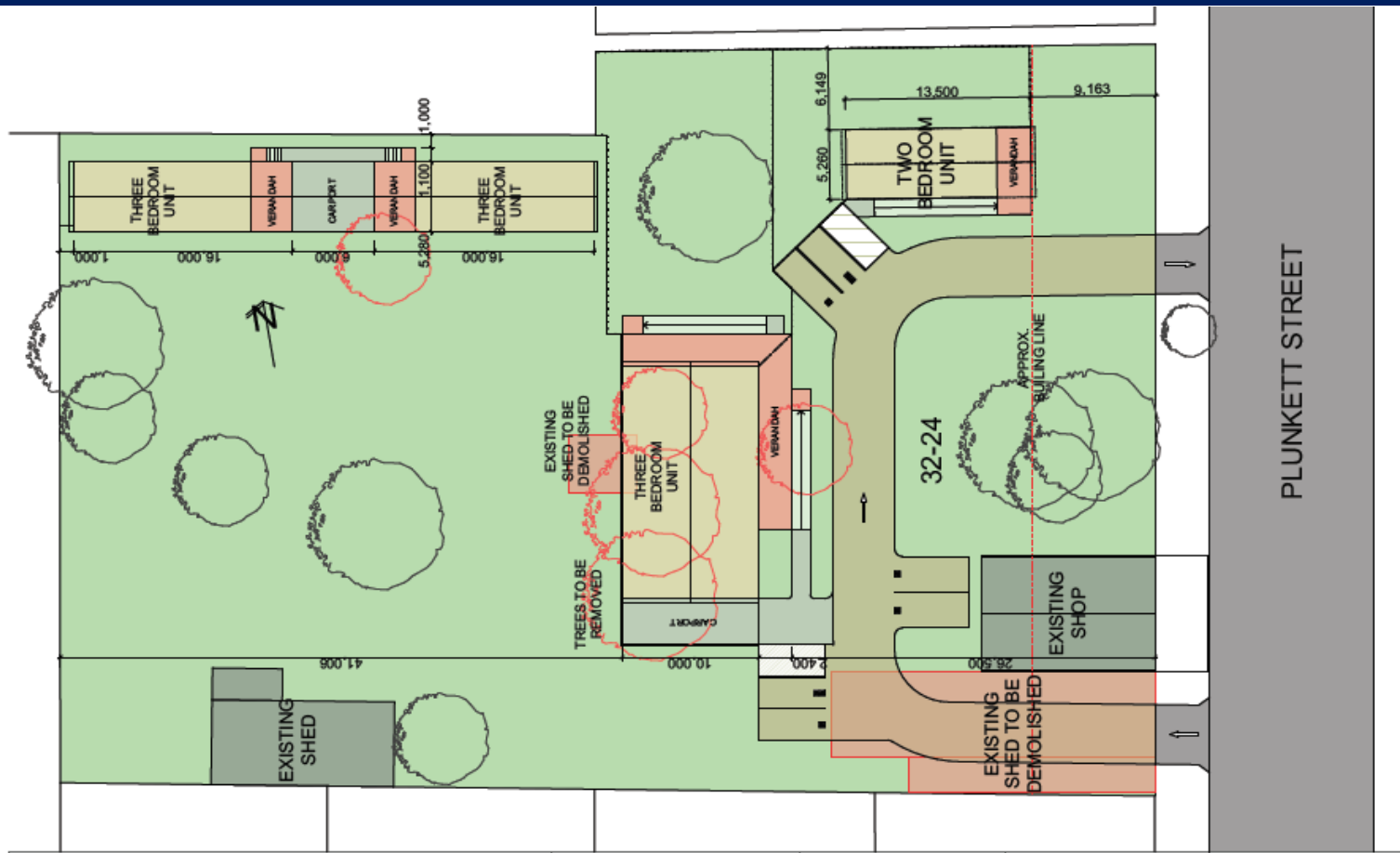
Statement of Environmental Effects



 <p>UNIPLAN Modern forms. Functional design.</p>	<p>Uniplan Group Pty Ltd 22 Myrtle Drive PO Box 5004 Armidale NSW 2350 t: + 61 2 6773 8500 FREE CALL: 1800 UNIPLAN www.uniplan.com.au email: info@uniplan.com.au</p>	<p>This drawing may contain items or elements of work which are shown for indicative purposes only and are not included in the Contract price, unless expressly noted in the Specification or other Contract Documents. Drawings are protected by copyright and remain the property of Uniplan Group. No part of this document may be reproduced or copied without permission of Uniplan Group. All site dimensions and levels are to be set out and confirmed by the client prior to the commencement of works.</p>	<p>client: Gwydir Shire Council</p>	<p>drawn by: dh</p>	<p>site plan</p>
			<p>project: proposed Three Bedroom Braidwood Warialda</p>	<p>scale: 1:250 on A3 date: 13/03/2023</p>	<p>job no: 3961_1A</p>

SMK
CONSULTANTS

22-408B Warialda Respite Centre

Statement of Environmental Effects

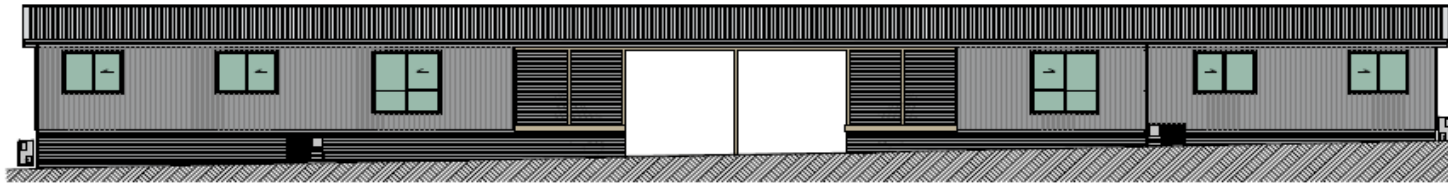

E-02 | side elevation
1:100

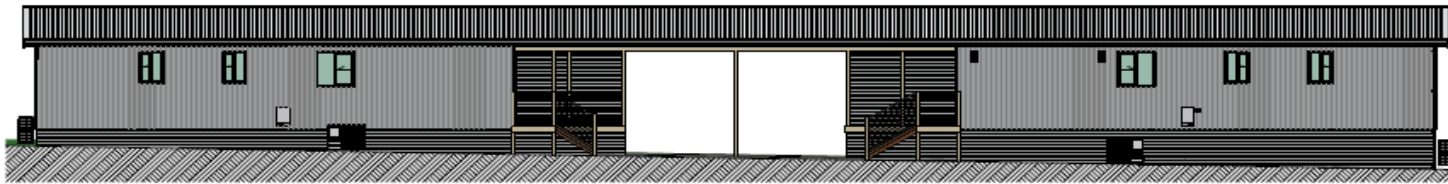

E-04 | side elevation
1:100



E-01 | front elevation
1:100



E-03 | back elevation
1:100

glazing schedule

window no.	W1	W2	W3	W4	W5	W6	W7	W8
type	Sliding Door	Sliding Window	Sliding Window	Sliding Window	Double Hung Window	Sliding Window	Sliding Window	Sliding Window
glazing	Clear Glass	Clear Glass	Clear Glass	Clear Glass	Clear Glass	Obsc. Glass	Obsc. Glass	Clear Glass
height	2,082	1,800	1,200	1,200	1,800	900	900	1,000
width	3,600	1,800	1,000	1,000	900	900	600	1,000
qty	2	2	2	2	2	2	2	2
ext view								

<p>UNIPLAN GROUP Modern forms, functional design</p> <p>Uniplan Group Pty Ltd 22 Myrtle Drive PO Box 5004 Armidale NSW 2350 t: + 61 2 6773 8500 FREECALL: 1800 UNIPLAN www.uniplangroup.com.au email: sales@uniplan.com.au</p>	<p>This drawing may contain items or elements of work which are shown for illustrative purposes only and are not included in the Contract price unless expressly noted in the Specification or other Contract Documents.</p> <p>Drawings are protected by copyright and remain the property of Uniplan Group. No part of this document may be reproduced or copied without permission of Uniplan Group.</p> <p>All site dimensions and levels are to be verified and confirmed by the client prior to the commencement of works.</p>	<p>client: Gwydir Shire Council</p> <p>project: proposed Three Bedroom Braidwood Warialda</p>	<p>drawn by: dh</p> <p>scale: 1:100, 1:1.50 on A3</p> <p>date: 13/03/2023</p>	<p>elevations</p> <p>job no: 3961_1A</p> <p>sheet no: -4</p>
--	--	---	---	--

Appendix 2 – AHIMS Search (Aboriginal Heritage Information Management System)



AHIMS Web Services (AWS)
Search Result

Your Ref/PO Number : 22-408
Client Service ID : 789005

Bruno Nwokolo
39 Frome Street Heber Street
Moree New South Wales 2400
Attention: Bruno Nwokolo
Email: bruno@smk.com.au

Date: 07 June 2023

Dear Sir or Madam:

AHIMS Web Service search for the following area at Lot : 1, DP:DP158301, Section :- with a Buffer of 200 meters, conducted by Bruno Nwokolo on 07 June 2023.

The context area of your search is shown in the map below. Please note that the map does not accurately display the exact boundaries of the search as defined in the paragraph above. The map is to be used for general reference purposes only.



A search of Heritage NSW AHIMS Web Services (Aboriginal Heritage Information Management System) has shown that:

0	Aboriginal sites are recorded in or near the above location.
0	Aboriginal places have been declared in or near the above location. *

4 September 2023

Dear Sir/Madam

We write in Reference to the Notice of Development Application No 29/2023 – 32 Plunkett Street Warialda NSW 2402

As the owners of 16 Geddes Street Warialda, we are writing to you expressing some concerns we have with the Development Application No 29/2023 - 32 Plunkett Street Warialda.

Firstly, can we convey we are not opposed to development but have some concerns about some aspects of this development that will detrimentally affect the enjoyment of our land and home. These concerns we believe can be easily rectified by the developer and will as a result if addressed, positively assist us the neighbours of the proposed development and those who will be living in the proposed development. This will in turn create a win-win situation, be relatively inexpensive and make for good neighbours into the future.

We are suggesting that council consider extending our boundary fence with a lightweight material such as lattice or the like by two to three feet. Lattice would be light weight in structure and not compromise the strength of the existing boundary fence. This will in turn create privacy for us and the occupiers of 32 Plunkett Street.

Without such an extension to the fence we are concerned our privacy will be severely compromised in two ways –

1. We are concerned that vehicles using the proposed carport in the development at 32 Plunkett Street, will if driving at night direct their headlights into our home. This will result in car lights directly shining into our kitchen and bedroom window.
2. We also feel that due to the location of the proposed development it will result in having a direct view into each other's homes between us and the future occupiers of 32

Plunkett Street. This will prevent any privacy and impact on the enjoyment we currently have on our verandah and in our yard, where we spend a lot of time both day and night.

We feel this request for consideration is not unreasonable and will improve the living standards for all concerned.

We are more than happy to speak further on this matter and would like to be included in the planning on any boundary fence improvements that may take place to address our concerns.

Yours faithfully

Claude and Vickie McClymont

16 Geddes Street Warialda

A handwritten signature in black ink that reads "Vickie McClymont". The signature is written in a cursive style with a small flourish at the end.

9.4 April 2024 Investment and Rates Collection Report

File Reference: NA
Delivery Program
Goal: 5. Organisational management
Outcome: 5.1 Corporate management
Strategy: 5.1.1 Financial Management and accountability systems
Author: Helen Thomas, Chief Financial Officer

STAFF DISCLOSURE OF INTEREST Nil

IN BRIEF/SUMMARY RECOMMENDATION

At each monthly Ordinary Meeting, the Council is presented with the schedule relating to Investments, as at the end of the previous month.

TABLED ITEMS Nil

BACKGROUND

In accordance with Clause 19(3) of the Local Government (Financial Management) Regulation 1993, the following information provides details of Council's funds invested as at 30 April 2024.

Direct Investments

Broker	ID	Investment Name	Rating	Type	Next Rollover	Yield	Current Value
NAB	2023.01	NAB	AA	TD	22/05/2024	4.25%	\$1,000,000.00
NAB	2023.02	NAB	AA	TD	22/05/2024	4.25%	\$1,000,000.00
NAB	2023.03	NAB	AA	TD	22/05/2024	4.25%	\$1,000,000.00
Grand Total							\$3,000,000.00

Managed Funds

Fund	Investment Horizon	Type	Yield	Current Value
Regional Australia Bank	At Call	Cash		\$369,457.35
Regional Australia Bank Medical Centre	At Call	Cash	3.00%	\$51,500.00
Grand Total				\$420,957.35

Total Investments

Direct Investments	\$3,000,000.00
Managed Funds	\$420,957.35
Grand Total	\$3,420,957.35

Cash and Investments

Total Investments	
Direct Investments	\$3,000,000.00
Managed Funds	\$420,957.35
Grand Total Investments	\$3,420,957.35

Total Cash and Investments	
Investments	\$3,420,957.35
Cash at bank	\$24,194,798.05
Grand Total Cash and Investments	\$27,615,755.40

General Fund Cash	
Total cash and investments	\$27,615,755.40
LESS:	
Water fund*	-\$1,338,389.00
Sewer fund*	-\$1,388,794.00
Waste fund*	-\$4,552,202.00
Other restrictions:	
Employee leave entitlements*	-\$1,000,000.00
Asset replacement*	-\$830,000.00
Bonds and deposits	-\$2,659,851.00
Unexpended grants*	-\$5,934,476.00
Developer contributions	-\$806,596.00
Internal Restrictions	-\$5,000,000.00
Discretionary General Fund Cash	\$4,105,447.40

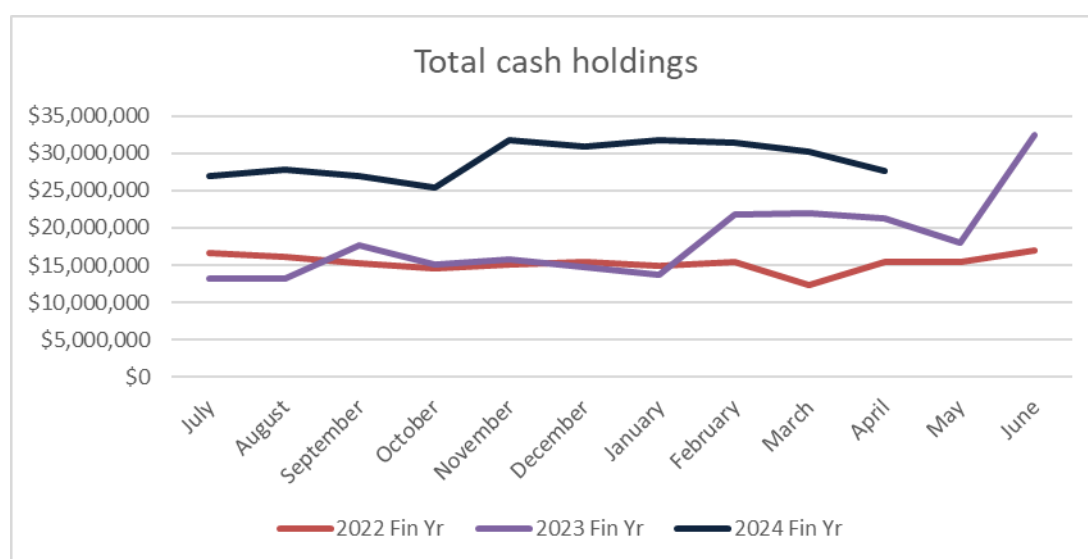

I, Helen Thomas, CFO and Responsible Accounting Officer for Gwydir Shire Council, certify that the Council’s investments have been made in accordance with the Local Government Act 1993, Local Government (General) Regulation 2005 and Council’s Investment Policy, as amended.

RATES COLLECTIONS

The graph below represents a comparative of the percentage collections for the current year against the two previous rating years. The current years collections are up to 30 April 2024.

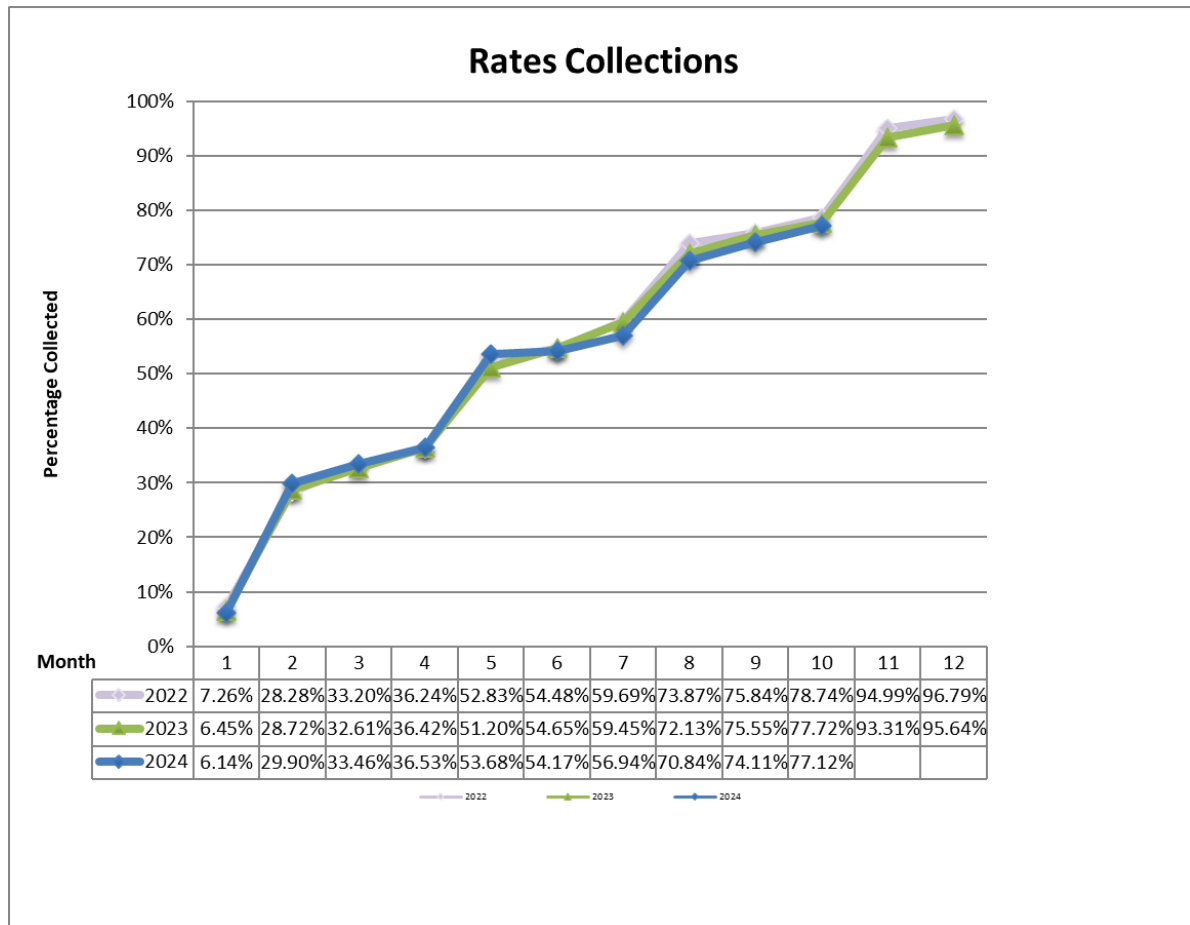

OFFICER RECOMMENDATION

THAT the April Monthly Investment and Rates Collection report be received.

ATTACHMENTS

Nil

COUNCIL RESOLUTION:

THAT the April Monthly Investment and Rates Collection report be received.

(Moved Cr Egan, Seconded Cr Mulligan)

CARRIED

For: Cr J Coulton, Cr Egan, Cr D Coulton, Cr Galvin, Cr Matthews, Cr Moore, Cr Mulligan and Cr Smith

Against: Nil

9.5 Asset Disposal Policy

File Reference: NA

Delivery Program

Goal: 5. Organisational management

Outcome: 5.1 Corporate management

Strategy: 5.1.5 Provision of responsible internal governance

Author: Leeah Daley, Deputy General Manager

STAFF DISCLOSURE OF INTEREST Nil

IN BRIEF/SUMMARY RECOMMENDATION

TABLED ITEMS Nil

BACKGROUND

This policy has been developed to provide a systematic and accountable method for the disposal of surplus assets, including real property, and to ensure the process is transparent and complies with Council's Code of Conduct, particularly with respect to conflict of interest.

COMMENT

The Policy was originally drafted in November 2007 and has been revised by relevant staff in May 2024 to include property assets and updated threshold figures.

OFFICER RECOMMENDATION

THAT The Draft Asset Disposal Policy (Property, Plant, and other Assets) revised May 2024 be adopted.

ATTACHMENTS

1. Asset Disposal Policy Draft Version May 2024 [9.5.1 - 9 pages]

COUNCIL RESOLUTION:

THAT The Draft Asset Disposal Policy (Property, Plant, and other Assets) revised May 2024 be adopted.

(Moved Cr Matthews, Seconded Cr Mulligan)

CARRIED

For: Cr J Coulton, Cr Egan, Cr D Coulton, Cr Galvin, Cr Matthews, Cr Moore, Cr Mulligan and Cr Smith

Against: Nil



Gwydir Shire Council

Draft Asset Disposal Policy (Property, Plant, and Other Assets)

File Reference: Version 2.0
Council Resolution: Pages 9

Table of Contents

Document Data	3
Revision Record	3
1. Overview	4
1.1 Objectives	4
1.2 Definitions	4
2. Policy Statement	4
2.1 Delegated Authority.....	4
2.2 Disposal Process	5
2.3 Conflicts of Interest	5
2.4 Reasons for Disposal	5
2.5 Preparing Assets for Sale	5
3. Asset Disposal Methods.....	6
3.1 Methods of Disposal of Assets.....	6
3.2 Sale to Staff/Councillors.....	6
3.3 Direct Sale.....	6
3.4 Donations to Community Groups/Charities.....	6
3.5 Destruction of Assets Classified as Beyond Economical Repair	7
3.6 Sale/Disposal of Information Technology (IT)/Computer Equipment.....	7
3.7 Sale of Motor Vehicles	7
3.8 Sale of On-Site Vans at Council's Caravan Parks	7
3.9 Sale of Office Furniture	7
3.10 Sale of Major Assets	7
3.11 Sale of Property	8
4. Asset Disposal Procedures	8
4.1 Condition for the Disposal of Assets	8
4.2 Disposal Approval Process	8
4.3 Documents Required in Support of Disposal of Minor Assets	8

Document Data

Department	Technical Services
Responsible Manager	Alexander Eddy
Date Adopted or Approved under Delegation of General Manager	
File reference	
Version no	2.0
Next Review	

Revision Record

Date	Version	Revision details	Officer
November 2007	1.0	e.g. initial document	Alexander Eddy
May 2024	2.0	Revised policy. Inclusion of property assets and updated threshold figures. Updated format.	Penelope Goodwin

1. Overview

1.1 Objectives

To provide a systematic and accountable method for the disposal of surplus assets, including real property, and to ensure the process is transparent and complies with Council's Code of Conduct, particularly with respect to conflict of interest.

1.2 Definitions

In this policy:

“Asset” means any asset item recorded in Council's Asset Register.

“Beyond economical repair or obsolete” means a classification given to an asset where that asset either requires repairs likely to be more expensive than its replacement value due to it being in a state of disrepair, unserviceable, unusable or it is considered obsolete.

“Motor vehicle” means a passenger sedan or station wagon, motorcycle or commercial motor vehicle including vans, utilities, buses, and trucks.

2. Policy Statement

2.1 Delegated Authority

With respect to the disposal of assets, the General Manager has delegated the following authorities:

Determination of the need for sale or disposal of minor assets (up to a value of \$15,000) as surplus to requirements, the asset is in a state of disrepair, unserviceable, unusable, or obsolete:

- Naroo and Aged Services Manager
- Engineering Services Director
- Chief Financial Officer

Determine the method of sale or disposal of minor assets: by public tender, auction; or direct sale:

- Engineering Services Director
- Chief Financial Officer

Fleet Vehicle disposal by trade-in, public tender and auction only, up to a net estimated changeover value of \$40,000:

- Engineering Services Director
- Town Utilities and Plant Manager
- Chief Financial Officer

Heavy Plant disposal by public tender and auction only, up to the value of \$200,000:

- Engineering Services Director

Determine the method of sale or disposal of major assets (\$10,000 and above): by public tender, auction, or direct sale (after Council has resolved to dispose of the asset as part of the Operational Plan).

- Engineering Services Director

2.2 Disposal Process

At all times, surplus assets or materials should be disposed of in a way that maximises returns whilst maintaining transparency and accountability ensuring open and effective competition.

Prior to disposal, a reasonable effort is to be made to ensure no other Council department has a need for the asset.

Items of historical or cultural significance should be given special regard, including consultation with the relevant Historical Society, and any dangerous goods disposed of only in an authorised manner.

No warranty is to be offered on assets sold.

2.3 Conflicts of Interest

The delegated officer responsible for the disposal of any Council assets and/or the relevant Director must ensure that no conflict of interest occurs in or as a result of the asset disposal process.

2.4 Reasons for Disposal

A decision to dispose of an asset may be based on one or more of the following:

- Obsolescence.
- Non-compliance with occupational health and safety standards.
- No use expected in the foreseeable future.
- No usage in the previous 6 months (Stores stock items).
- Optimum time to maximise return.
- Discovery of hazardous chemicals or materials present in the asset.
- Uneconomical to repair.

2.5 Preparing Assets for Sale

A check must be carried out to ensure assets do not contain:

- Additional items not intended for sale.
- Confidential documents (records, files, papers).
- Documents on Council letterhead or documentation which may be used for fraudulent purposes.

- Software (which could lead to a breach of licence or contain confidential data).
- Hazardous materials.

As much as is practical, any “Gwydir, Yallaroi, or Bingara Shire Council” identifying mark should be removed or obliterated.

Spare parts held for a particular item should be disposed of in one parcel with the asset.

3. Asset Disposal Methods

3.1 Methods of Disposal of Assets

The principal methods of disposal of assets are:

- a. Auction (for items of significant value a reserve price will be agreed to between the relevant officer and the auctioneer prior to the auction).
- b. Dumping – assets of no or little value only.
- c. Donation to a registered charity or community organization.

3.2 Sale to Staff/Councillors

As a general principle, the sale of assets to staff or Councillors is **NOT** to occur outside of a public process.

The Independent Commission Against Corruption (ICAC) recommends that invitations to bid for the purchase of any surplus Council assets should not be limited to staff or to elected officials. Members of the public must also be allowed to compete for the purchase.

However, it is recognised that there will be individual instances where sale to a staff member or Councillor may be the most practical or fair and reasonable manner of disposal and in accordance with other policy decisions. In these instances, authority for disposal will rest with the General Manager.

3.3 Direct Sale

The General Manager may, at their discretion, offer direct sale of fleet vehicles up to \$25,000. Under this clause, sale value is to be determined by market appraisal, or the written down value of the plant within Council's asset register.

3.4 Donations to Community Groups/Charities

(Note: this method of disposal may not be used for assets with an estimated value of more than \$4,000).

Scrap materials salvaged from works e.g. pavers etc. which are unsuitable for new Council projects may be “donated” to charities/sporting bodies with the authority of the relevant Director.

Donations of other old assets may only be made with the authority of the relevant Director and only after exploring all avenues to recoup a fair value for the Council.

Council staff should only consider donations in response to a formal written request. In considering any request, staff should keep in mind the following:

- Community groups should receive equitable treatment to avoid possible claims of bias.
- Where the donation is seen as appropriate but there is a potential claim of bias, the matter should be referred to the General Manager.
- The charity/community group must remove the assets themselves and at no cost to the Council.

3.5 Destruction of Assets Classified as Beyond Economical Repair

Where an asset is classified as beyond economic repair the asset must be destroyed, with the destruction being witnessed by another responsible officer nominated by the responsible Director.

3.6 Sale/Disposal of Information Technology (IT)/Computer Equipment

All Gwydir (including Bingara or Yallaroi) Shire Council data and software applications must be removed from any hard drives.
All external asset tags and labels connecting a machine to Gwydir Shire Council must be removed.

3.7 Sale of Motor Vehicles

Motor vehicles are to be sold via public auction, public advertisement calling for bids or trade-in. Any asset disposed of by public auction is required to be undertaken by a registered Auctioneer.

3.8 Sale of On-Site Vans at Council's Caravan Parks

In line with the Council's movement towards on-site tourist cabins at its Caravan Parks the Council will assess and dispose of its existing caravans if they are evaluated as beyond economical repair or obsolete.

Where an existing tenant exists the appropriate vacant request notice will be served in line with the legislated requirements.

3.9 Sale of Office Furniture

The Chief Financial Officer is responsible for the disposal of all office furniture. The furniture is to be sold by public auction, transfer to a community group/charity, or through publicly called offers.

3.10 Sale of Major Assets

Where assets of significant value (being more than \$50,000) are to be sold, the sale is to be by either public auction or tender.

3.11 Sale of Property

Property assets (includes buildings and land) are to be disposed of by Council resolution, or by delegated authority from the General Manager.

4. Asset Disposal Procedures

4.1 Condition for the Disposal of Assets

Where possible, assets valued at greater than \$2,000 should be disposed of by public auction, using a registered auctioneer.

4.2 Disposal Approval Process

- a. The Manager of the relevant area identifies assets that are in excess of Council requirements and are suitable for disposal.
- b. The Manager of the relevant area arranges disposal of the assets by the appropriate manner given the asset type, the parameters set down in this policy, and the issued delegation.
- c. If no offers to purchase are received or no bid for the asset at a public auction and the asset is of no or little value, the asset will be disposed of by dumping in the manner described above. If no offers to purchase the asset are received and the asset is of significant estimated value, the relevant Director will determine how to best dispose of the asset in order to maximise the return to Council whilst ensuring open and effective competition. For accountability and audit reasons, the basis of the decision must be documented.
- d. All relevant paperwork is to be filed in Council's records system, and documentation presented upon request. Failure to do so may result in a breach of Council's Code of Conduct and Procedures and/or Grievance Procedure.
- e. The Director or Manager from the relevant area (with appropriate delegated authority) approves the disposal of a particular asset.
- f. Appropriate approval from the General Manager is to be sought by the delegate wherever necessary.

- g. Notice is to be sent to the Assets Officer, who will organise the adjustment of the asset register. Failure to do so may result in the matter being flagged by the NSW Audit Office.

4.3 Documents Required in Support of Disposal of Minor Assets

A copy of the receipt or other proof of disposal from the contracted auctioneer, the licensed scrap dealer, or the supervising staff at the tip disposal site must be submitted to Council's records system.

Alternatively, a letter acknowledging receipt of asset/s from the receiving community group or charity must be obtained and submitted to Council's records system.

9.6 Draft Gifts and Benefits Policy

File Reference: NA

Delivery Program

Goal: 5. Organisational management

Outcome: 5.1 Corporate management

Strategy: 5.1.1 Financial Management and accountability systems

Author: General Manager

STAFF DISCLOSURE OF INTEREST Nil

IN BRIEF/SUMMARY RECOMMENDATION

This report recommends the adoption of the reviewed Gifts and Benefits Policy.

TABLED ITEMS Nil

BACKGROUND

The attached policy document has been reviewed and is recommended for adoption.

OFFICER RECOMMENDATION

THAT the Gifts and Benefits Policy is adopted.

ATTACHMENTS

1. Draft Gifts and Benefits Policy [9.6.1 - 3 pages]

COUNCIL RESOLUTION:

THAT the Gifts and Benefits Policy is adopted.

(Moved Cr Matthews, Seconded Cr Mulligan)

CARRIED

For: Cr J Coulton, Cr Egan, Cr D Coulton, Cr Galvin, Cr Matthews, Cr Moore, Cr Mulligan and Cr Smith

Against: Nil



Gwydir Shire Council Gifts and Benefits Policy

Department: Finance

Responsible Manager: General Manager

Date Adopted:

File Ref:

Version No: 2.0

Next Review: May 2027

Pages: 3

1. Objective

To assist Councillors and staff to determine the appropriate action to follow the respect to the acceptance or rejection of gifts and benefits.

2. Policy

Council officials, at some stage in their career may be offered a gift or benefit in the course of their work. The gift or benefit could be offered innocently in good faith or could be an attempt of influence. Feelings of obligation can arise if council officials accept a gift or benefit. Once such a gift is accepted, a council official can be compromised. Individuals attempting to corrupt council officials often start with small inducements that appear to have no improper motive behind them.

Corruptly receiving a gift or a benefit is an offence under both the common law and NSW legislation. The offence extends to the offering or seeking of a gift or benefit.

1. Councillors and staff members should not (directly or indirectly) seek or demand from any person or body any preset or promised future reward, payment, gratuity, gift, donation concession, or other benefit for themselves, or for any other person or body (including Council):
 - In connection with the performance of their office or duties.
 - In relation to services performed (or to be performed) by the Council, or which might tend (or be seen) to influence them in their official capacity.
2. Councillors and staff should not accept a gift or benefit or more than token value.

OFFERS OF MONEY IN ANY FORM SHOULD NEVER BE ACCEPTED

3. Any councillor or staff member who is offered a gift or benefit against their will should report the incident in writing to the general manager. Such report should include:
 - Date, time and place of the incident.
 - To whom the gift or benefit was offered
 - Who offered the gift and benefit and contact details (if known)
 - The response to the offer
 - Any other relevant details of the offer
4. If the situation arises where a gift of more than token value cannot reasonably be returned or refused, the person receiving the gift should hand it over as property of the Council.
5. Gifts of token value may be accepted by councillors and staff provided they do not create a sense of obligation in the receiver that will influence, or appear to influence, the exercised of his/her official duties. (For the purpose of this policy, token value is taken to be less than \$50. If more than one gift or benefit is involved the cumulative value should not exceed \$50 over a 12-month period.)
6. Councillors and staff should take reasonable steps to ensure that members of their family and relatives do not receive benefits which could give the appearance of an indirect attempt to secure influence or favour.
7. Councillors and staff should decline any offer which is individually targeted and not available generally to other councillors and employees or industry participants who share a common task or purpose. However, Councillors and staff may accept token gifts/benefits given in appreciation e.g.:

- A councillor receiving some flowers.
 - A childcare worker receiving a token gift at Christmas time e.g. cake of soap.
 - A cup of coffee offered to an outdoor staff member.
 - A plate of sandwiches offered as a working lunch.
8. A Gifts & Benefits Register is maintained in Pulse where employees and Councillors who receive a gift or benefit of more than token value must complete the form within Pulse.

A report will be presented to Council each year giving details of entries in the Gifts & Benefits Register for the previous period. Furthermore, managers will be asked at Senior management meetings as a standing item, if they have been made aware of any such Gifts or Benefits that need to be recorded.

3. Related Documents

Local Government Act 1993

Fraud and Corruption Policy

4. Revision Record

Date	Version	Revision Details	Officer
Feb 2009	1.0	Initial Document	Kirsty Smith
May 2024	2.0	Updated to the where the register is located and where to report.	Graham Cutmore

9.7 Gwydir Shire Legislative Compliance Policy

File Reference:	NA
Delivery Program	
Goal:	5. Organisational management
Outcome:	5.1 Corporate management
Strategy:	5.1.5 Provision of responsible internal governance
Author:	Leeah Daley, Deputy General Manager

STAFF DISCLOSURE OF INTEREST Nil

IN BRIEF/SUMMARY RECOMMENDATION

This report recommends the adoption of the The legislative Compliance Policy and Procedure Policy.

TABLED ITEMS Nil

BACKGROUND

The Audit Office of New South Wales has identified one of the key components of good corporate governance to be compliance management, which requires procedures to be in place that ensure an organisation complies with all relevant laws and government directions.

COMMENT

The attached policy and procedure have been developed to demonstrate Gwydir Shire Council's commitment to the Governance Standards ensuring that Gwydir Shire Council has complied with the legislation under which it operates.

The Framework outlines how Gwydir Shire Council seeks to monitor and manage risks impacting legislative compliance.

This policy applies to all council officials, including councillors, employees, and delegates, including volunteers, consultants, contractors any other service provider involved in exercising a Council function.

This policy is supported by the Legislative Compliance Procedure (see attached) and Database – Corporate Planning and Reporting module on Pulse platform.

OFFICER RECOMMENDATION

THAT The legislative Compliance Policy and Procedure as drafted in April 2024 be adopted.

ATTACHMENTS

1. Gwydir Shire Council Legislative Compliance Policy Procedure [9.7.1 - 7 pages]

COUNCIL RESOLUTION:

THAT The legislative Compliance Policy and Procedure as drafted in April 2024 be adopted.

(Moved Cr Matthews, Seconded Cr Mulligan)

CARRIED

For: Cr J Coulton, Cr Egan, Cr D Coulton, Cr Galvin, Cr Matthews, Cr Moore, Cr Mulligan and Cr Smith

Against: Nil



Gwydir Shire Council
**Legislative Compliance
Policy and Procedure**

Department: Executive Service

Responsible Manager: Governance Officer

Date Adopted: April 2024

File Ref:

Version No: 1

Next Review:

Pages:

Table Of Contents

Gwydir Shire Council	1
Legislative Compliance Policy and Procedure	1
1. Overview	3
1.1 Introduction	3
1.2 Scope.....	3
1.3 Purpose.....	3
2 Roles and Responsibilities	4
3 Risk Management	5
4 Legislative Compliance Procedure	5
4.1 Purpose.....	5
This policy applies to all council officials, including councillors, employees and delegates, including volunteers, consultants, contractors any other service provider involved in exercising a Council function.	5
4.2 Procedure.....	5
4.2.1 Identifying Current, New or Amended Legislation	5
4.2.2 Obtaining Advise on Legislative Provisions	6
4.2.3 Informing Council of Legislative Change	6
4.2.4 Reporting of Non-Compliance.....	6
4.2.5 Review of Incidents and Complaints Regarding Non-Compliance.....	6
4.2.6 Audit on Legislative Compliance.....	7
5 Related Documents	7
6 Related Legislation	7
7 Revision Record	7

1. Overview

1.1 Introduction

As part of effective corporate governance, it must be ensured that Gwydir Shire Council has complied with the legislation under which it operates.

The Audit Office of New South Wales has identified one of the key components of good corporate governance to be compliance management, which requires procedures to be in place that ensure an organisation complies with all relevant laws and government directions.

This policy and procedure has been developed to demonstrate Gwydir Shire Council's commitment to those governance standards. The Framework outlines how Gwydir Shire Council seeks to monitor and manage risks impacting legislative compliance.

1.2 Scope

This policy applies to all council officials, including councillors, employees and delegates, including volunteers, consultants, contractors any other service provider involved in exercising a Council function.

This policy is supported by the Legislative Compliance Procedure (see below) and Database – Corporate Planning and Reporting module on Pulse platform.

1.3 Purpose

To provide the systems and operating environment to ensure that Council complies with legislative requirements. Council will:

- a. Maintain a system for identifying and updating the legislation that applies to Council's activities.
- b. Assign responsibilities for ensuring that legislation and regulatory obligations are fully implemented in Council with appropriate delegations and controls.
- c. Provide training for relevant staff, Councillors, volunteers and other relevant people in the legislative requirements that affect them.
- d. Provide people with the resources to identify and remain up to date with new legislation.
- e. Conduct audits to ensure there is compliance.
- f. Establish a mechanism for reporting non-compliance.
- g. Review accidents, incidents and other situations where there may have been non-compliance.
- h. Review audit reports, incident reports, complaints and other information to assess how the systems of legislative compliance can be improved.
- i. Identify the costs associated with new legislative requirements and determine future policy, resource and or workload/skills implications.

Council has a system in place (Legislative Compliance Procedure) to ensure that when legislation changes, steps are taken to ensure that actions comply with the amended legislation.

2 Roles and Responsibilities

Position	Responsibilities
General Manager or Delegated Authority	Approves the legislative Compliance Framework Review and approve Compliance Report.
Governance Officer	Administration of the Legislative Compliance Database Provide Compliance report to the General Manager Maintains the Compliance Register through Pulse Seek legislative compliance assurance from responsible officers identified in the Compliance Register.
Elected Members and Committee Members	Have a responsibility to be aware of and abide by the legislation applicable to their role.
ARIC	Provides independent advice to the General Manager about the adequacy of the Framework Reviews the Compliance Report and independently monitors remedial action that has been taken or is proposed on any non-compliance issues.
Leadership Team	Ensure Compliance with applicable legislation. Ensure employees are aware of their obligations in adhering to internal control systems. Advise Governance Officer of any new legislation relating to their department/service area operations. Respond to any request for information from the Governance Officer on compliance with legislation.
People & Culture	In conjunction with Governance Officer, provide staff training and awareness through induction and compliance learning modules.

Employees	<p>Adhere to Council policies, procedures, and internal control systems.</p> <p>Report any compliance concerns, issues and failures as outlined in the Code of Conduct for Council staff.</p>
-----------	---

3 Risk Management

Gwydir Shire Council recognises that there is potential for risk in many aspects of its operations. It is important to consider not only adverse consequences but also consider the potential opportunities or benefits that can be achieved by risk management. Effective management of risk is integral to good management and business practice.

Risk management is a critical component of governance arrangements and must be integrated into Council's governance, planning (including business planning, business continuity and project planning) and reporting framework.

Inadequate risk management can lead to:

- Council's inability to achieve its objectives.
- Financial loss.
- Poor decision making and lack of quality outcomes.
- Employee and customer health and safety issues.
- Opportunities not realised.

Any breaches of this Framework will be referred to the General Manager for appropriate action.

4 Legislative Compliance Procedure

4.1 Purpose

To support the above Legislative Compliance Policy.

This policy applies to all council officials, including councillors, employees and delegates, including volunteers, consultants, contractors any other service provider involved in exercising a Council function.

4.2 Procedure

4.2.1 Identifying Current, New or Amended Legislation

Council can access up to date electronic versions of legislation through the official New South Wales Government legislation website www.legislation.nsw.gov.au, it also relies on Circulars issued by the Office of Local Government NSW and individual governing bodies to advise of any legislative changes and reporting requirements. Some of these governing bodies include NSW Department of Planning, Industry and Environment, Local Government NSW and NSW Transport

Council may also identify new or amended legislation by using the following means:

a) **NSW Government Gazette:**

The NSW Government Gazette publishes all new or amended legislation applicable to New South Wales. The Gazette, published each Friday, includes new or amended legislation applicable to Council and can be accessed at www.legislation.nsw.gov.au/gazette.

b) **Special Interest Groups and Networking**

Council is involved in a number of Local Government networking and alliance groups. These special interest groups meet periodically to discuss matters which include legislative changes. Staff are encouraged to participate in relevant forums to keep informed of industry developments.

The officer responsible for the relevant legislation within their department/service area will:

- a) Acknowledge updates
- b) Maintain information regarding how Council addresses the responsibilities of the legislation, i.e. relevant policy, procedure, reporting requirements.

4.2.2 Obtaining Advice on Legislative Provisions

Council shall obtain advice on matters of legislation and compliance where this is deemed necessary. Contact can be made with the following organisations for advice:

- Local Government NSW
- Office of Local Government
- Legal service provider- with prior approval from the General Manager or Delegated Authority.

4.2.3 Informing Council of Legislative Change

If necessary the General Manager or a delegated officer will submit a report to Council on new or amended legislation detailing its impact on Council's activities or circulate appropriate relevant communications.

4.2.4 Reporting of Non-Compliance

All instances of non-compliance shall be reported immediately to the relevant Manager/Supervisor. The Manager/Supervisor shall determine the appropriate response and, if necessary, report the matter to the relevant Director.

4.2.5 Review of Incidents and Complaints Regarding Non-Compliance

Council shall review all incidents and complaints in accordance with its relevant incident and complaint handling policies and procedures. Such reviews and investigations will assess compliance with legislation, standards and policies and procedures that are applicable and referred to the General Manager or delegated authority for review and determination.

The General Manager may investigate any reports of significant non-compliance and, if necessary, report the non-compliance to the Council and/or the Office of Local Government. The General Manager will also take the necessary steps to improve compliance systems.

4.2.6 Audit on Legislative Compliance

Legislative compliance is included in Council's internal audit function. This internal audit function is currently undertaken by the Audit, Risk and Improvement Committee (ARIC).

A register of Legislative Compliance can be produced from the Legislative Compliance Database at the request of the ARIC for review and audit.

5 Related Documents

Council's Legislative Compliance Database – currently Corporate Planning and Reporting via Pulse platform.

Delegations Database

Complaint Handling Policy

Grievance Procedure

Code of Conduct

6 Related Legislation

Local Government Act, 1993

Local Government (General) Regulation, 2005

Australian Standard AS3806-2006: Compliance programs

7 Revision Record

Date	Version	Revision details	Officer	Next Review
23/4/2024	1	Initial Document	Governance Officer	2026

9.8 Audit, Risk and Improvement Committee (ARIC) Minutes

File Reference: NA

Delivery Program

Goal: 5. Organisational management

Outcome: 5.1 Corporate management

Strategy: 5.1.1 Financial Management and accountability systems

Author: General Manager

STAFF DISCLOSURE OF INTEREST Nil

IN BRIEF/SUMMARY RECOMMENDATION

This report is to note the Minutes of the ARIC Meeting held on 22nd April 2024 and to adopt various recommendations coming from the ARIC discussion.

TABLED ITEMS The ARIC Minutes from the meeting held on 22nd April 2024.

BACKGROUND

Gwydir Shire formed its initial Internal Audit Committee on 26th July 2018 where the Charter was only mentioned in passing but not formally adopted.

The following policies are recommended for adoption by the ARIC Meeting:

IT Disaster Recovery Plan;
Business Continuity Plan; and;
Fraud and Corruption Prevention Policy

ARIC RECOMMENDATIONS

THAT the attached Audit, Risk and Improvement Committee Charter is adopted.

FURTHER that the following policies are recommended for adoption:

**IT Disaster Recovery Plan;
Business Continuity Plan;
Fraud and Corruption Prevention Policy; and;
Fraud Control Plan**

FURTHER that the tabled ARIC Minutes from its 22nd April Meeting are accepted noting the following resolutions in particular:

Service Reviews

FURTHER that it is recommended that the Section 355 Committees be on the next Service Review List.

Child Safe Organisation Update

THAT the update be received noting that most of the policies have been adopted, the training is being rolled out and that the impact on the Council's operations are better understood and not as severe as first thought.

Draft 2024-2025 Budget

FURTHER that the Council continue to look for areas of savings to ensure the Council's ongoing financial sustainability.

ATTACHMENTS

1. ARIC Charter [9.8.1 - 4 pages]
2. IT Disaster Recovery Plan - April 2024 [9.8.2 - 16 pages]
3. Business Continuity Plan - 2024 [9.8.3 - 36 pages]
4. Fraud and Corruption Prevention Policy [9.8.4 - 10 pages]
5. GSC - Fraud Control Plan - Draft v 1 [9.8.5 - 23 pages]

COUNCIL RESOLUTION:

THAT the attached Audit, Risk and Improvement Committee Charter is adopted.

FURTHER that the following policies are recommended for adoption:

**IT Disaster Recovery Plan;
Business Continuity Plan;
Fraud and Corruption Prevention Policy; and;
Fraud Control Plan**

FURTHER that the tabled ARIC Minutes from its 22nd April Meeting are accepted noting the following resolutions in particular:

Service Reviews

FURTHER that it is recommended that the Section 355 Committees be on the next Service Review List.

Child Safe Organisation Update

THAT the update be received noting that most of the policies have been adopted, the training is being rolled out and that the impact on the Council's operations are better understood and not as severe as first thought.

Draft 2024-2025 Budget

FURTHER that the Council continue to look for areas of savings to ensure the Council's ongoing financial sustainability.

(Moved Cr Mulligan, Seconded Cr Galvin)

CARRIED

For: Cr J Coulton, Cr Egan, Cr D Coulton, Cr Galvin, Cr Matthews, Cr Moore, Cr Mulligan and Cr Smith

Against: Nil

Audit Committee Charter

Purpose

To facilitate the operation of the audit committee, the General Manager has responsibility to provide secretariat services and officer advice in respect of matters before the audit committee.

Authority

The audit committee has the responsibility for advising the elected Gwydir Shire Council on:

- seeking resolution on any disagreements between management and the external auditors on financial reporting
- reviewing all auditing, planning and outcomes
- seeking any information it requires from Gwydir's elected members, and Gwydir's staff via the General Manager and external parties
- formally meeting with Gwydir's staff, internal and external auditors as necessary.

Composition

- The audit committee will consist of at least three members, the majority of whom must be independent.
- The elected Council will appoint audit committee members and the audit committee chair.
- The chair of the audit committee must be independent.
- One audit committee member should be financially literate.
- The General Manager, finance and other staff are extended a standing invitation to attend meetings and participate in discussions of particular (possibly standard) agenda items. However the audit committee retains the right to exclude the mayor of the Council (if not a member of the audit committee), General Manager, finance and other staff from the meetings as and when this is considered necessary.
- Internal and external audit representatives are extended a standing invitation to attend relevant parts of each meeting. Where necessary the chair might decide that they should not attend for certain agenda items or that the audit committee will meet them without representatives of management in attendance. The audit committee may meet on occasion with each of the external and internal auditors without the presence of management.

Meetings

- The audit committee will meet at least four times a year, with authority to convene additional meetings, as circumstances require.
- All audit committee members are expected to attend each meeting, in person or through teleconference or video conference.

- The General Manager will facilitate the meetings of the audit committee and invite members of management, auditors or others to attend meetings to provide pertinent information, as necessary.
- Meeting agendas will be prepared and provided at least one week in advance to members, along with appropriate briefing materials.
- Minutes will be prepared.

Responsibilities

The audit committee will carry out the following responsibilities:

Financial Report

- Review significant accounting and reporting issues, including complex or unusual transactions and highly judgemental areas, and recent accounting, professional and regulatory pronouncements and legislative changes, and understand their effect on the financial report.
- Review with management and the external auditors the results of the audit, including any difficulties encountered.
- Review the annual financial report, and consider whether it is complete, consistent with information known to audit committee members, and reflects appropriate accounting principles.
- Review with management and the external auditors all matters required to be communicated to the audit committee under the Australian Auditing Standards.

Internal control

Develop, for Council's approval, a rolling 4 year internal audit program to review and improve the Council's internal controls over financial reporting, and obtain reports on significant findings and recommendations, together with management's responses.

Risk management

- Monitor the systems and process via the organisation's risk profile to ensure that material operational risks to Gwydir Shire are dealt with appropriately.
- Monitor the process of review of Gwydir Shire's risk profile.
- Consider the adequacy of actions taken to ensure that the material business risks have been dealt with in a timely manner to mitigate exposures to Gwydir Shire.

Business continuity

Monitor processes and practices of Gwydir Shire to ensure for effective business continuity.

External audit

- Note the external auditor's proposed audit scope and approach, including any reliance on the adopted internal audit activity.

- Provide an opportunity for the audit committee to meet with the external auditors, to discuss any matters that the audit committee or the external auditors believe should be discussed privately.

Compliance

- Review the systems and processes to monitor effectiveness of the system for monitoring compliance with legislation and regulations and the results of management's investigation and follow-up (including disciplinary action) of any instances of non-compliance.
- Keep informed of the findings of any examinations by regulatory agencies, and any audit (internal or external) observations and monitor management's response to these findings.
- Obtain regular updates from management about compliance matters.

Reporting responsibilities

- Report regularly and directly to the elected Council about audit committee activities, issues, and related recommendations through circulation of minutes and annual report. Additional updates may be appropriate should issues of concern arise.
- Monitor that open communication between the internal auditor, the external auditors, and the organisation occurs.
- Report annually in the Council's Annual Report to stakeholders, describing the audit committee's composition, responsibilities and how they were discharged.
- Consider the findings and recommendations of any relevant external Performance Audits that may be undertaken of Gwydir Shire Council.

Other responsibilities

- Perform other activities related to this charter as requested by the Council.
- Review and assess the adequacy of the audit committee charter annually, requesting the elected Council's approval for proposed changes, and ensure appropriate disclosure as might be required by legislation or regulation.
- Confirm annually that all responsibilities outlined in this charter have been carried out.
- Evaluate the audit committee's performance annually.

Frequency of meetings

A regular schedule of meetings should be designed to fulfil the audit committee's terms of reference. While the number and duration of audit committee meetings will largely depend on the size and complexity of the audit committee's responsibilities, it is common for the following to occur:

- As a guide the audit committee meets at least four times each year. There may also be a special meeting to consider the annual financial report. The frequency of meetings should be sufficient to enable the audit committee to effectively discharge its responsibilities.

- Meetings are arranged (for example, twelve months in advance) so that, where possible, all audit committee members can attend.
- The audit committee chair may convene a special meeting at his or her discretion or upon the request of Gwydir Shire, an audit committee member, senior management or the external or, if appointed, the internal auditor.



Gwydir Shire Council
**Draft IT Disaster Recovery
Plan**

Department: Information Services

Responsible Manager: Business Improvement & IT Manager

Date Adopted:

File Ref: 24/6946

Version No: 1.0

Next Review: April 2025

Pages: 16

Table Of Contents

1. Overview	4
1.1 Purpose	4
1.2 Objectives	4
1.3 Scope	4
2. Staff Responsibilities	5
3. Recovery Strategy	6
3.1 Assessment of Damage and Impact	6
3.2 Communication	6
3.3 Infrastructure Restoration	6
3.4 Restoration of Data	7
3.5 Return to Normal Operations	7
3.6 Post-Recovery Review	7
4. Backup and Restoration Strategy	8
4.1 Backup Software	8
4.2 On-site Backups	9
4.3 Cross-site Backups	9
4.4 Cloud Backups	10
4.5 Agent Backups	10
4.6 Backup Restoration Procedure	11
5. Recovery Procedures	12
5.1 Bingara Server Room Outage	12
5.2 Warialda Server Room Outage	14
5.3 Outage of Both Server Rooms	15
5.4 Small Site Recovery	15
5.5 Supplier Details	16
6. Monitoring and Review	16
7. Related Documents	16

Abbreviations and Definitions

Term	Definition	Abbrev
Business Continuity	The uninterrupted availability of all key resources supporting essential business functions.	BC
Business Continuity Plan	A collection of procedures and information that is developed, compiled, and maintained in readiness for use in the event of an emergency or disaster.	BCP
Continuity Management Team	The Continuity Management Team, upon advice from the CMT Director, will assess the interruption to business services including damage to the building, assets, infrastructure, services and records. The team will work to control and coordinate recovery and will make recommendations to the CMT Director.	CMT
Disaster Recovery	Disaster Recovery is a set of strategies, procedures, and technologies aimed at mitigating the impact of unexpected disruptions or disasters on an organisation's IT infrastructure, systems, applications, and data.	DR
Information Technology	Information technology refers to the infrastructure, systems, and processes that enable the storage, retrieval, processing, and communication of data critical to the operations of the business.	IT

Distribution List

The following table provides a list of all locations supplied with a copy of the Gwydir Shire Council Business Continuity Plan.

Name	Location
Bingara Customer Service	72 Maitland Street, Bingara, NSW, 2404 (Safe)
Warialda Customer Service	54 Hope Street, Warialda, NSW, 2402 (Strong Room)
Information Services Office	48 Maitland Street, Bingara, NSW, 2404
Warialda Records Room	38 Hope Street, Warialda, NSW, 2402
Content Manager	24/6946

1. Overview

1.1 Purpose

In today's interconnected and technology-driven environment, the reliance on Information Technology (IT) systems within government institutions, such as local councils in New South Wales, is paramount. Recognising the critical role that information technology infrastructure plays in delivering essential services to our community, it is imperative to establish a robust IT Disaster Recovery Plan to ensure the continuity of operations in the face of unforeseen disruptions or disasters.

Council recognises the importance of maintain uninterrupted access to vital IT systems and data to fulfill our mission to service the residents and stakeholders of Gwydir Shire. As part of our commitment to preparedness and resilience, this Disaster Recovery Plan has been developed to provide a comprehensive framework for responding to a recovering from IT related disasters effectively.

1.2 Objectives

The primary objective of this IT Disaster Recovery Plan is to:

- Ensure business continuity;
- Protect data integrity and availability;
- Mitigate financial and reputable impact;
- Enhance response capabilities; and
- Facilitate compliance and governance.

1.3 Scope

The IT Disaster Recovery Plan should be read in conjunction with the Business Continuity Plan (BCP) as it is a subset of this document. It encompasses all critical systems, applications, and infrastructure within Council. This plan applies to all department and functions that rely on IT resources to carry out their operations efficiently and effectively.

The IT Disaster Recovery Plan is designed to address various potential disasters that result in the loss or partial loss of Council sites. It does not address the response in the result of a cyber incident or data breach. For the procedures for these scenarios, refer to the Cyber Incident Response Plan and the Data Breach Policy, respectively.

The applicability of this IT Disaster Recovery Plan extends to all Council departments, employees, contractors, vendors, and stakeholders involved in IT operations and disaster recovery efforts. It is imperative that all applicable personnel within the council understand their roles and responsibilities as outlined in this plan and are prepared to execute them in the event of an IT disaster.

2. Staff Responsibilities

This section serves as an extension of the established Continuity Management Team (CMT) outlined in the Business Continuity Plan. The roles defined here align with existing roles, with additional responsibilities specifically tailored for the recovery of IT systems.

IT Manager:

Non-Activation Period

- Having access to electronic current copies of the IT Disaster Recovery Plan.
- Reviewing, updating, and testing the plan. The required frequency is in Section 6, Monitoring and Review, of this document.
- Assessing and escalating incidents to the CMT as necessary.

Activation Period

- Implementing and leading the IT Disaster Recovery Plan.
- Participating in business continuity management and recovery operations as required.
- Participating in post-event reviews as required.

IT Staff:

Non-Activation Period

- Maintain Council's IT infrastructure, including servers, networks, and storage systems.
- Implement technical controls and safeguards to protect critical systems and data.
- Participate in DR planning, testing, and recovery efforts as needed.

Activation Period

- Participating in business continuity management and recovery operations as required.
- Participating in post-event reviews as required.

Staff are responsible for:

Non-Activation Period

- Participating in training and testing as required.
- Reporting any incident information to the IT Manager for assessment.

Activation Period

- Participating in continuity management or recovery operations as required.
- Participating in post-event reviews as required.

3. Recovery Strategy

This section outlines the systematic steps we will undertake to restore our IT systems and operations in the event of a disruption or disaster. Site-specific scenarios are covered in section 5.

Our primary objective is to minimise downtime and data loss, ensuring the continuity of business operations while maintaining the highest level of security and integrity. The recovery procedure is designed to be flexible and adaptable, capable of responding to a variety of potential disaster scenarios. This procedure is not a one-size-fits-all solution, but rather a framework that guides recovery efforts.

3.1 Assessment of Damage and Impact

Immediately after a disaster, the IT team will conduct an initial damage assessment. This involves identifying which IT systems and data have been affected, and the nature and extent of the damage. This could range from minor issues that can be quickly resolved, to major damages that could potentially lead to significant downtime. Based on the assessment, it will be decided whether to activate the DR plan.

Following the initial assessment and the DR plan is invoked, an impact analysis will be performed. This involves determining the potential business impact of the identified damages. This will include factors to consider such as the criticality of the affected systems, the extent of data loss, the potential financial implications, and the impact on our customers and stakeholders.

Based on the impact analysis, recovery efforts will be prioritised. Systems and data that are most critical to business operations will be given the highest priority. This ensures that the most important operations are restored first, minimising the impact on Council.

All findings from the damage assessment and impact analysis will be documented. This includes the details of the damage, the estimated recovery time, the potential business impact, and the recovery priorities. This documentation will serve as a guide for the recovery efforts and will be crucial for any post-disaster reviews.

3.2 Communication

Communication is a crucial aspect of any disaster recovery process. It ensures that all relevant parties are informed about the status of the recovery process, which helps to manage expectations and reduce uncertainty.

All communication during the disaster recovery process should follow the procedures defined in the Business Continuity Plan (BCP). The BCP outlines who should communicate, what information should be communicated, and how it should be communicated.

Please refer to the BCP for detailed communication procedures, including templates for communication, designated spokespersons, and protocols for different types of communication (internal, external, media, etc.).

3.3 Infrastructure Restoration

This step involves bringing the IT infrastructure back to its operational state. Before data can be restored, there needs to be appropriate infrastructure available to restore to. The extent of the damage needs to be assessed. This involves identifying which components of the infrastructure have been affected and the severity of the damage.

The actual process of infrastructure restoration will depend on the nature and extent of the damage. It may involve repairing or replacing damaged hardware, restoring network connectivity, or rebuilding servers. In some cases, consideration for using alternative infrastructure, such as cloud services or a secondary site may be required.

Once the infrastructure has been restored, it is important to conduct thorough testing to ensure it is functioning correctly.

3.4 Restoration of Data

This step is vital as it involves bringing back the critical business data to its pre-disaster state. The data recovery plan is based on the backups in place. Council has a robust backup strategy that includes regular backups of all critical data. These backups are stored in on-site, across sites, and off-site in cloud storage to ensure their availability in the event of a disaster.

Based on the impact analysis, data restoration will be scheduled by priority. Data that is most critical to our business operations will be restored first. This ensures that we can resume the most important operations as quickly as possible.

The actual process of data restoration will depend on the nature and extent of the damage. In some cases, it may be as simple as restoring from the most recent backup. In the most extreme cases, it may involve working with a third-party service to recover data from damaged devices.

Once data has been restored, it's important to verify its integrity. The IT team will check the restored data against its original state to ensure its completeness and accuracy. Any discrepancies will be noted and addressed. Communication with users and relevant stakeholders from the IT team will be conducted to facilitate the transition to business continuity operations.

3.5 Return to Normal Operations

The next step in the recovery procedure is the return to normal operations. This step signifies the end of the recovery process and the resumption of normal business operations. It is the return to operations as they were pre-disaster, or what will be determined as the new business as usual.

Returning to normal operations is often a phased process. It starts by restoring the most critical functions, followed by less critical ones. This approach helps to minimise disruption and ensures that the most important aspects of Council are up and running as quickly as possible.

3.6 Post-Recovery Review

The final step in the recovery procedure is the post-recovery review. This step involves analysing the response to the disaster and identifying areas for improvement. This involves examining each step of the process, from the initial response to the return to normal operations. The IT team will identify what went well, what didn't go as planned, and why. By identifying these lessons, it can improve the response to future disasters.

Based on the lessons learned, the DR plan will be updated. This could involve revising recovery strategies, improving communication procedures, or enhancing backup and restoration processes. The goal is to make our DR plan more effective and efficient. Any changes to the DR plan will be communicated to all relevant staff, and additional training will be provided if necessary.

4. Backup and Restoration Strategy

Data is one of the most valuable assets for Council. However, data is constantly at risk from threats such as hardware failures, software bugs, cyber-attacks, human error, and natural disasters.

A robust backup strategy is therefore not just an optional extra, but a fundamental requirement. This section outlines how data is backed up, where backups are stored, and how data can be restored in the event of a loss.

It is important to note that in the scenario of a total site loss, there could be a potential loss of up to one day’s worth of data. This is due to the constraints of the backup schedule and the limitations of the network resources.

Retention policies noted below are subject to change (increase and decrease) based on the availability of storage as data fluctuates.

Below is a basic diagram of the backup copy strategy.

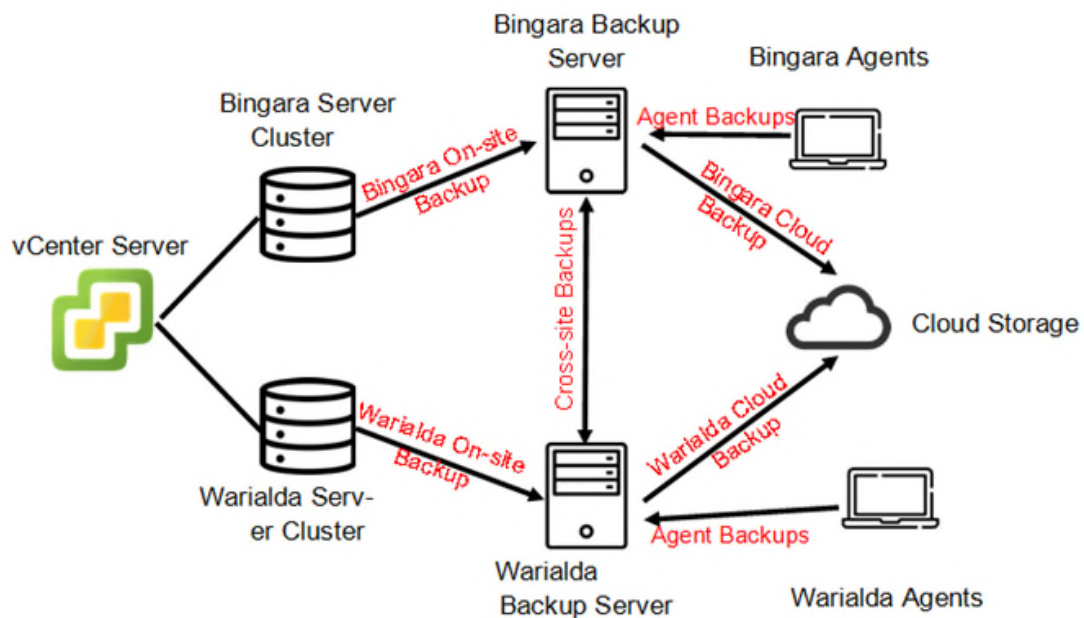

4.1 Backup Software

Council utilises Veeam as its chosen backup software, a decision driven by Veeam’s robust and reliable data protection capabilities. Council implements the 3-2-1 rule for backing up data as designed for best practice. Backups are held in three locations: onsite (at each Bingara and Warialda office), copied to across each site (Bingara and Warialda), and in the cloud. Onsite backups provide quick access for data restoration, while across-site backups add an extra layer of protection against site-specific incidents. Cloud backups offer a geographically independent safeguard, ensuring data can be recovered even in the event of a major disaster affecting physical locations. This comprehensive approach ensures that the Council’s data is well-protected and always available when needed.

The Council also utilises Veeam for its Microsoft 365 backups, ensuring that essential data within the Microsoft 365 suite is effectively protected. These backups are stored at our Warialda site, providing a reliable and accessible solution for data restoration. This strategy not only safeguards against data loss within Microsoft 365 applications but also ensures that the data can be swiftly restored to maintain business continuity. By leveraging Veeam's robust backup capabilities in conjunction with strategic storage at the Warialda site, the Council ensures comprehensive protection for its Microsoft 365 data.

4.2 On-site Backups

On-site backups are completed for both the Bingara and Warialda office servers. Each site has a dedicated backup server to store data.

Schedule: Backups are scheduled to run daily. This ensures that the most recent data is always protected.

Backup Job Configuration: Each backup job is configured to target the specific server cluster for each site. This includes virtual machines, databases, and files. There are no exclusions in this job. They are incremental, with an active full backup completed on each Saturday. This is to ensure that if a backup chain becomes corrupt, it won't propagate too far into the past, whilst maintaining performance.

On-Site Storage: The backups are stored on-site on the dedicated backup storage device. This allows for quick access and restoration of data when needed.

Retention Policy: A retention policy of 40 days is set for the backups. This means that each backup is kept for 40 days before it is automatically deleted by Veeam. This helps to manage storage space and ensures that the most recent and relevant backups are always available.

Backup Verification: After each backup job is completed, Veeam's SureBackup feature is used to verify a subset of 5 randomised virtual machines in the backup. This ensures that the backup was successful, and that the data can be restored.

Backup Monitoring: The status of the backup jobs is monitored regularly. Alerts are set up to notify the IT team if a backup job fails or if there are issues with the backup storage device.

4.3 Cross-site Backups

Cross-site backups are completed for both the Bingara and Warialda office servers, copying the on-site backup job to the other office. Each site keeps a copy of the other office's data on their dedicated backup server.

Schedule: Backups are scheduled to run continuously, copying once the on-site job is complete. This ensures that the most recent data is always protected.

Backup Job Configuration: Each backup job is configured to copy the on-site job, which is a like-for-like of that job. There are no exclusions in this job.

Cross-Site Storage: The backups are stored the alternate site on the dedicated backup storage device. This allows for quick access and restoration of data when needed, as well as redundancy if the primary site is no longer available.

Retention Policy: A retention policy of 14 restore points is set for the backups. This means that the last 14 backup jobs are kept before it is automatically deleted by Veeam. This helps to manage storage space and ensures that the most recent and relevant backups are always available.

Backup Monitoring: The status of the backup jobs is monitored regularly. Alerts are set up to notify the IT team if a backup job fails or if there are issues with the backup storage device.

4.4 Cloud Backups

Cloud backups are completed for both the Bingara and Warialda office servers. Each site has critical data sent to the cloud provider's (SaberVox Attura) repository.

Schedule: Backups are scheduled to run every 12 hours. This ensures that the most recent data is always protected.

Backup Job Configuration: Each backup job is configured to target the specific server cluster for each site. This includes virtual machines, databases, and files. There are exclusions in the job that omits servers that are not critical to operations and would be acceptable to use or rebuild in the event of an emergency. They are forever incremental and are separate from the on-site backup. This is to ensure that if a backup chain becomes corrupt on-site, it won't affect the cloud backup. The data is encrypted with the recovery password in the custody of the IT team.

Cloud Storage: The backups are stored off-site on a data centre located in NSW. This is for last resort situations where both sites have become unavailable, as it is the slowest method for access and restoration of data.

Retention Policy: A retention policy of 20 restore points is set for the backups. This means that the last 20 backup jobs are kept before it is automatically deleted by Veeam. This helps to manage storage space and costs, whilst ensuring that the most recent and relevant backups are always available.

Backup Monitoring: The status of the backup jobs is monitored regularly. Alerts are set up to notify the IT team if a backup job fails or if there are issues with the backup storage device.

4.5 Agent Backups

Agent backups are tasks that create a snapshot of a laptop or PC, which holds crucial data not typically stored or secured by our servers or cloud services. Each location collects agents within its geographical proximity. Only a handful of these remain. They utilize the Veeam Agent installed on each device and perform backups to the dedicated backup server at each respective site.

Schedule: Backups are scheduled to run daily. However, as some machines are not on all the time like the servers, there may be missed days. If a backup is missed, it will run at next availability.

Backup Job Configuration: Each backup job is configured to target the machine that it runs from, taking a copy of the PC in its entirety.

Storage: The backups are stored on one of the dedicated backup servers that it is geographically closest to. This will ensure that if there is a site outage, that there is a copy off-premises that can be used to restore the machine.

Retention Policy: A retention policy of 15 restore points is set for the backups. This means that the last 15 backup jobs are kept before it is automatically deleted by Veeam. This helps to manage storage space, whilst ensuring that the most recent and relevant backups are always available.

Backup Monitoring: The status of the backup jobs is monitored regularly. Alerts are set up to notify the IT team if a backup job fails or if there are issues with the backup storage device.

4.6 Backup Restoration Procedure

The method of data restoration varies based on the extent of damage to the equipment and site. If the server infrastructure remains operational, relocating the equipment to another site and restoring network connectivity suffices.

However, if the server infrastructure is non-functional, data restoration via Veeam becomes necessary. The prioritisation of the source for restoration depends on availability, following this preference order:

1. On-site backup
2. Backup copy in Warialda
3. Cloud backup

The following steps are required to carry out restoration.

Step 1 – Initiate Restoration Process: If new infrastructure equipment was required, ensure it is added as needed to vCenter and to the inventory of Veeam. This will allow the new infrastructure to communicate and restore with Veeam. Then begin the restoration process by accessing the backup repository and selecting the appropriate backup point from which to restore data.

Step 2 – Selection of Backup and Infrastructure: Choose the specific backup point that contains the desired data to be restored. Consider factors such as the timestamp of the backup, the state of the data at that point in time, and any dependencies with other systems or applications. Determine the target infrastructure where the restored data will reside. This will be the vCenter instance that the servers are managed by.

Step 3 – Configuration and Verify Restoration Options: Configure restoration settings according to the requirements of the data and the target environment. This may include options for restoring entire virtual machines, individual files or folders, application-specific data, or database records. Verify the restoration settings to ensure accuracy and completeness. Double-check parameters such as destination paths, overwrite options, and any additional configuration settings to avoid unintended consequences.

Step 4 – Initiation of Restoration Job: Once all settings are confirmed, initiate the restoration job and monitor the progress of the restoration process to ensure it proceeds smoothly and within the expected timeframe.

Step 5 – Error Handling and Troubleshooting: In case of any errors or issues encountered during the restoration process, troubleshoot promptly to identify the root cause, and implement corrective actions. Utilise Veeam's logging and reporting features to diagnose problems and resolve them efficiently.

Step 6 – Completion Confirmation: Upon successful completion of the restoration job, verify that the restored data is accessible and functional. Perform basic validation checks to ensure that the data integrity is preserved and that it meets the organization's requirements for recovery.

Step 7 – Documentation: Document details of the restoration process, including the selected backup point, restoration settings, any challenges encountered, and the outcome of the restoration job. This documentation serves as a record of the recovery efforts and provides valuable insights for future reference.

5. Recovery Procedures

In the event of a complete outage, our ability to recover and restore operations quickly and effectively is paramount. This section is dedicated to outlining our approach to recovery in the context of the specific sites that are critical to our IT operations.

5.1 Bingara Server Room Outage

Our primary site, which accommodates the bulk of our essential IT infrastructure and servers, is currently situated in the Bingara server room. This room is located at the rear of the Bingara Library, at 29 Maitland Street. Due to the demolition of the main Bingara Council office, the site is presently in a state of “business continuity”. Plans are in place to relocate it to a new building once construction is completed. Despite these circumstances, it remains crucial to maintain a contingency plan for potential outages at this site.

Network Diagram

Below is a high-level network diagram to assist in the recovery of IT operations.

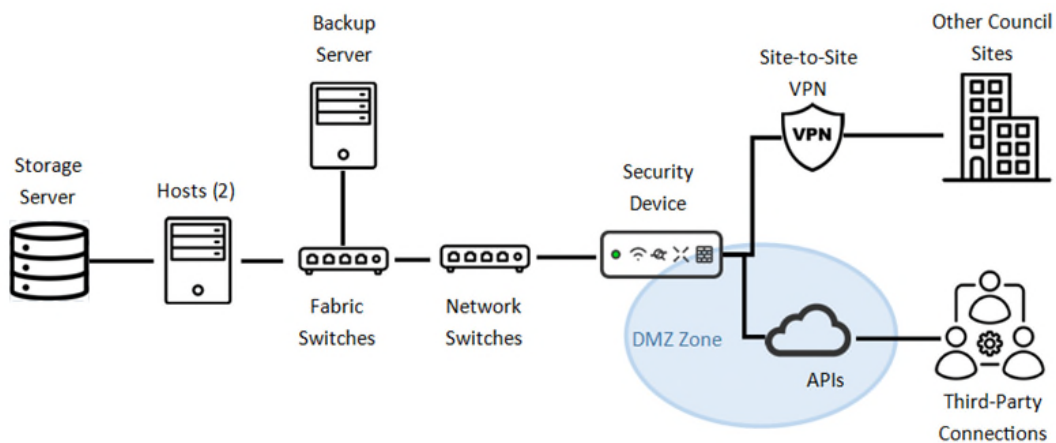

Alternative Sites

Primary Option: Warialda Office

If available as a recovery site, the initial restoration should be targeted to occur at the Warialda Office. Utilising the existing server room infrastructure located at this site will minimise downtime in comparison to alternative locations. Further, the internet capacity at the Warialda Office is sufficient for the data requirements of day-to-day operations and for backups. However, the server hardware might not have the capacity to operate all the services currently covered by Bingara. Therefore, prioritisation of restoration tasks may be necessary to ensure the most critical services are restored first.

Secondary Option: The Living Classroom

Should Warialda be unavailable, or if the Bingara Office is expected to be non-operational for an extended period necessitating a secondary site (additional to Warialda for backups), the Living Classroom could be considered. This is attributed to its internet capability, as it has Fibre to the Premise (FTTP). However, procurement of equipment would be required due to the absence of existing server infrastructure at this location.

Equipment Procurement

A list of suppliers is available in section 5.5.

A list of equipment presently in use at the Bingara Office is provided below. This list can serve as a reference for procuring identical hardware if replacements become necessary, or if additional equipment is needed to accommodate increased site demands.

Equipment Type	Model	Quantity	Supplier
Host (VMware ESXi, 7.0.3)	Dell PowerEdge R650xs Intel® Xeon® Silver 4314 CPU @ 2.40GHz CPU Capacity - 38.3GHz Memory Capacity – 256GB Logical Processors: 32 NICS: 4	2	Dell
Host Storage	Dell PowerVault Manager ME5012 Storage Capacity – 28TB	1	Dell
Backup Server	Dell EMC NX3240 Intel® Xeon® Silver 4214 CPU @ 2.20GHz (2 Processors) Memory Capacity – 64GB Windows Storage Server 2016 Standard Storage Capacity – 112TB	1	Dell
Security Device	Cisco Meraki MX95	2	MWave
Switches	Ubiquiti US-48-500W	4	MWave
UPS (Backup Power)	APC Smart-UPS 2200	3	MWave

Data Restoration

See section 4.6 for data restoration procedure using Veeam.

Here are some considerations that are specific to the Bingara site that may assist with restoration:

- Ensuring continuity of our backup strategy is crucial, especially if the backup server in Bingara is no longer accessible. Ordering a new server and restoring it promptly is imperative to maintain backup operations and uphold redundancy levels.
- The site-to-site VPN for smaller sites uses the static IPs to establish connections. If the IP addresses at the Bingara site changes, this will need to be reconfigured at each of these sites.
- If the Bingara servers are restored in Warialda, or with different subnets, these will need to be reconfigured during the restoration procedure.

- If the Bingara servers are restored in Warialda, the procurement of additional hosts will be essential to be able to get all the infrastructure running again. However, priority equipment should be able to run on this network.
- If the Bingara servers are restored in Warialda, the Meraki devices in Warialda will have to be upgraded to MX95s at a minimum to have sufficient capacity once services are reestablished completely.
- The public APIs (internet facing) have DNS entries configured to point to the allocated IP addresses for these. This will need to be reconfigured if internet IP addresses change due to restoration.
- Third parties may use whitelisting to allow the API connection to their sites. They will need to be contacted with this information if required.
- For speed and reliability of restoration, if using the Warialda backup server, it may be quicker to physically move the backup server and establish on the new network temporarily.

5.2 Warialda Server Room Outage

Our primary site, which accommodates the bulk of our essential IT infrastructure and servers, is currently situated in the Warialda server room. This room is located at the rear of the Warialda office building, at 54 Hope Street.

Network Diagram

Below is a high-level network diagram to assist in the recovery of IT operations.

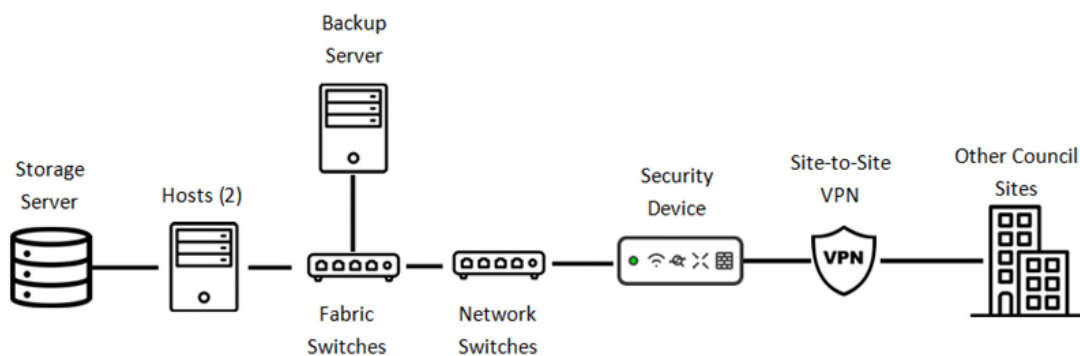

Alternative Sites

Primary Option: Bingara Office

If available as a recovery site, the initial restoration should be targeted to occur at the Bingara Office. Utilising the existing server room infrastructure located at this site will minimise downtime in comparison to alternative locations. Further, the internet and server capacity at the Bingara Office is sufficient for the data requirements of day-to-day operations and for backups.

Secondary Option: The Living Classroom

Should the Bingara office be unavailable, or if the Warialda Office is expected to be non-operational for an extended period necessitating a secondary site (additional to Bingara for backups), the Warialda Depot could be considered. This is attributed to geographical redundancy from Bingara.

The internet capability is currently poor though, as it only has (FTTN). It is useful for backups. However, procurement of equipment would be required due to the absence of existing server infrastructure at this location.

Otherwise, the Living Classroom would be sufficient, as outlined in the Bingara Office alternative sites.

Equipment Procurement

A list of suppliers is available in section 5.5.

Although it is not the list of equipment established in Warialda, the list of equipment for Bingara should be used as a guide as it is more up to date and capable. Refer to this list as a reference for procuring hardware replacements, or if additional equipment is needed to accommodate increased site demands.

Data Restoration

See section 4.6 for data restoration procedure using Veeam.

Here are some considerations that are specific to the Warialda site that may assist with restoration:

- Ensuring continuity of our backup strategy is crucial, especially if the backup server in Warialda is no longer accessible. Ordering a new server and restoring it promptly is imperative to maintain backup operations and uphold redundancy levels.
- The site-to-site VPN for smaller sites uses the static IPs to establish connections. If the IP addresses at the Warialda site changes, this will need to be reconfigured at each of these sites.
- If the Warialda servers are restored in Bingara, or with different subnets, these will need to be reconfigured during the restoration procedure.
- For speed and reliability of restoration, if using the Bingara backup server, it may be quicker to physically move the backup server and establish on the new network temporarily.

5.3 Outage of Both Server Rooms

If both server rooms become unavailable, selecting a site for permanent restoration becomes necessary, requiring complete provisioning of networking infrastructure. The Bingara site's equipment list should guide replacements to ensure adequacy. Though this entails longer downtime compared to an alternate site, Dell's priority delivery should expedite the process.

Alternatively, a cloud provider could host a cloud vCenter instance for quicker uptime by restoring cloud backups. Bandwidth limitations may slow this process.

Restoration procedures would align with those for the Bingara site in these scenarios.

5.4 Small Site Recovery

In the event of a smaller site becoming unavailable, alternate office locations are established in the Business Continuity Plan. Alternative locations are already enabled to work on Council's network and only replacement PCs and peripherals would be required.

5.5 Supplier Details

Below is a list of critical infrastructure providers that may need to be contacted quickly in an emergency.

Dell:

Ricky.Jamin@Dell.com

+61 2 9932 1559

MWave:

Sales

corporate@mwave.com.au

1300 727 446

Aussie Broadband:

support@aussiebroadband.com.au

1300 880 905

6. Monitoring and Review

Monitoring and review are an integral component of the disaster recovery process. The Council acknowledges this importance and pledges to conduct desktop scenarios annually to simulate outages. By engaging in such exercises, the IT team aims to enhance preparedness, identify areas for improvement, and validate the resilience of IT systems and processes.

7. Related Documents

Business Continuity Plan

Cyber Incident Response Plan

Data Breach Policy

Incident Response Plan



Gwydir Shire Council
**Draft Business Continuity
Plan**

Department: Risk & WHS

Responsible Manager: Risk Manager

Date Adopted:

File Ref: 24/5744

Version No: 1.0

Next Review: April 2025

Pages: 36

Table Of Contents

1. Overview	6
1.1 Purpose	6
1.2 Objectives	6
1.3 Scope	6
1.4 Use of the BCP	6
1.5 Assumptions	6
1.6 Limitations	7
1.7 Audience	7
1.8 Authority	7
1.9 Training and Communication	7
1.10 Validation and Testing	7
2. Methodology	8
3. Continuity Management Team	9
4. Staff Responsibilities	12
5. Declaration of a Business Continuity Event	14
5.1 Notification	14
5.2 Assessment	14
5.3 Declaration	14
5.4 Recovery Coordination Centre	14
5.5 Initial CMT Meeting	15
5.6 Authority	15
5.7 General Statement to the Media	15
5.8 Business Continuity Instructions (BCI)	16
BCI 1 Emergency Contacts – Internal	17
BCI 2 Emergency Contacts – External	18
BCI 3 CMT Initial Meeting Agenda	19
BCI 4 Media Release (Initial Holding Statement)	20
BCI 5 Media Enquiry Form	21
BCI 6 Staff Notification Email / Message	22
BCI 7 Business Continuity and Recovery Coordination Centre Options	23
BCI 8 Alternate Work Locations	24
6. Critical Function Sub Plans	26
6.1 Critical Function 1: Customer Service	26

6.2 Critical Function 2: Information Technology	28
6.3 Critical Function 3: Records	30
6.4 Critical Function 4: Payroll.....	32
6.5 Critical Function 5: Social Services	34
7. Monitoring and Review	36
8. Related Documents.....	36

Abbreviations and Definitions

Term	Definition	Abbrev
Business Continuity	The uninterrupted availability of all key resources supporting essential business functions.	BC
Business Continuity Plan	A collection of procedures and information that is developed, compiled, and maintained in readiness for use in the event of an emergency or disaster.	BCP
Business Continuity Management	Business Continuity Management provides for the availability of processes and resources to ensure the continued achievement of critical objectives.	BCM
Business Impact Analysis	A management level analysis, which identifies the impacts of function loss on the organisation. The BIA provides management with data upon which the base risk mitigation and continuity planning decisions.	BIA
Business Interruption Event	Any event, whether anticipated (i.e. public service strike) or unanticipated (i.e. blackout) which disrupts the normal course of business operations at an organisation location.	BIE
Continuity Management Team	The Continuity Management Team, upon advice from the CMT Director, will assess the interruption to business services including damage to the building, assets, infrastructure, services and records. The team will work to control and coordinate recovery and will make recommendations to the CMT Director.	CMT
Critical Function Sub Plan	A plan to guide a business activity that must be operative with a timeframe of any significant event that causes interruption to council core services.	CFSP
Information Technology	Information technology refers to the infrastructure, systems, and processes that enable the storage, retrieval, processing, and communication of data critical to the operations of the business.	IT
Maximum Acceptable Outage	The maximum period of time that Council can tolerate the loss of capability of a critical business function, process, asset or IT application.	MAO

Distribution List

The following table provides a list of all locations supplied with a copy of the Gwydir Shire Council Business Continuity Plan.

Name	Location
Bingara Customer Service	72 Maitland Street, Bingara, NSW, 2404 (Safe)
Warialda Customer Service	54 Hope Street, Warialda, NSW, 2402 (Strong Room)
Information Services Office	48 Maitland Street, Bingara, NSW, 2404
Warialda Records Room	38 Hope Street, Warialda, NSW, 2402
Content Manager	Ref 24/5744

1. Overview

1.1 Purpose

The Business Continuity Plan (BCP) serves as a foundational document outlining our organisation's preparedness and response strategies in the face of unexpected disruptions. Its primary objective is to ensure the uninterrupted delivery of critical services and operations amidst challenging circumstances. By establishing clear protocols and delineating responsibilities, the BCP aims to minimise downtime, safeguard valuable assets, and prioritise the well-being of our staff and community members.

Council recognises this plan, in isolation, does not build capability. It provides the approach to establishing those effective capabilities. This plan identifies the required facilities, technical infrastructure, key responsibilities, and processes that will be required to allow Council to respond and recover from a business interruption event.

1.2 Objectives

To enable Council and its employees (including contractors and volunteers) to:

- Ensure critical services vital for community well-being remain operational;
- Develop resumption plans based on criticality of functions;
- Build resilience within Council's operations;
- Identify and document roles and responsibilities for key positions;
- Minimise the impact of function loss on stakeholders and the community.

1.3 Scope

The objective of the plan is to ensure appropriate structures and protocols are in place to enable effective response to a business interruption event. The plan documents the processes and resources required by Council in the delivery of its critical business objectives.

In identifying business continuity risks, the focus is on building of resilience and response capabilities within business functions that have been identified as critical by the organisation.

The plan does not cover requirements associated with a workplace emergency (safety) situation. A separate workplace emergency plan is available.

1.4 Use of the BCP

This plan should be used in the event of a business interruption event that may impact the ability of Council to deliver business objectives. Managers and staff with responsibility for impacted areas of the business should use the plan and any relevant sub plans to ensure a consistent and agreed course of action is implemented.

1.5 Assumptions

The plan is intended to provide guidance to Council officers to assist continuity of service for critical functions, where those officers are not normally responsible for managing the specific function affected. Where the Council officer who is normally responsible for managing the specific function is available, this document will serve as a reference to reduce possibility of missing important actions.

1.6 Limitations

It is not the intent of this plan to develop Information Technology (IT) Disaster Recovery plans. It will, however, identify requirements for IT resources that support the delivery of business-critical functions. This information should then be used to inform the development of an IT specific plan.

1.7 Audience

The intended audience for the Gwydir Shire Council Business Continuity Plan is:

- Council
- Senior Leadership Group
- Critical Function Sub Plan Managers and Staff
- Non-Critical Function Action Plan Managers and Staff.

The plan is available to all employees via Council's intranet and is to be reviewed annually by the Senior Leadership Group and sub plan owners.

A list of staff and locations that the document has been distributed to directly is listed in the distribution section of this document.

1.8 Authority

This plan has been developed under the authority of the Senior Leadership Group. Prior to implementation the plan was reviewed and approved at the Senior Management Meeting. A standing authority is given to the sub plan owners by the Senior Leadership Group to implement the actions identified within those sub plans.

1.9 Training and Communication

A key objective is to increase the awareness within Council of potential business interruption events that could impact Council. The plan outlines the response/recovery protocols associated with such events. Training and communication will play a key role in achieving this objective.

It will be the responsibility of the various leaders to ensure that the requirements of the plan are communicated to all staff and that induction and training programs include reference to business continuity in the context of sound risk management practices.

Managers should be familiar with key deliverables detailed in the Critical Function Sub Plans and ensure staff are aware of roles and responsibilities in the event of a business interruption event.

1.10 Validation and Testing

Business Continuity Management (BCM) is a process, not an event. Once the plan has been prepared, commitment to a pre-planned, annual test plan and maintenance schedule is required by Council to ensure procedures remain viable into the future. The testing should include all aspects of the BCP, but not necessarily all in one year. Sub plans should be reviewed at least annually. Volatile information such as contact lists, or areas that are constantly undergoing changes, should be validated more frequently.

2. Methodology

Business continuity encompasses the identification and risk management of Council's business processes. It seeks to identify, assess control, and monitor Council's business functions. Broadly, the steps in developing the Business Continuity Plan include:

1. Identify and Assess Business Processes and Functions

Identify business processes and functions within each individual business unit. Once the functions are identified an analysis at a whole of organisational level is conducted to determine which functions are critical and require further planning to ensure the ability to respond in the face of a continuity interruption event.

2. Conduct the Business Impact Analysis (BIA)

The BIA is conducted on those functions identified as critical within the business process assessment. The BIA is intended to identify the impacts of the function loss on the business including penalties for non-delivery, functional interdependencies, organisational ownership, and it also looks at the resources currently required to support the functions and assesses the minimum level of resources required to continue the availability. Importantly the BIA is the tool that is used to determine the Maximum Acceptable Outage (MAO).

3. Critical Function Sub Plan (CFSP)

The CFSP identifies the agreed actions that a business process owner will undertake to manage the loss of the function through the emergency, continuity, and recovery phases. The sub plan identifies ownership, failure scenarios, criteria for invoking the plan, agreed courses of actions for emergency, continuity, and recovery.

4. Overarching Business Continuity Plan

The BCP identifies the responsibilities of key leaders, with particular emphasis on direction setting and effective and timely communication to stakeholders at an organisational level. It is important to recognise that this document provides a flexible framework in which the organisation can plan for disruption of its critical functions. It does not attempt to identify and plan for every contingency or outage that could occur. It provides a flexible framework for the process owners to identify, plan and develop redundancy for business processes.

5. Test and maintain the Business Continuity Plan

The BCP will be reviewed annually by the Senior Leadership Group, these actions are essential to ensure that it reflects the current practices of the organisation.

Testing of the critical function sub plans and overarching plans will provide management assurance that the plan(s) are effective. The testing regime is based on the following:

- Desktop/paper audit to ensure that the appropriate documents are available and understood.
- Structured "walk through" where a business interruption scenario is played out through a mock recovery, and a divisional or whole of organisation level. Frequency and actions to be undertaken are identified within the monitoring and review section of this document.

3. Continuity Management Team

This section outlines the key roles, duties, and decision-making authority of the designated team responsible for orchestrating and executing the organisation's business continuity strategies, guaranteeing a swift and effective response to any unforeseen disruptions.

The Business Continuity Team shall be comprised of the permanent members as per the responsibility statements below.

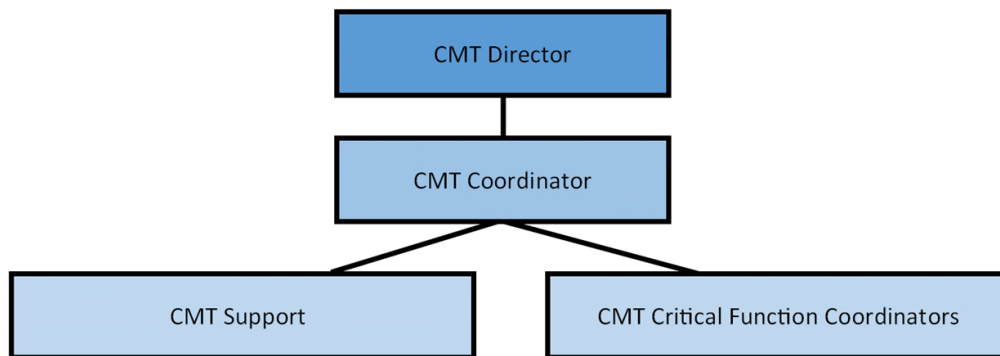

CMT Director	
Staff Position	General Manager
During absence this role will be assumed by	Acting General Manager
Position Statement	<p>The CMT Director is responsible for declaring a business continuity event and invoking the BCP. The CMT Director is required to oversee and manage all resumption activities.</p> <p>During a workplace emergency the Chief Warden has authority until the workplace emergency is resolved and control is returned to the General Manager or CMT Director if the BCP is to be activated.</p>
Responsibilities	<p>The CMT Director must make decisions as to the best strategy for business resumption based on information received by other CMT members. This strategy is then translated into an action plan by the supporting teams.</p> <p>Responsibilities include:</p> <ul style="list-style-type: none"> • Maintain working knowledge of BCP & relevant Critical Function Sub Plans. • Participate in monitor and review activities. • Participate in and ensure appropriate levels of training is undertaken. <p>On Activation:</p> <ul style="list-style-type: none"> • Activate the BCP. • Notifying and liaising with stakeholders. • Provide the focal point in communication to the staff, media and public.

	<ul style="list-style-type: none"> • Establishing and chairing all CMT meetings (may delegate). • Authorisation of any detailed restoration plan. • Delegate tasks and overseeing resumption activities. • Monitor the gathering of business interruption event information. • Promote the wellbeing and safety of all staff. • Liaise with elected body via the Mayor.
--	---

CMT Coordinator	
Staff Position	Risk & Safety Officer
During absence this role will be assumed by	HR Officer
Position Statement	The CMT Coordinator is required to assist the CMT Director in the management of the business resumption activities. The CMT Coordinator must be familiar with the business continuity plan, critical function sub plans and team responsibilities.
Responsibilities	<p>The CMT Coordinator is required to report to the CMT on the currency of individual and business level continuity plans and activities.</p> <p>Responsibilities include:</p> <ul style="list-style-type: none"> • Pre-event coordination of BCP and Sub plans with relevant owners. • Coordination of training for CMT members. • Coordination of testing for the Business Continuity Plan. • Resourcing of Recovery Coordination Centre. <p>On Activation:</p> <ul style="list-style-type: none"> • Open Coordination Centre on direction of CMT Director. • Assisting CMT Director as required. • Liaise with Insurer and manage the insurance requirements. <p>Media Functions:</p> <ul style="list-style-type: none"> • Support the Mayor/General Manager to ensure the dedicated media briefing centre is fit for purpose.

CMT Support	
Staff Position	Organisational Development Services Admin Assistant
During absence this role will be assumed by	Executive Assistant
Position Statement	The CMT Support is responsible for the smooth functioning of the Recovery Coordination Centre (if established) and administrative needs of the CMT.
Responsibilities	<p>Responsibilities include:</p> <ul style="list-style-type: none"> • Maintain working knowledge of BCP & relevant critical function sub plans. • Maintain high level of administration skills. <p>On Activation:</p> <ul style="list-style-type: none"> • If required, assist with the set-up of the Recovery Coordination Centre and arranging stationery, equipment etc.

	<ul style="list-style-type: none"> • Arrange resources to assist CMT members (if required). • Making arrangements for all CMT meetings. • Provide general administrative support (including log of all events and actions, resumption status, CMT members' movements etc). • Create and maintain chronological log of meetings/decisions made.
--	--

CMT Critical Function Coordinators	
Staff Position	See critical function sub plans for responsible officer
Position Statement	The CMT Critical Function Coordinator is responsible for overseeing the development, implementation, and maintenance of sub plans for their specific area(s). The role is required to oversee and manage resumption activities for the sub plan(s) and report regularly to the CMT Director and CMT Coordinator.
Responsibilities	<p>The CMT Critical Function Coordinators are required to report to the CMT on the currency of sub plans and activities.</p> <p>Responsibilities include:</p> <ul style="list-style-type: none"> • Pre-event coordination of Sub plans with the CMT Coordinator. • Provide timely updates and reports on the status of critical function sub plans to the CMT Director and relevant stakeholders. • Participate in monitor and review activities. • Participate in and ensure appropriate levels of training is undertaken. <p>On Activation:</p> <ul style="list-style-type: none"> • Assist in the activation of the BCP and ensure a swift transition to resumption activities. • Provide authorisation for any detailed restoration plans related to critical functions. • Delegate tasks and oversee resumption activities, ensuring they align with the established sub plans. • Promote the wellbeing and safety of all staff.

4. Staff Responsibilities

This section outlines the expectations assigned to individuals or roles within the organisation, ensuring a coordinated response to disruptions and the preservation of critical business functions.

Department Managers are responsible for:

Non-Activation Period

- Having access to electronic current copies of all business continuity documents, sub plans, and contacts of key personnel.
- Reviewing, updating, and testing sub plan(s) for their areas of responsibility. The required frequency is in Section 7, Monitoring and Review, of this document.
- Assessing and escalating incidents to the CMT as necessary.

Activation Period

- Implementing sub plans in their area(s) of control when directed by the CMT.
- Participating in business continuity management and recovery operations as required.
- Participating in post-event reviews as required.

Coordinators, Supervisors, and Gangers are responsible for:

Non-Activation Period

- Cooperating with implementation of this procedure in their section and area(s) of control.
- Participating in training and testing as required.
- Assessing and escalating incidents to the CMT as necessary.
- Reporting any incident to their Manager, Director, or General Manager for assessment.

Activation Period

- Participating in sub plan implementation in their department or acting as the 'alternate' if you have been assigned this role during your manager's absence.
- Participating in continuity management or recovery operations as required.
- Participating in post-event reviews as required.

Staff are responsible for:

Non-Activation Period

- Cooperating with their Manager and Coordinator/Supervisor/Ganger to ensure implementation and compliance with this procedure.
- Participating in training and testing as required.
- Reporting any incident to their Manager, Director, or General Manager for assessment.

Activation Period

- Participating in sub plan implementation in their department as required.
- Participating in continuity management or recovery operations as required.
- Participating in post-event reviews as required.

Risk and WHS are responsible for:

Non-Activation Period

- Adhering to the monitoring and review tasks in Section 7 of this document.
- Reviewing the overall plan and documents every three years in line with a Business Impact Analysis (BIA).
- Ensuring sub plans are tested by Managers and staff are trained regularly as outlined in the monitoring and review Section 7 of this document.
- Developing and delivering or coordinating external providers to conduct relevant training.
- Ensuring a review is conducted at the completion of a business continuity event and procedures and documents are updated as required.

Activation Period

- Supporting as directed by the CMT.
- Participating in continuity management and recovery operations as required.
- Participating in post-event reviews as required.

5. Declaration of a Business Continuity Event

5.1 Notification

On first becoming aware of a possible business continuity event, the relevant function manager is required to assess the situation and if the event is likely to exceed the agreed Maximum Acceptable Outage (MAO) timeframe, then the CMT Director should be notified immediately (where possible, with a follow-up email or personal briefing) detailing the key issues including:

- Nature of the incident – time informed etc;
- Describe business elements impacted (Critical Functions);
- Employees / facility / equipment impacted;
- Any response actions implemented (Critical Function Sub Plan);
- Any media involvement/interest; and
- Any immediate support requirements.

Sub plan elements can be implemented at local level, where appropriate, to address immediate response requirements, even if the event is expected to be resolved within an acceptable period.

5.2 Assessment

On receipt of a notification of an incident that will impact business continuity the CMT Director will:

- Formally note details;
- Notify other members of the CMT (through appropriate communication channels);
- Confirm the details of the incident and appropriate communication strategies;
- Conduct preliminary impact assessment (facility and technology infrastructure);
- Determine if a control centre needs to be opened and alternate work locations are required; and
- Ensure that the Insurer has been formally notified (if appropriate).

5.3 Declaration

The CMT Director is to review the preliminary information and if considered necessary, declare a Business Interruption Event (BIE). The CMT Director is to facilitate the draft communications, both internal and external, for discussion at the initial CMT meeting.

5.4 Recovery Coordination Centre

On the declaration of a Business Interruption Event by the CMT Director and, if deemed appropriate, a recovery coordination centre will be opened. The resourcing and opening of this centre are the responsibility of the CMT Coordinator, with ongoing maintenance and function to be the responsibility of the CMT Support role. Given the variable nature of Business Continuity Events, the following sites have been identified and prioritised.

If the incident does not impact on a Council Office:

- **Bingara** – Roxy Conference Room, 74 Maitland Street, Bingara
- **Warialda** – Warialda Office, 54 Hope Street, Warialda

If the Council Office is uninhabitable, then:

- **Bingara** – The Living Classroom, 1 Killarney Gap Road, Bingara
- **Warialda** – Warialda Training Room, JA McGregor Drive, Warialda
- **Remotely** – Via Teams conferencing (working remotely)

A full list of Recovery Coordination Centres has been identified and listed with details in Section BCI 7 of this document.

5.5 Initial CMT Meeting

The CMT Director is to call the initial CMT meeting to obtain more detailed information from the relevant business areas impacted, including:

- Staff;
- Any associated Emergency Services issues;
- Building facilities;
- Public relations/media;
- Damage/security;
- Salvage of building and/or IT equipment; and
- Review and confirmation of delegation of authorities for staff.
- Ensuring sub plans are being implemented as required.

Ensure all team members understand their responsibilities and their assigned tasks.

During the meeting, information will have been gathered by the various CMT members to produce an evaluation of the incident. A formal record of the meeting is to be collated by the CMT Support person, with particular emphasis on items to be actioned. This record needs to be regularly reviewed and updated as additional information comes to hand.

The CMT Director is to manage the restoration of business activities in line with the responsibilities defined in the BCP.

5.6 Authority

It is Council's policy that the Mayor (or General Manager as delegate) is Council's key spokesperson and may divulge information to the media. No other employee, contractor, or service provider is authorised to release information to the media unless under delegation from the General Manager.

The General Manager will determine where practicable, in consultation with other senior management and the Mayor, the appropriate communication strategy in the circumstances.

5.7 General Statement to the Media

A well-coordinated approach to managing communications is critical during major incidents to minimise risks to the community and Council through issuing of incorrect information. In the event of a major incident, particularly after-hours, there may be a period of time elapsed before the designated media spokesperson is in a position to respond to media enquiries. Should any staff member be approached by media representatives they should provide no comment but take details and advise the CMT Director or appropriate spokesperson of the contact (refer Media Enquiry Form BCI 5). They should provide the CMT Director with the journalist's details as soon as possible, along with any background and relevant information about the event.

Depending on the nature of the incident, other agencies may take a lead or coordinating role in communications.

5.8 Business Continuity Instructions (BCI)

Upon declaration of an interruption event, the following instructions have been developed to provide assistance on the steps to take during the initial response. However, any restoration plan developed by the CMT will take precedence over the respective instruction.

Instruction Title

BCI 1	Emergency Contacts – Internal
BCI 2	Emergency Contacts – External
BCI 3	CMT Initial Meeting Agenda
BCI 4	Media Release (Initial Holding Statement)
BCI 5	Media Enquiry Form
BCI 6	Staff Notification Email / Message
BCI 7	Business Continuity and Recovery Coordination Centre Options
BCI 8	Alternate Work Locations

BCI 1 Emergency Contacts – Internal

Continuity Management Team

CMT Position	Staff Position	Contact Details	Alternate Staff Position	Contact Details
CMT Director	General Manager	Max Eastcott 0427 240 112	Deputy General Manager	Leeah Daley 0428 291 212
CMT Coordinator	WHS & Risk Officer	Kaylea Perry 0474 905 067	Deputy General Manager	Leeah Daley 0428 291 212
CMT Support	Organisational Development Services Admin Assistant	Sarah Scrivener 0460 001 358	Executive Assistant	Bronwyn Wilson 0459 985 433
CMT Critical Function Coordinator – Customer Service	Finance Manager	Graham Cutmore 0448 297 984	Chief Financial Officer	Helen Thomas 0419 302 152
CMT Critical Function Coordinator – Information Technology	Business Improvement & IT Manager	Justin Hellmuth 0427 163 846	Information Technology Officer	Ben Perry 0459 928 618 Jeff Geraghty 0400 199 310
CMT Critical Function Coordinator – Records	Business Improvement & IT Manager	Justin Hellmuth 0427 163 846	Records Officer	Mel Frewen 0488 577 750
CMT Critical Function Coordinator – Payroll	IP&R and Governance Officer	Casey McClymont 0460 013 113	Business Improvement & IT Manager	Justin Hellmuth 0427 163 846
CMT Critical Function Coordinator – Social Services	Social Services Manager	Suzanne Webber 0427 241 931	Bingara Preschool Director	Charmaine Reading 0429 260 532

Others

Position	Contact Name	Contact Number
Procurement Officer	Michael Bone	0499 877 548
Media & Comms	Carmen Southwell	0428 241 542

BCI 2 Emergency Contacts – External

Service	Company	Contact Details
Desk Phones	GoTo	Ph: 1800 091 811
Mobile Phones	Telstra	Ph: 132 253
Internet Services	Aussie Broadband	Ph: 1300 880 905
Electrician	Warialda Electrical Michael Hayes Electrical	Ivan Cooper M: 0429 061 691 Michael Hayes M: 0427 293 159
Plumber	Internal Staff Member Christie's Plumbing & Septic Cleaning Inverell	Brendan Cutlack M: 0427 241 599 M: 0429 393 900
Banking Services	National Australia Bank	Brianna Fea M: 0407 254 449 Emma Walmsley Ph: (02) 7226 0561
Security	Strategy Security	Strat Bartlett Ph: (02) 6721 0995
Locksmith	Northwest Locksmiths TMW	Ph: (02) 6766 6188
Waste Removal	JR Richards & Sons	Ph: (02) 6555 7007
Insurance	Workers Comp – State Cover General Insurance – Statewide (JLT)	Anthony Abousawan M: 0477 200 932 Matthew De Witt M: 0417 898 185
Electricity	Small Sites – AGL Large Sites – Shell Energy	Shona Guilfoyle – 0437 344 803 Ph: (08) 6318 6412
Emergency Services – 000 (Police, Fire, Ambulance)	Australian Government – Department of Home Affairs	Ph: 000
NSW SES	NSW SES	Ph: 132 500
Police (non-emergency)	Australian Government – Department of Home Affairs	Ph: 131 444
High Schools	Warialda High School Bingara Central School	Shelley Way Ph: (02) 6729 1000 Brooke Wall Ph: (02) 6724 1606
Service NSW	Service NSW	David Finlayson M: 0466 331 609 Ph: (02) 8059 2060
Centrelink	Services Australia	Kasey Brand Ph: (02) 4985 6448 M: 0499 864 203

BCI 3 CMT Initial Meeting Agenda

The CMT Director is to call the initial CMT meeting to obtain more detailed information from the relevant business areas impacted, including:

- Staff;
- Any associated Emergency Services issues;
- Building facilities;
- Public relations/media;
- Damage/security;
- Salvage of building and/or IT equipment;
- Review and confirmation of delegation of authorities for staff; and
- Ensuring sub plans are being implemented as required.

During the meeting, information will have been gathered by the various CMT members to produce an evaluation of the incident. A formal record of the meeting is to be collated by the CMT Support person, with particular emphasis on items to be actioned. This record needs to be regularly reviewed and updated as additional information comes to hand.

Other Issues for Consideration

- Scheduling of site visit
- Identification of affected departments
- Public notification
- Schedule of staff meetings
- Development of initial plan for operations (short term)
- Allocation of temporary work locations.

BCI 4 Media Release (Initial Holding Statement)

BCI 4.1 – Business Enquiry Record Form

On (*insert day and date*) at approximately (*insert time*) Council experienced a business interruption event (*describe event*), as a result of this event the following services are currently impaired:

- Rates
- Water & Sewer
- Roads
- Community Services

Services currently not impacted by the business interruption include:

- Libraries
- Meals on Wheels

Workarounds are currently being put in place in line with Council's Business Continuity processes.

Council will advise the community through our media channels once service delivery strategies have been confirmed.

Council's contact number remains **02 6724 2000** and will be manned from **8.30am to 5.00pm**.

Issued by

Max Eastcott
 General Manager
 Gwydir Shire Council
 (*insert time*)
 (*insert date*)

BCI 5 Media Enquiry Form

BCI 5.1 – Media Enquiry Record Form

Business Continuity – Media Enquiry Record Form			
Taken by:			
Issue:			
Date:		Time of call:	
Journalist name:			
Contact numbers:			
Media outlet:			
Deadline:			
Publication date:			
Question			
Taken by:			
Issue:			
Response by:			
Position in GS Council:			
Response:			
Date:		Time:	

BCI 6 Staff Notification Email / Message

Situation

At (insert time) on (insert date) Council experienced (insert event) which has impacted on (insert impacts). The following services have been impacted (insert losses/impacts).

As a consequence, the General Manager has declared a Business Interruption Event and the Continuity Management Team is working to restore Council's critical business functions.

Plan

Council has now temporarily varied operations to ensure we can continue to provide key services to our customers. The continuity management team is reassessing the allocation of personnel which may involve reassignment of staff to new roles within the organisation for a short period of time.

Administration

The continuity management team is as follows:

- CMT Director – *Insert Person*
- CMT Coordinator – *Insert Person*
- CMT Support – *Insert Person*
- CMT Critical Function Coordinator - *Insert Person(s)*

A staff briefing will be conducted at (insert time) at (insert location) to discuss the Council's strategy and the role you will play in restoration. Meanwhile, all staff must ensure they have access to the following resources (list resources) and protective clothing (insert clothing requirements).

All continuity actions must be authorised by the CMT Director.

All staff must keep a personal log of actions and requests.

Communications

Any urgent questions or concerns should be directed to [INSERT NAME AND PHONE NUMBER] and we will keep you updated.

The primary mode of communication within the organisation will be (insert communication method). As a result, priority will be given to the following functions (insert functions).

Council's business telephone number has been temporarily diverted to (insert location).

CMT Director

(insert time)

(insert date)

BCI 7 Business Continuity and Recovery Coordination Centre Options

The following centres can be established as the Business Continuity and Recovery Coordination Centre depending on the location of the significant event and as determined by the General Manager:

Location	Capacity for Extra Staff	Meeting Room	Toilet Facilities	Kitchen Facilities	IT Connectivity	Comments
Roxy Conference Room	Limited	Yes	Yes	Yes	Yes, Council Network, Wi-Fi	The internet service is only fibre to the node (FTTN) and would struggle with a high volume of users.
Warialda Office	Limited	Yes	Yes	Yes	Yes, Council Network, Wi-Fi	The internet service is Enterprise Ethernet and can sufficiently handle extra capacity.
The Living Classroom	Limited	No	Yes	Yes	Yes, Council Network, Wi-Fi	Internet service is fibre to the premise (FTTP), and the internet speeds can be increased in an event.
Warialda Depot Training Room	Significant	No	Yes	Yes	Yes, Council Network, Wi-Fi	The internet service is only fibre to the node (FTTN) and would struggle with a high volume of users.

The General Manager will advise the Business Continuity Team of the location of the Business Continuity and Recovery Coordination Centre which will be the location of meetings of the Business Continuity Team and will be equipped with adequate facilities and resources to allow the Business Continuity Team to implement the Business Continuity and Recovery Plan.

The existing telephone numbers of the Council (02) 6724 2000 and (02) 6729 3000 as well as Councils email mail@gwydir.nsw.gov.au are to be redirected as soon as possible to the Business Continuity and Recovery Coordination Centre.

The Customer Contact Officers and Executive Services Team will be assigned to the Business Continuity and Recovery Coordination Centre, as soon as possible, to assist the Business Continuity Team with all telephone support, communication, correspondence and to facilitate business as usual. Additional Staffing resources will be obtained at the direction of the General Manager or Chairperson of the Business Continuity Team, should the Business Continuity and Recovery Plan be activated simultaneously with the Gwydir Shire Council Local Disaster Management Plan and Gwydir Shire Council Disaster Recovery Plan.

BCI 8 Alternate Work Locations

In the event that a primary work location becomes unavailable, the alternate work location(s) suitable is outlined in the table below. These are to be used, unless otherwise advised. If possible, working from home arrangements will be made.

Primary Work Location	Alternate Work Location
Warialda Office Total Staff: 20~	Customer Service: Warialda VIC Staff: Warialda Depot
Warialda Visitor Information Centre: Total Staff: 2	Staff: Warialda Office
Warialda Depot Workshop Office Spaces: 2 Floor Staff: 4~	Bingara Workshop
Warialda Depot Office Total Staff: 4-5	Stores: Bingara Depot Other Staff: Warialda Chambers
Warialda Library Total Staff: 1	Warialda Office/Warialda VIC
Warialda CHSP Total Staff: 1	Naroo Aged Care Facility
Warialda Toy Library: Total Staff: 1	Warialda Office/Warialda VIC
Warialda Automotive Training Centre Total Staff: 1	Office functions can be performed in the GLR office.
GLR Office Total Staff: 3	Warialda Office
Naroo Aged Care Facility	Follow Naroo's Disaster Management Processes
Roxy Theatre Total Staff: 15	Customer Service: Bingara Library Staff: The Living Classroom
Bingara IT Office Total Staff: 7	Warialda Archive Room, or as alternative, The Living Classroom/Roxy Conference Room.
Bingara CHSP: Total Staff: 2	Bingara Library/Bingara Toy Library
Bingara Courthouse Total Staff: 8	The Living Classroom VIC: Bingara Library
Bingara Depot Workshop Total Staff: 2~	Warialda Workshop
Bingara Depot Office: 7	The Living Classroom/Roxy Conference Room
Bingara Water Treatment Plant:	Sewerage Treatment Plant

Office Spaces: 2 Total Staff: 2	
Bingara Sewerage Treatment Plant Total Staff: 1	Water Treatment Plant
Bingara Library Total Staff: 1	Bingara Toy Library/Roxy Conference Room
Bingara Toy Library Total Staff: 1	Bingara Library
Bingara Preschool Total Staff:	Follow Bingara Preschool Emergency Management Plan.
Tharawonga Offices	Follow Tharawonga Emergency Management Plan.
North Star Depot Total Staff:	Warialda Depot
Centrelink: Total Staff: 1	<i>Equipment is owned and managed by Services Australia. Service would close and customers referred to Inverell.</i>
Service NSW: Total Staff (Bingara): 1	<i>Information Services Disaster Recovery processes would see Service NSW have access to internet services and a place to operate. The equipment and infrastructure are managed by Service NSW.</i>

6. Critical Function Sub Plans

6.1 Critical Function 1: Customer Service

Responsible Officer: Finance Manager

Reviewed: Graham Cutmore

Identified Critical Business Functions	
<p>Act as liaison between council business functions, operations and community. Provide information to the community – email, phone and face to face. Receipt transacted monies.</p>	
Overview of Functions	
<p>The Customer Service function is vital for ensuring uninterrupted support during disruptions. It focuses on clear communication, service continuity, resource planning, and staff training. Structure around response, recording and reporting, assisting in the planning of and allocation of resources.</p>	
Business Impact Analysis	
Business Impact of Function Loss	<ul style="list-style-type: none"> Loss of information and relationship between council staff and community Monies not transacted/receipted No service delivery
Penalties for Non-Delivery	<ul style="list-style-type: none"> Damaged reputation Workload accumulation Loss of information delivery to general community
Functional Interdependencies	<ul style="list-style-type: none"> Financial functions – Accounts payable/receivable, rates Payroll Customer service (CRMs)
Current Resources Premises/ Equipment/Staff	<ul style="list-style-type: none"> 11 Laptops 9 Phone lines 0 Mobile phones 1 Internet connection A3 Multifunction Device
Minimum Resources Required	<ul style="list-style-type: none"> IT support services Power for at least two workstations running with network access Internet access and connectivity to Council network Access to Council's main phone line
Alternate Manual Process or Workaround	<ul style="list-style-type: none"> Use Carbon copy receipt book. Issue handwritten receipts to customer including customer details and details of payment. Receipt through authority when systems are back online and post/email receipt to customer. Advise of alternate payment methods, such as online payments, BPay and Australia Post
Disruption Scenario	Max Acceptable Outage (MAO)
<ul style="list-style-type: none"> Loss of building Loss of staff IT outage 	<ul style="list-style-type: none"> 3 days 3 days 1 day

• Security threat	• 1 day
Key Roles	
Authority for invoking plan	Finance Manager
Key decision makers to be assembled	General Manager, CFO, Finance Manager, Business Improvement & IT Manager, Risk & WHS Officer
Internal stakeholders	Councillors, Staff
External stakeholders	Community Groups, Residents, Rate Payers, Media, Creditors, Grant funding bodies, OLG.
Pre-Event Preparedness	
<ul style="list-style-type: none"> • Ensure receipt books are always available at front counters. • Ensure customer service staff are aware of the protocols. • Ensure customer service staff are aware of alternate payment methods to advise customers. 	
Emergency Response	
<ul style="list-style-type: none"> • Building cleared of community and non-integral staff . • Notice provided to the internal and general community, posting notices on all entry/exit doors and community notice boards. • Website update. 	
Continuity Management	
<p>In the event of a business interruption event that exceeds the MAO the following responses may be appropriate:</p> <ul style="list-style-type: none"> • Identify a suitable site to function if required, organise resources. • Utilise other council trained staff. • Organise receipt books, manual credit card facilities and spreadsheet, notebooks for recording purposes. • Till to be balanced and banked. • Information updated for community awareness, as and when received. 	
Communication Considerations	
<p>Internal:</p> <ul style="list-style-type: none"> • All employees • Councillors 	<p>External:</p> <ul style="list-style-type: none"> • Community to be informed via Council as outlined in the BCP.
Further Treatment / Action Plans	
Treatment/action:	Review Customer Service protocols, identify opportunity for improvements where applicable and implement.

6.2 Critical Function 2: Information Technology

Responsible Officer: Business Improvement & IT Manager

Reviewed:

Identified Critical Business Functions	
Provision of customer services to members of the community.	
Overview of Functions	
The Information Technology function includes the telecommunications, network communications, hardware infrastructure and software, ensuring the functioning of essential technological infrastructure.	
Business Impact Analysis	
Business Impact of Function Loss	<ul style="list-style-type: none"> • Whole of business inability to access information and provide critical services. • Reduced means of communication. • Potential data loss.
Penalties for Non-Delivery	<ul style="list-style-type: none"> • Significant effect on functional dependencies and the ability to provide them. • Damaged reputation.
Functional Interdependencies	<ul style="list-style-type: none"> • Financial functions – AR, AP and Revenue. • Payroll. • Customer Service. • Records Management. • Planning & Development. • All other office-based functions.
Current Resources Premises/ Equipment/Staff	<ul style="list-style-type: none"> • Hardware (workstations, servers, network devices) • On-premise backup – daily • Offsite backup (cross-site) – every 48 hours • Offsite backup (cloud) – weekly • Disaster recovery replication (cloud) – daily • Cloud storage – OneDrive, SharePoint • Server room – Air-conditioned, 15-amp power, enterprise fibre internet connection
Minimum Resources Required	<ul style="list-style-type: none"> • IT support services • Power for at least two workstations running with network access • Internet access and connectivity to Council network • Ability to backup daily and store backups offsite • Mobile Phone
Alternate Manual Process or Workaround	As per continuity plans as stated in action plans section.
Disruption Scenario	Max Acceptable Outage (MAO)
<ul style="list-style-type: none"> • Power loss • Cyber incident • Loss of hardware • Loss of building 	1 day

Key Roles	
Authority for invoking plan	Business Improvement & IT Manager
Key decision makers to be assembled	General Manager, Business Improvement & IT Manager, Risk & WHS Officer, Procurement Officer
Internal stakeholders	Councillors, Staff
External stakeholders	Community Groups, Residents, Rate Payers, Media
Pre-Event Preparedness	
<ul style="list-style-type: none"> • Cloud disaster recovery backup, ready for a failover event. • Backups internal and offsite and ability to recover data. • Cloud available applications that would remain unaffected by our internal services. 	
Emergency Response	
<p>On being advised of a business interruption, event these following immediate responses should be considered:</p> <ul style="list-style-type: none"> • If networking equipment malfunction, instate DR recovery plan. • Select location for operations. • Configure devices to ensure other critical functions can operate as soon as possible. • Recover data from backup. • Ensure data recovered from appropriate point in time. 	
Continuity Management	
<p>In the event of a business interruption event that exceeds the MAO the following responses may be appropriate:</p> <ul style="list-style-type: none"> • Communicate situation with internal stakeholders. • Move to alternate suitable site (if applicable). • Obtain internet access if not already available – may need mobile devices at alternate site. • Instate cloud disaster recovery site. • Implement alternate procedure for backup and storage. • Procure replacement network equipment as soon as possible. 	
Communication Considerations	
Internal:	External:
<ul style="list-style-type: none"> • All employees • Councillors 	<ul style="list-style-type: none"> • Community to be informed via Council as outlined in the BCP. • If a data breach has occurred, the procedures as outlined in the Data Breach Policy are to be implemented. • If it is a cyber incident, the procedures as outlined in the Cyber Incident Response Plan are to be implemented.
Further Treatment / Action Plans	
Treatment/action:	Implement IT Disaster Recovery Plan.
	Implement Cyber Incident Response Plan.
	Implement Data Breach Policy

6.3 Critical Function 3: Records

Responsible Officer: Business Improvement & IT Manager

Reviewed:

Identified Critical Business Functions	
Classification, storage, distribution, and retrieval of information. Provide administration services for Electronic Data Records Management System (EDRMS)	
Overview of Functions	
The management of the organisation’s information resources. Including creation, capture, registering, classifying, and indexing, storing, archiving, retrieval and disposal of records and development of strategies to manage records.	
Business Impact Analysis	
Business Impact of Function Loss	<ul style="list-style-type: none"> Loss of records Records inappropriately captured Loss of legislative compliance from record loss
Penalties for Non-Delivery	<ul style="list-style-type: none"> Loss of information Incorrect information Damaged reputation
Functional Interdependencies	<ul style="list-style-type: none"> Content Manager Warialda records room Online Storage (OneDrive, Sharepoint, Emails, etc) Authority system
Current Resources Premises/ Equipment/Staff	<ul style="list-style-type: none"> 2 Laptops 2 Phone lines 1 Mobile phones Internet connection
Minimum Resources Required	<ul style="list-style-type: none"> 1 Laptop Internet access and connectivity to Council network A3 Scanner
Alternate Manual Process or Workaround	Continue to ensure documents are digitalised and when possible, import them into our EDRMS.
Disruption Scenario	Max Acceptable Outage (MAO)
<ul style="list-style-type: none"> Loss of building Loss of staff IT outage 	1 Day
Key Roles	
Authority for invoking plan	Business Improvement & IT Manager
Key decision makers to be assembled	General Manager, Deputy General Manager, Business Improvement & IT Manager, Records Officer, Risk & WHS Officer
Internal stakeholders	Staff
External stakeholders	NSW State Records, Cyber NSW

Pre-Event Preparedness	
<ul style="list-style-type: none"> • Ensure all new records are digitised to an acceptable standard. • Work towards having our on-site physical records are being digitised. • Ensure our records database is regularly backed up. 	
Emergency Response	
<ul style="list-style-type: none"> • Continuation of our record collection and storage digitally. • Continue our normal operation when possible. 	
Continuity Management	
<ul style="list-style-type: none"> • Identify suitable site to run back-up files. • Utilise other trained council staff. • Manual entries, then type into system when operational. • Computer entry, type into spreadsheet. • Date Stamp. • Set up temporary file system. 	
Communication Considerations	
Internal: <ul style="list-style-type: none"> • Provide all employees with up to date information use alternate methods if no email available. 	External: <ul style="list-style-type: none"> • NSW State Records – for our onsite physical records and reporting on our digital store. • Cyber NSW – If a data breach has occurred, the procedures as outlined in the Data Breach Policy are to be implemented. •
Further Treatment / Action Plans	
Treatment/action:	Continue digitisation of records.
	Minimise onsite physical records.

6.4 Critical Function 4: Payroll

Responsible Officer:

Reviewed:

Identified Critical Business Functions	
The preparation and process of Council fortnightly payroll.	
Overview of Functions	
The Payroll function is essential for maintaining financial stability during disruptions. It is designed to ensure timely and accurate payment processing for employees.	
Business Impact Analysis	
Business Impact of Function Loss	<ul style="list-style-type: none"> Aggrieved employees Absenteeism
Penalties for Non-Delivery	<ul style="list-style-type: none"> Poor industrial relations Non-delivery of other critical services Statutory requirements not met, i.e., superannuation and taxation
Functional Interdependencies	<ul style="list-style-type: none"> Authority payroll systems Authority API ElementTime system
Current Resources Premises/ Equipment/Staff	<ul style="list-style-type: none"> 2 Laptops 2 Phone lines 2 Mobile phones Internet connection
Minimum Resources Required	<ul style="list-style-type: none"> 1 Laptop Internet access and connectivity to Council network Mobile Phone
Alternate Manual Process or Workaround	If our online timesheet system goes down for any reason, revert to manual timesheet process.
Disruption Scenario	Max Acceptable Outage (MAO)
<ul style="list-style-type: none"> Loss of building Loss of staff IT outage 	Non-pay week – 5 days Pay week – 1 day
Key Roles	
Authority for invoking plan	Deputy General Manager
Key decision makers to be assembled	General Manager, Deputy General Manager, Business Improvement & IT Manager, Risk & WHS Officer
Internal stakeholders	Staff
External stakeholders	ElementTime
Pre-Event Preparedness	
<ul style="list-style-type: none"> Ensure documentation is digitalised and up to date. 	

Emergency Response	
<ul style="list-style-type: none"> • Consult with key decision makers on appropriate course of action i.e. when will IT access again be available, discuss options (bank) • If deemed necessary, process standard hour pay run as per procedure. • Communicate with all stakeholders 	
Continuity Management	
<p>In the event of a business interruption event that exceeds the MAO the following responses may be appropriate:</p> <ul style="list-style-type: none"> • Identify a suitable site to function if required, organise resources. • Information updated for staff awareness, as and when received. 	
Communication Considerations	
<p>Internal:</p> <ul style="list-style-type: none"> • Provide all employees with up-to-date information use alternate methods if no email available. 	<p>External:</p> <ul style="list-style-type: none"> • Liaise with NAB • Notify applicable statutory bodies: Superannuation, ATO (Child Support)

6.5 Critical Function 5: Social Services

Responsible Officer: Social Services Manager

Reviewed:

Identified Critical Business Functions	
The management of the students within our childcare services under Gwydir Shire Council.	
Overview of Functions	
The Social Services function is essential for maintaining students safety during disruptions. It is designed to ensure prompt and safe care of students.	
Business Impact Analysis	
Business Impact of Function Loss	<ul style="list-style-type: none"> Disruption of service to community
Penalties for Non-delivery	<ul style="list-style-type: none"> Damaged reputation Aggrieved parents and carers
Functional Interdependencies	<ul style="list-style-type: none"> Bingara Preschool Tharawonga Mobile Preschool
Current Resources Premises/ Equipment/Staff	<ul style="list-style-type: none"> Tharawonga – 5 Staff Maximum – 20 Children Maximum Bingara Preschool – 6 Staff Maximum – 28 Children Maximum
Minimum Resources Required	<ul style="list-style-type: none"> 1 Laptop, 1 Mobile phone and 1 Satellite Phone – Tharawonga 1 Laptop and 1 Mobile phone – Bingara Preschool
Disruption Scenario	Max Acceptable Outage (MAO)
<ul style="list-style-type: none"> Listed in Emergency Management Plans 	
Key Roles	
Authority for invoking plan	Social Services Manager
Key decision makers to be assembled	General Manager, Deputy General Manager, Business Improvement & IT Manager, Risk & WHS Officer, Aged Care Services Manager
Internal stakeholders	Staff
External stakeholders	Parents/Family Contacts (within Emergency Management Plan – Bingara Preschool) SafeWork NSW
Pre-Event Preparedness	
<ul style="list-style-type: none"> Review and Test Emergency Management Plan – Bingara Preschool Review and Test Emergency Management Plan – Tharawonga 	
Emergency Response	
<ul style="list-style-type: none"> Implement Emergency Management Plan – Bingara Preschool Implement Emergency Management Plan – Tharawonga 	
Continuity Management	

<p>In the event of a business interruption event that exceeds the MAO the following responses may be appropriate:</p> <ul style="list-style-type: none"> • Identify a suitable site to function if required, organise resources. • Information updated for staff and carer awareness, as and when received. 	
<p>Communication Considerations</p>	
<p>Internal:</p> <ul style="list-style-type: none"> • Staff 	<p>External:</p> <ul style="list-style-type: none"> • Parents • SafeWork NSW
<p>Further Treatment / Action Plans</p>	
<p>Treatment/action:</p>	<p>Emergency Management Plan – Bingara Preschool</p>
	<p>Emergency Management Plan – Tharawonga</p>

7. Monitoring and Review

Monitoring and review is an integral component of the BCP process. Council recognises and is committed to ensure the following monitoring and review strategy is implemented.

	Activity for Review	Accountability	Timeframe
1	Business Continuity Plan (overarching plan)	Risk Manager	Monitor annually and action as required.
2	Business Continuity Plan Training	Risk Manager	Annual training brief or refresher session.
3	Business Continuity Plan Exercise	Risk Manager	Annual desktop exercise Simulation exercise every 2 years
4	Critical Function Sub Plans	Sub Plan Owner	Annual Review

8. Related Documents

Incident Response Plans

IT Disaster Recovery Plan

Cyber Incident Response Plan

Emergency Management Plan – Bingara Preschool

Emergency Management Plan – Tharawonga



Gwydir Shire Council
**Fraud and Corruption
Prevention Policy**

File Reference: ## Version 1:
Council Pages 10
Resolution:

Table of Contents

.....	1
Gwydir Shire Council.....	1
Fraud and Corruption Prevention Policy.....	1
Document data.....	3
Revision record.....	3
Purpose.....	4
Policy Scope.....	4
Policy Statement (insert any definitions here).....	4
Policy Commitment.....	4
DEFINITIONS.....	5
5.1. Fraud.....	5
5.2. corruption.....	5
Examples of Corrupt Conduct.....	5
OUR RESPONSIBILITIES.....	6
All Employees.....	6
Councillors.....	6
General Manager.....	6
Directors, Managers and Supervisors.....	7
Audit, Risk and Improvement Committee.....	7
Rights of the Employee.....	7
FRAUD PREVENTION AND CONTROLS.....	7
Prevention.....	7
1.1. Mitigation Practices.....	8
REPORTING AND INVESTIGATION.....	9
Internal Reporting of fraud and corruption.....	9
Protection of Whistleblowers.....	9
Discipline and Investigation.....	9
RELATED LEGISLATION, POLICIES AND REVIEW.....	9
Related Legislation and Policies.....	9
Review.....	10

Document data

Department	Corporate Services
Responsible Manager	CFO
Date Adopted	or Approved under Delegation, General Manager
File reference	
Version no	1
Next Review	April 2028

Revision record

Date	Version	Revision details	Officer	Next Review
April 2024	1	initial document	H Thomas	April 2028

Purpose

To state Gwydir Shire Council's commitment to the prevention of fraud and corruption and to outline the methodology to deter and detect fraudulent behaviour and corrupt conduct.

This policy outlines the responsibilities of our people in regard to the prevention, detection and investigation of fraudulent and corrupt activities in Gwydir Shire Council.

Policy Scope

This policy applies to any suspected or confirmed irregularity involving all Gwydir a Council employees, Councillors and external parties including contractors, community representatives, volunteers and consultants.

Policy Statement (insert any definitions here)

Gwydir Shire Council will not tolerate corrupt conduct by employees, Councillors, contractors, volunteers or external parties.

This policy will contribute to:

- a) Protecting the physical assets, funds and resources of Gwydir Shire Council from providing personal benefit to employees, contractors, volunteers and third parties whilst creating an environment of public trust and security;
- b) protecting Council employees, Councillors, volunteers, contractors and consultants from false accusation or public perception of corrupt or fraudulent behaviour; and
- c) protecting Council's reputation.

Policy Commitment

Through the Executive Management Team and the Audit, Risk and Improvement Committee (ARIC), Gwydir Shire Council will support a culture that is committed to:

- a) minimising the opportunities for corrupt conduct by employees, members of the public, Councillors, contractors, volunteers and customers;
- b) creating awareness of this policy and encourage the reporting of possible risks;
- c) detecting, investigating and disciplining/prosecuting fraud and corruption;
- d) reporting corrupt conduct to appropriate authorities;
- e) developing and implementing a fraud and corruption risk assessment strategy to assist in the identification and management of corruption risks across Council;
- f) strengthening systems where fraud is detected, and implementing controls to mitigate the chance of repetition or further fraudulent activity; and

- g) encouraging confidence in Council's ability to manage fraudulent and corrupt behaviour.

DEFINITIONS

5.1. Fraud

The definition of **Fraud** by the NSW Audit Office is:

"a deliberate and premeditated turn of events which involves the use of deception to gain advantage from a position of trust and authority. The type of events include: acts of omission, theft, the making of false statements, evasion, manipulation of information and numerous other acts of deception".

Fraud and corruption can be committed by one person or in collusion with others. Such persons may be employees of Council, Councillors, volunteers, external companies, external individuals, contractors or consultants.

5.2. Corruption

The *Independent Commission Against Corruption Act 1988* (NSW) provides a definition of corruption which includes but is not limited to:

- a) *any conduct of any person (whether or not a public official) that adversely affects, or could adversely affect, either directly or indirectly, the honest or impartial exercise of official functions by any public official, any group or body of public officials or any public authority;*
- b) *any conduct of a public official that constitutes or involves the dishonest or partial exercise of any of his or her official functions;*
- c) *any conduct of a public official or former public official that constitutes or involves a breach of public trust; or*
- d) *any conduct of a public official or former public official that involves the misuse of information or material that he or she has acquired in the course of his or her official functions, whether or not for his or her benefit or for the benefit of any other person.*

Examples of Corrupt Conduct

Corrupt conduct examples include:

- a) misappropriation of Council funds;
- b) exerting influence in order to receive a benefit for oneself or others;
- c) using Council information to bribe or threaten individuals or businesses;
- d) taking of equipment or supplies (including stationery or portable electrical equipment) from Council;
- e) conspiring unfairly with others to determine a tender or development application;
- f) receiving benefits to process development applications that do not meet statutory, regulatory or Council requirements;
- g) enhancing one's financial position through the use of Council information;

- h) unauthorised private use of a Council motor vehicle or other assets of Council;
- i) using Council money for a private benefit;
- j) accepting gifts that contravene the Code of Conduct (with failure to disclose the gift);
- k) falsifying timesheets;
- l) running a private business during working hours or with Council resource;
- m) falsifying travel claims and/or reimbursements;
- n) falsifying documents to obtain benefits that would otherwise not be provided;
or
- o) election bribery, election funding offences and election fraud.

OUR RESPONSIBILITIES

All Employees

All Council employees are responsible for:

- 1) Performing their functions and duties with diligence, honesty, integrity and impartiality.
- 2) Complying with this policy and all legislative requirements to ensure they are not participating in corrupt or fraudulent behaviour.
- 3) Reporting any suspicion of fraudulent or corrupt behaviour to the General Manager, the appropriate Manager or the Mayor if such behaviour concerns the General Manager, or by utilisation of Council's Public Interest Disclosures Policy.
- 4) Reporting any identified weaknesses in internal controls that could potentially facilitate a fraudulent or corrupt act.

Councillors

Councillors are responsible for performing their functions and duties with diligence, honesty, integrity and impartiality; and reporting all cases of suspected fraudulent or corrupt behaviour to the General Manager, Mayor, Disclosures Officer or relevant external agencies.

General Manager

The General Manager is ultimately responsible for the prevention, detection and reporting of fraud and corruption through the implementation of appropriate and effective internal control systems.

The General Manager is responsible for ensuring that Council's Code of Conduct and associated policies are extended to all Council employees and Councillors and promoting Gwydir Shire Council's commitment to preventing fraud and corruption to the local Community.

The General Manager has a duty under s11 of the ICAC Act 1998 to report to ICAC any matter that is suspected to concern or may concern corrupt conduct and report criminal offences to the NSW Police.

Directors, Managers and Supervisors

Directors, Managers and Supervisors are also responsible for the prevention, detection and reporting of fraud and corrupt conduct by ensuring:

- 1) There are mechanisms in place within their area of control to assess the risk of fraud and corrupt conduct and to manage such risks by appropriate internal controls.
- 2) The promotion of employee awareness, training and education on the prevention of fraud and corruption.
- 3) Compliance with all relevant policies and practices.
- 4) Reporting of any fraud or corruption matters to the General Manager.
- 5) That reasonable steps are undertaken to ensure that Council contractors within their area of control adhere to the provisions of this policy.

Audit, Risk and Improvement Committee

Council's Audit, Risk and Improvement Committee (ARIC) plays a pivotal role in the governance framework. It provides Council with independent oversight in the areas of risk, control, compliance and financial reporting. ARIC consists of two Councillors, three independent members of the public and Council staff. Note that the Council staff do not have voting rights.

Rights of the Employee

Council recognises, that where an allegation of fraud may also involve criminal conduct, then, by law, the employee's right to silence will be recognised. Council will also recognise the employee's right to due process, independent union representative, support personnel and legal advice.

Council will take seriously all reports of suspected fraud and conduct appropriate investigations. Council reserves the right to determine who will be informed of the allegations and when, subject to any legal obligations. Council may investigate an allegation without informing the individual(s) to whom the allegation relates and may also keep allegations confidential while other agencies are reviewing or investigating the matter. Where disciplinary action is being considered, the suspected officer will be given an opportunity to explain the events at an appropriate time.

FRAUD PREVENTION AND CONTROLS

Prevention

In implementing this policy, Council has identified the fraud and corruption risks across the organisation. The identified areas of high risk of fraud and corruption within Council will assist in the development of management strategies in response to such risks.

Identified Fraud and Corruption Risks for Gwydir Shire Council include (but are not limited to):

- a) Conflicts of Interest;
- b) Bribes, including Gifts and Benefits;
- c) Recruitment and selection;
- d) Procurement, purchasing and tendering;
- e) Development Applications;
- f) Cash handling;
- g) Theft of money, materials and machines;
- h) Delegations;
- i) Time recording;
- j) Use of Council resources;
- k) Stock control;
- l) Obtaining personal benefit by provision of additional service; and
- m) Information technology.

1.1. MITIGATION PRACTICES

Actions that will be taken to minimise the risk of fraud include:

- a) **Governance** – a strong governance framework will ensure appropriate policies exist and knowledge of correct procedures in circumstances of conflicts of interest, gifts and benefits and delegations;
- b) **Leadership** – the behaviour of leaders is seen as important in creating an ethical workplace;
- c) **Risk Management** – identifying where the risks exist and to minimise them;
- d) **Conduct Guidance** – by providing an effective guide to proper behaviour through the Code of Conduct;
- e) **Staff Culture** – an effective internal reporting system and supportive and transparent culture to assist detecting fraud and identifying suspicious behavior;
- f) **Segregation of Duties** – ensuring that multiple officers are involved in processing transactions to reduce the opportunity for fraud as well as error;
- g) **Peer Review** and selective checking by Management – a review of work leads to the sharing of knowledge and discourages fraud;
- h) **Computerised Reporting and Data Analysis** – by identifying high volume, low amount transactions or unusual items can deter staff from fraudulent practices;
- i) **Physical Access** – security needs to reflect the risk of theft such as cash, cheques and other high risk items; and
- j) **Information Security** – information is also susceptible to fraud and needs to be secured.

REPORTING AND INVESTIGATION

Internal Reporting of fraud and corruption

Council will provide support to persons who report instances of fraud, corruption and wrongdoing in accordance with the Gwydir Shire Council Public Interest Disclosures Policy. A separate Council policy details the provisions and procedures covered by the Public Interest Disclosures Act 1994.

The Code of Conduct also establishes responsibility for staff to report breaches.

Protection of Whistleblowers

Council respects that whistleblowers play an important role to ensure that our operations are conducted in accordance with applicable legislative and policy requirements. Council will ensure the safety and confidentiality of whistleblowers and will implement all protections as defined in the Treasury Laws Amendment (Enhancing Whistleblower Protections) Act 2019. Discipline and Investigation.

Discipline and Investigation

Council respects that whistleblowers play an important role to ensure that our operations are conducted in accordance with applicable legislative and policy requirements. Council will ensure the safety and confidentiality of whistleblowers and will implement all protections as defined in the Treasury Laws Amendment (Enhancing Whistleblower Protections) Act 2019. Discipline and Investigation.

Gwydir Shire Council has zero tolerance for corrupt or fraudulent behaviour. Council staff found guilty of such matters will face disciplinary matters pursuant to the Code of Conduct and the Local Government (State) Award. Other (non-staff) Council officers will be disciplined pursuant to Council's Code of Conduct.

All "possible" corruption matters, involving Council officers, have a mandatory statutory reporting requirement to ICAC. ICAC or Council itself can also seek criminal prosecutions by reporting fraud and other corruption matters to the NSW Police Service.

The General Manager must make an initial determination as to whether the matter in question concerns or may concern corrupt conduct. This may entail their own analysis of the circumstances surrounding the matter or utilising another staff member or an investigator to carry out preliminary enquiries on which to base the determination.

After formal notification by the General Manager, ICAC will normally determine if they will investigate the alleged corruption matter. Alternatively, ICAC may instruct Council to carry out their own investigation and report the findings to ICAC. In such circumstances Council should engage an experienced and suitably qualified investigator for the process.

RELATED LEGISLATION, POLICIES AND REVIEW

Related Legislation and Policies

The following are relative to this policy:

- 1) Local Government Act 1993 NSW

- 2) Independent Commission Against Corruption Act 1988
- 3) Public Interest Disclosure Act 1994 NSW
- 4) Treasury Laws Amendment (Enhancing Whistleblower Protections) Act 2019
- 5) Gwydir Shire Council Code of Conduct
- 6) Gwydir Shire Councils Public Interest Disclosures Policy

Review

Council reserves the right to vary, replace or terminate this policy at any time. This policy will be reviewed every 4 years or following an ordinary election of Council, or earlier if there are relevant statutory or State Government policy changes.

Local Government Act 1993

Fraud and Corruption Prevention Control Plan

FOREWORD

Message from the Mayor and General Manager.

Fraudulent and corrupt activity is a pervasive and ongoing risk to Local Government organisations. Gwydir Shire Council's Fraud and Corruption Control Plan endeavours to illustrate how our organisation intends to detect, prevent, and respond to concerns about fraud and corruption.

Fraud and corruption undermine the reputation of staff, councillors, and delegates and has a potentially significant resource cost. Our communities expect us to conduct our business in an ethical and efficient manner; fraudulent activities betray this trust.

Fraudulent and corrupt behaviour is varied; it can be simple and obvious, or complex and difficult to detect. It is essential that our staff and other stakeholders are aware of the risks, and are informed about how they should respond to, mitigate, and manage fraudulent and corrupt activities.

The significance of fraud and corruption cannot be understated; because of this, Gwydir Shire Council has adopted a 'zero tolerance' approach to such behaviours. This Plan incorporates the Fraud Control Framework of the Audit Office of NSW, which provides a comprehensive step by step guide and practical advice for organisations implementing fraud control measures.

This plan applies to and requires the cooperation of Councillors, staff members, contractors, and stakeholders, including customers and members of the community. It is to be read in conjunction with other relevant policies such as Council's Code of Conduct and the Public Interest Disclosures Policy.

Prevention of fraudulent and corrupt activities is an ongoing process; Gwydir Shire Council is committed to ensuring our staff and stakeholders have the information needed to take action. The attitude, commitment, and alertness of our staff and stakeholders is essential for delivering Council's programs and business activities with a high degree of integrity.

John Coulton
Mayor

Maxwell Eastcott
General Manager

PURPOSE

Gwydir Shire Council (We, GSC, or Council) is committed to the prevention of fraudulent and corrupt behaviour, through ethical practices and by adopting a zero-tolerance approach. We aim to minimise the incidence of fraud by implementing and frequently reviewing a range of strategies that aim to prevent, detect, and respond to such behaviour. GSC aims to create an honest work environment that strives to be free from fraud and corruption, while continuing to uphold a high standard of ethical and legal behaviour.

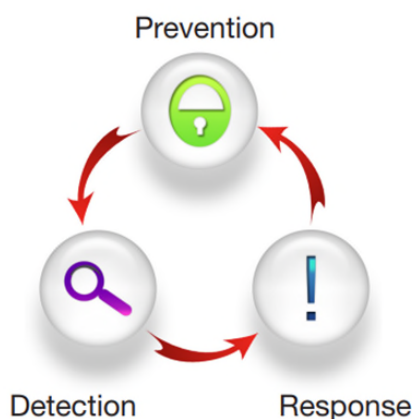

Audit Office of New South Wales | Fraud Control Improvement Kit | February 2015

This Fraud and Corruption Prevention Control Plan (the Plan) has been developed to outline the ethical behaviour standards expected by Council and is complemented by Council’s Fraud and Corruption Prevention Policy 2024. This Plan also incorporates the Fraud Control Framework of the Audit Office of NSW, which is utilised to ensure that appropriate procedures are in place to detect, deter, prevent, and respond to fraud and corruption.

SCOPE

This plan applies to everyone who has any interaction with Council or Council staff to the maximum extent that Council has the authority to require it. This includes Councillors, Council staff members, committee members, consultants, contractors, suppliers, applicants, and volunteers who all have obligations in the prevention of fraud and corruption and the fostering of an ethical and accountable work environment at Council.

Expectations of this Plan and the related policy also apply to customers, community and any relevant third parties with regard to the functions and/or operations undertaken for or on behalf of Council.

OBJECTIVES OF THIS FRAUD AND CORRUPTION PREVENTION CONTROL PLAN

The primary objective of the plan is to protect resources, including information, and safeguard the integrity and reputation of Council.

The plan supports Council's Fraud and Corruption Prevention Policy and sets out the arrangements for the overall management of the risks and any instances of fraud and/or corruption.

The purpose of the plan is to:

- Provide an overview of the governance arrangements within Council relating to fraud and corruption control.
- Outline key fraud and corruption risk areas relevant to Council.
- Raise awareness of fraud and corruption risks, and thereby influence the culture of Council to encourage employees to be vigilant in responding to them.
- Communicate Council's expectation of management, employees, consultants/contractors, industry stakeholders, and service providers to assist prevent and detect fraud and corruption.
- Document fraud and corruption prevention, detection, and response initiatives adopted by Council to manage fraud and corruption.

PRINCIPLES

Council is committed to building a corruption resistant culture through:

- Promoting an organisational environment that encourages professionalism, integrity, and ethical conduct.
- Minimising the opportunity for fraudulent or corrupt conduct.
- The detection, investigation and disciplining and/or prosecuting fraudulent or corrupt conduct.
- The Reporting of any fraud or corrupt conduct to the Independent Commission Against Corruption (ICAC) and other authorities where appropriate.

Relevant Legislation

This Framework links with the following legislation:

- Local Government Act 1993
- Local Government (General) Regulation 2021
- Independent Commission Against Corruption Act 1988
- Public Interest Disclosures Act 2022

Relevant Council Policies and Documents

The following Council policies and procedures support this Plan:

- Fraud and Corruption Prevention Policy
- Code of Conduct
- Public Interest Disclosures Policy
- Secondary Employment Policy with Emergency Services Provision
- Related Party Disclosure Policy
- Acceptable Use Policy
- Code of Ethics – Council Contractors Policy

- Privacy Management Plan
- Procurement Policy
- Records Management Policy

References

- Audit Office of NSW – Fraud Control Improvement Kit February 2015
- Port Macquarie Hastings Council – Fraud and Corruption Prevention Control Plan 2021
- Liverpool Plains Shire Council - Fraud and Corruption Prevention Control Plan 2021
- Northern Beaches Council – Fraud and Corruption Control Plan 2019

DEFINITIONS

To assist in interpretation, the following definitions apply:

Term	Definition
Fraud	Dishonest activity causing actual or potential financial loss to any person or entity including theft of moneys or other property by employees or persons external to the entity and whether or not deception is used at the time, immediately before or immediately following the activity. This also includes the deliberate falsification, concealment, destruction, or use of falsified documentation used or intended for use for a normal business purpose or the improper use of information or position.
Corruption (or corrupt conduct)	As per the ICAC Act 1988 (Sect 7, 8, 9): <ul style="list-style-type: none"> • Any conduct of a person (whether or not a public official) that adversely affects, or could affect the honest and impartial exercise of public official functions, or • Any conduct of a public official that involves the dishonest or partial exercise of any of his or her public official functions, or • Any conduct of a public official or former public official that constitutes or involves a breach of public trust, or • Any conduct of a public official or former public official that involves the misuse of information or material that he or she has acquired in the course of his or her official functions, whether or not for his or her benefit or for the benefit of any other person.
Maladministration	As per Public Interest Disclosure Act 2022: Conduct that involves action or inaction of a serious nature that is contrary to law; or unreasonable, unjust, oppressive, improperly discriminatory; or based wholly or partly on improper motives. Refer Gwydir Shire Council Public Interest Disclosures Policy.
Serious or substantial waste	Refers to the uneconomical, inefficient, or ineffective use of resources, authorised or unauthorised, which results in a loss/wastage of public funds/resources.

Stakeholders	Stakeholders refer to Councillors, Council staff members, committee members, consultants, contractors, suppliers, applicants, and volunteers.
--------------	---

PLAN

Gwydir Shire Council is committed to a culture of good governance and ethical behaviour. As such, we will not tolerate fraudulent or corrupt behaviour and are committed to building a sound ethical culture supported by appropriate policies, procedures, and strategies that prevent fraudulent and corrupt behaviour through:

- Ongoing education and training of all Council officials in relation to their obligations in combating dishonest and fraudulent behaviour.
- Regular review of fraud and corruption risk assessments to identify circumstances where fraud and corruption could occur.
- Implementation of procedures that have regard to, and mitigate, the risks identified in day-to-day activity.
- Promote an organisational environment that encourages professionalism, integrity, and ethical conduct.
- Use of formal procedures upon detection, investigation, disciplining and/or prosecuting fraudulent or corrupt conduct.
- The reporting of any fraud or corrupt conduct to the Independent Commission Against Corruption (ICAC) and other authorities where appropriate.

Council’s commitment to preventing fraudulent or corrupt activity, and avoiding or managing conflicts of interests, will be supported by implementing appropriate auditing systems to deter and identify corrupt activities, included in the following Fraud Control Framework.

FRAUD CONTROL FRAMEWORK

In order to achieve best practice, Gwydir Shire Council is adopting the following processes which are sourced from the Fraud Control Framework of the Audit Office of NSW. The Audit Office framework is acknowledged as being best practice and widely used in State and Local Government organisations, providing for a consistent, effective, and systematic approach to preventing fraud and corruption across the organisation.

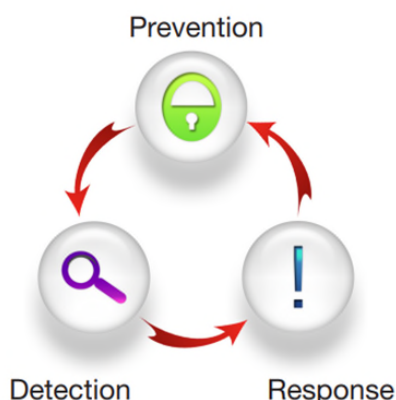

Audit Office of New South Wales | Fraud Control Improvement Kit | February 2015

The Fraud Control Framework of the Audit Office of NSW encompasses ten key attributes which sit within the themes of prevention, detection, and response. Each attribute has a checklist of high-level processes and behaviours that should be present.

Attribute	Theme
Attribute 1 - Leadership	Prevention
Attribute 2 - Ethical Framework	Prevention, Detection, Response
Attribute 3 - Responsibility Structures	Prevention, Detection, Response
Attribute 4 - Fraud and Corruption Prevention Policy	Prevention
Attribute 5 - Prevention Systems	Prevention
Attribute 6 - Fraud Awareness	Prevention, Response
Attribute 7 - Third Party Management Systems	Prevention, Response
Attribute 8 - Notification Systems	Detection, Response
Attribute 9 - Detection Systems	Detection
Attribute 10 - Investigation Systems	Response

PREVENTION

1 LEADERSHIP

A successful fraud control framework is led by a committed and accountable **Executive Team** who demonstrate and reinforce the high ethical standards expected of public officials, who are resistant to improper behaviour or practice, and promote an open culture of accountability and transparency. The General Manager has ultimate responsibility for fraud and corruption prevention within Council and is supported by the **Executive Team; Audit, Risk and Improvement Committee; and the Governance function.**

2 ETHICAL FRAMEWORK

The Fraud and Corruption Prevention Control Plan, related Policy, and associated framework builds upon Gwydir Shire Council's commitment to ethical, transparent, and accountable behaviour. Gwydir Shire Council has clear policies, such as its Code of Conduct, setting out acceptable standards of ethical behaviour which are available to all staff on **Council's intranet and website**. Council also provides regular training in the Code of Conduct as well as provide sessions during new staff inductions and new committee formation on the requirements of the code.

3 RESPONSIBILITY STRUCTURES

This Plan applies to everyone who has any interaction with Council or Council staff to the maximum extent that Council has the authority to require it. This includes Councillors, Council staff members, committee members, consultants, contractors, suppliers, applicants, and volunteers who all have obligations in the prevention of fraud and corruption and the fostering of an ethical and accountable work environment at Council.

Expectations of this Plan also apply to customers, community, and any relevant third parties with regard to the functions and/or operations undertaken for or on behalf of Council.

3.1 All Staff

It is important that all Council staff contribute to a workplace culture that has a 'zero tolerance' approach towards fraudulent and corrupt behaviour. As such, all staff have responsibilities in accordance with this Plan, specifically:

- Maintain awareness and compliance with the requirements of the Plan and the related policy.
- Perform their duties to the best of their abilities with honesty, integrity, and impartiality.
- Have regard to fraud and corruption related risks when performing their duties, and support processes that report and mitigate risks.
- Prevent, mitigate, and report on (suspected, actual, or attempted) fraud, corruption, maladministration, and waste. This shall be done in accordance with Council's Code of Conduct and Public Interest Disclosures Policy.
- Cooperate with and provide assistance to investigators or officials investigating suspected or reported fraud or corruption.
- Manage and declare pecuniary and non-pecuniary interests in compliance with Council's Code of Conduct.

3.2 General Manager

The General Manager is responsible for the efficient and effective operation of Council and the implementation of systems and practices that proactively minimise risks of fraud and corruption while promoting an ethical workplace culture that has 'zero tolerance' towards fraudulent and corrupt behaviour and is readily reported should it occur.

In addition to the responsibilities of all staff, the General Manager is required to:

- Promote Council's commitment to fraud and corruption prevention.
- Lead by example through ethical workplace behaviour, decision making, acting with honesty, integrity, and impartiality when dealing with others.
- Ensure processes exist to monitor **Directors' and Managers'** compliance with their duties in accordance with this Plan and the related policy.
- Ensure Councillors are aware of their obligations in accordance with this Plan.
- Monitor and review fraud and corruption risk assessments on a regular basis.
- Ensure any allegations of wrongdoing are fully investigated and report actual or suspected corrupt conduct to the Independent Commission Against Corruption (ICAC) in accordance with **Section 11 of the ICAC Act 1988.**
- Report criminal offences to the NSW Police Force.

3.3 Mayor and Councillors

Responsibilities in accordance with this Plan and the related policy, specifically:

- Maintain awareness and compliance with the requirements of the Plan and the related policy.
- Perform their duties to the best of their abilities with honesty, integrity, and impartiality.
- Consider fraud and corruption related risks when performing their duties, and support processes that report and mitigate risks.
- Prevent, mitigate, and report on (suspected, actual, or attempted) fraud, corruption, maladministration, and waste. This shall be done in accordance with Council's Code of Conduct and Public Interest Disclosures Policy.
- Cooperate with and provide assistance to investigators or officials investigating suspected or reported fraud or corruption.
- Reporting all instances of possible fraud or corrupt conduct, in accordance with Council's Code of Conduct and Public Interest Disclosures Policy.
- Provide support to the General Manager to implement adequate strategies to prevent fraud and corruption.
- Implementing and promoting Council's commitment to fraud and corruption prevention.
- Manage and declare pecuniary and non-pecuniary interests in compliance with Council's Code of Conduct.

3.4 Directors and **Group** Managers

- In addition to the general responsibilities of all staff, Directors and Managers have a supervisory role in the implementation of this Plan and promotion of an ethical workplace culture by demonstrably supporting the objectives of this Plan and the related policy, specifically:
 - Leading by example through ethical workplace behaviour, decision making, acting with honesty, integrity, and impartiality when dealing with others.
 - Promoting and disseminating of this Plan and the related policy and the standards of ethical behaviour expected by Council.
 - Ensure training is provided to employees surrounding fraud and corruption awareness, Council's expectations, and the reporting requirements in accordance with Council's Code of Conduct and Council's Public Interest Disclosures Policy.
 - Provide ethical advice and support to staff.

- Identify and ensure appropriate internal controls are in place to manage potential fraud and corruption risks. This includes systematic review of risks and controls over time as well as initial identification, and assessment of training needs including refresher training.

3.5 Governance Officer

In addition to the general responsibilities of all staff, the **Governance Officer** is Council's Disclosures Coordinator for the purpose of Council's Public Interest Disclosures Policy. This role is further responsible for the provision of advice and education surrounding fraud and corruption prevention, Council's expectations, and reporting requirements in accordance with Council's Code of Conduct and Public Interest Disclosures Policy.

The Group Manager Governance may also initiate investigations into allegations of wrongdoing.

3.6 Audit, Risk, and Improvement Committee (ARIC)

The ARIC provides independent assistance to the Council by providing advice on the adequacy of the fraud control framework and the processes and systems in place to capture and effectively manage the identified fraud and corruption risks, internal controls, and proposed risk treatment action plans which will be documented and recorded in **Council's Risk Register**.

The responsibilities of the ARIC are set out in the **ARIC Charter** as resolved by Council. These responsibilities include:

- Compliance
- Risk Management
- Fraud Controls
- Financial Management
- Governance
- Implementation of the **Community Strategic Plan, Delivery Program, and Strategies**
- Service Reviews and Performance Measurement
- Performance of Council Functions
- Internal Audit
- External Audit

3.7 Volunteers and Contractors acting for Council

Volunteers and Contractors providing services or otherwise acting on behalf of Council are required to:

- Perform their duties to the best of their abilities with honesty, integrity, and impartiality.
- Consider fraud and corruption related risks when performing their duties, and support processes that report and mitigate risks.
- Prevent, mitigate, and report on (suspected, actual, or attempted) fraud, corruption, maladministration, and waste. This shall be done in accordance with Council's Code of Conduct and Public Interest Disclosures Policy.

- Cooperate with and provide assistance to investigators or officials investigating suspected or reported fraud or corruption.

3.8 External Parties

Council requires that all external parties act ethically and honestly in their business dealings with Council and that:

- Actual or perceived conflicts of interest are declared at the point any conflict becomes apparent.
- Any persons doing business with Council are to provide accurate and reliable information to Council when required.
- Take all preventative measures to prevent the unauthorised disclosure of confidential Council information.

External parties include Contractors, Consultants, Suppliers, Applicants, other Government Agencies, or any other party engaged in business dealings with Council.

3.9 Residents and Members of the Public

Council encourages residents, customers, and members of the public to support Council in preventing and responding to fraudulent or corrupt behaviour and invites those who suspect fraud or corruption that involves Council, to report their suspicions to the General Manager, **Governance Officer**, or any other appropriate authority.

4 KEY FRAUD AND CORRUPTION RISKS FACING COUNCIL

The table below provides a summary of the key fraud and corruption risks facing Council. This is not an exhaustive list. Details of Council’s fraud and corruption risks will be included in **Council’s fraud and corruption functional risk register**.

Risk Category	Description	Risk Attributes
Corruption		
Conflicts of Interest	A conflict of interest occurs when an employee or agent – someone who is authorised to act on behalf of a principal – has an undisclosed personal or economic interest in a matter which could influence their professional role	Extent and value of supplier relationships / contracts Extent of recruitment activities / staff turnover Presence of decentralised procurement and recruitment systems
Bribery, Illegal Gratuities, Economic Extortion	Bribery is offering, promising, giving, accepting, or soliciting an advantage as an inducement for an action which is illegal or unethical. Illegal gratuities are items of value given to reward a decision after it has been made. They do not necessarily involve intent. Extortion is the obtaining of property	Number of staff Number of supplier and contractor relationships

	from another, with the other party's consent, induced by wrongful use of actual or threatened force or fear	
Asset Misappropriation		
Theft of Cash	A scheme in which an employee steals or misuses the employing organisation's resources	Use of petty cash Turnover of cash
Inventory and all Other Assets	A scheme in which an employee steals or misuses the employing organisation's resources	Nature of assets (data, inventory, fixed assets)
Fraudulent Disbursements	A scheme in which an employee causes their employer to issue a fraudulent payment for fictitious goods or services, or reimbursement of fraudulent expenses	Volume and value of supplier transactions Volume and value of expense transactions
Financial Statement Fraud		
Net Worth / Net Income Understatements / Overstatements	A scheme in which an employee intentionally causes a misstatement or omission of material information in the organisation's financial reports	Change in management, high turnover of executive members Significant pressure from stakeholders to reduce costs and improve financial results Financial position of the organisation

5 PREVENTION SYSTEMS

Council's main objective is to minimise the occurrence of fraud and corruption within Council. This objective will be achieved by:

- Identifying fraud and corruption risks
- Determining strategies to control those risks
- Defining responsibility and timeframes for strategies to be implemented

Council's identified fraud and corruption risks, internal controls, and proposed risk treatment action plans will be documented and recorded in **Council's Risk Register**.

Council recognises that internal audit complements the internal assessment of fraud and corruption related risks and controls. Independent identification and assessment of Council's fraud and corruption risks will be arranged through independent auditors to the extent that the Audit, Risk, and Improvement Committee (ARIC) deems warranted.

6 FRAUD AWARENESS

One of the most common ways in which fraud and corruption is detected is by observation, investigation, and reporting by those who work with, or deal directly with, the perpetrator(s).

Council will commit to providing all staff with a general awareness of fraud and corruption and provide guidance on how they are to respond if such behaviour is suspected, detected, or attempted.

This will be achieved in a number of ways by:

- Incorporating a brief session on fraud and corruption prevention into induction training for new staff
- Providing fraud awareness training sessions to Management and staff
- Making the Code of Conduct and the Fraud and Corruption Prevention Policy available to all staff and the general public via [Council's website](#)
- Disseminating articles of interest on fraud and corruption to staff via staff newsletters, publications, and circulars
- Promotion of this plan and associated documents through Council's procurement framework and procurement documentation
- Introduction of a "whistleblower hotline" to allow members of staff and the community to report inappropriate behaviours such as (but not limited to) corrupt conduct, maladministration, or alleged fraud. This will provide for public interest disclosures to be reported as well as anonymous reports
- Regular attendance at relevant industry forums and seminars

Additionally, Council routinely interacts with a wide range of stakeholders such as residents, ratepayers, suppliers, contractors, developers, volunteers, applicants, media, community organisations, and various other interested parties. There is a need to ensure that these stakeholders are actively aware of Council's attitude towards fraud and corruption and that such behaviour will not be tolerated, through the promotion of this plan in an effort to reduce the likelihood of improper dealings and/or attempts by external parties to influence Councillors or Council staff.

7 THIRD PARTY MANAGEMENT SYSTEMS

Gwydir Shire Council ensures that appropriate controls are in place via an assortment of policies to manage our dealings with third parties and conflicts of interest. In doing so we make available a copy of our [Statement of Business Ethics](#) to contractors and suppliers to ensure understanding of the standards of behaviour expected by Council.

Third party management also covers managing staff conflicts of interest in accordance with Council's Code of Conduct, Related Party Disclosure Policy, and secondary employment declaration requirements in accordance with Section 353 Local Government Act 1993.

8 NOTIFICATION SYSTEMS

Council's Code of Conduct compels all employees to report any instances of possible fraud, corruption, maladministration, or serious and substantial wastage. Members of the public are actively encouraged to report any such behaviour that is known or suspected. Council supports and encourages a supportive culture of reporting and any person who makes a report in accordance with Gwydir Shire Council's Public Interest Disclosures Policy will be protected under the Public Interest Disclosures Act 2022.

As previously mentioned, Council will be introducing a “whistleblower hotline” to allow members of staff and the community to report inappropriate behaviours such as (but not limited to) corrupt conduct, maladministration, or alleged fraud. This will provide for public interest disclosures to be reported as well as anonymous reports.

Reports of all suspected unethical activity including corruption be made to Council’s Governance Officer. Alternatively, anyone wishing to make a report can direct matters of corruption to the Independent Commission Against Corruption, maladministration to the NSW Ombudsman, and serious and substantial wastage to the Office of Local Government.

9 DETECTION SYSTEMS

Internal controls are effective at detecting fraudulent and corrupt behaviour with Council maintaining appropriate controls such as:

- Segregation of duties
- Approvals and authorisation
- Verification
- Reconciliations
- Management reviews
- Data mining tools
- Risk assessments
- Physical security
- Job rotation
- Independent reviews like internal and external audits and peer reviews
- Audit, Risk, and Improvement Committee

Council will not tolerate any reprisal action against staff who uncover and report such behaviour and will ensure appropriate methods are in place for their protection. If someone believes that detrimental action has been or is being taken against them, or someone else who has reported suspected fraud or corruption, they should advise a disclosure officer in accordance with the Public Interest Disclosures Policy immediately.

10 INVESTIGATION SYSTEMS

10.1 Assessment

When an allegation of fraud or corruption is made under a Public Interest Disclosure, the Disclosures Coordinator will undertake a preliminary assessment and may recommend that the matter be referred to an external body or that a full investigation be conducted. The complainant will be advised, and action taken as appropriate in accordance with Council’s Public Interest Disclosures Policy.

10.2 Support

Council will deal fairly with all parties in the course of investigating allegations of fraud or corruption, however if fraud or corruption is proven, Council will apply the appropriate sanctions or refer the matter to external law enforcement agencies if criminal offending is detected.

Council's investigation standards are clearly documented in various Council policies and procedures that include Council's Code of Conduct, Public Interest Disclosures Policy, and **Workplace Investigations Policy and Procedure**.

10.3 Maintaining Confidentiality

Every effort will be made to ensure that any allegations of fraudulent or corrupt conduct are handled confidentially. In some situations, confidentiality may not be possible or appropriate and will be managed in accordance with the Public Interest Disclosures Policy.

Council will accept and consider anonymous reports; however, anonymity may limit Council's ability to seek further information or adequately assess the report.

10.4 Vexations, Frivolous or Misleading Allegations

Any report that is found to be vexatious, frivolous, or deliberately misleading may result in disciplinary action against the staff member for making the allegation.

REVIEW

This plan will be reviewed every 12 months.

Appendix 1 - Examples of Potential Fraudulent and Corrupt Activity**Theft**

The most common types of property stolen include:

- Stationery and office supplies
- Construction and maintenance equipment and tools
- Lap top computers
- Mobile phones
- Technical equipment
- Cash
- Fuel
- Intellectual property, including documents and data

Theft also includes the unauthorised use of credit cards, petrol cards, Cabcharge cards or vouchers.

Gifts, Benefits and Bribes

Gifts, benefits, and bribes are often intended to influence the way the recipient carries out official functions. The intention may be to encourage the recipient to not look too closely at an illegal or unauthorised activity, or to actively participate in a fraudulent or corrupt activity.

Exposure to offers of gifts, benefits or bribes is particularly common for Council Officers who:

- Approve or can influence decisions
- Procure goods or services
- Carry out regulatory work
- Provide customer or client service
- Carry out work with the private sector

Misuse of Council Resources for Inappropriate Private Purposes

In their publication "Preventing the misuse of Council Resources Guideline 2", the ICAC provides a number of examples of this type of risk:

- A Council driver using a Council truck to deliver tonnes of gravel to a friend's property and remove a tree
- A works team undertakes paid work for a builder on a construction site during working hours
- A swimming pool manager running a non-authorised swimming school during work hours
- A parks maintenance officer running a landscaping business using council equipment and materials, and falsifying timesheets to cover up his private use
- Five council employees spend a workday turfing an employee's backyard

Other forms of misuse include:

- Staff using mobile phones excessively for private purposes without reimbursement of costs
- Internet services being used extensively for non-work purposes

- “Left-over” materials and low value assets being claimed by Council Officers

Zoning and Development

- Coercion, intimidation, and harassment of Council planners dealing with development applications
- Inducements from developers to modify approved DA or conditions imposed

Regulatory Compliance

- Compliance Officers accepting bribes and favours to allow illegal and unauthorised activities

Procurement, Tendering, and Contract Management

Activities associated with procurement, tendering and contract management have traditionally been very susceptible to fraud and corruption. They normally result from bribes, commissions, or conflicts of interests. Examples of the type of fraud and corruption risk exposures include:

- Order splitting to avoid tendering or obtaining quotes
- Collusion with suppliers to provide dummy quotes
- Accepting late tenders without justification
- Approving fraudulent contract variations

Human Resources

- Creation of fictitious employees on the payroll register
- Applicants for positions falsifying career background details
- Direct recruitment of friends and relatives to permanent and casual positions

Delegations

The opportunity for various types of fraud and corruption can be increased by:

- Unclear delegations
- Delegation for order and payment granted to same person
- Lack of supporting documentation

Information Technology

The main risk areas of computer fraud are:

- Unauthorised electronic transfer of funds
- Electronic claims processing
- Unauthorised alteration of input data
- Misappropriation, destruction, or suppression of output data

- Alteration of computerised data
- Alteration or misuse of software program

Forgery or Falsification of Records

The falsification of records and processing of a false statement is fraud. Examples include falsification of:

- Data on expense claims and receipts
- Credit card reimbursement claims
- Invoices and timesheets
- Job application forms
- Leave records
- Forgery of a signature on a cheque or document
- Unauthorised use of an electronic signature

Unauthorised Sale or Provision of Information

This risk involves unauthorised sale or provision of confidential information, including client information.

Appendix 2 – Reporting Fraud and Corruption

A staff member who suspects that fraudulent activity is occurring should observe the following steps:

1. Note observations:

- Do not jump to conclusions
- Carefully observe and note the suspected conduct
- Document your own actions
- Keep any documents as possible evidence and do not alter them, e.g. by marking, and ensure they are stored securely

2. Report concerns:

- To your Manager or a Disclosure Officer who is available to provide advice on a confidential basis.

3. Inform only those who need to know:

- To prevent possible destruction of evidence by those involved in the fraud
- As protection against any pressure from those at the centre of the allegations

4. Maintain confidentiality:

- To protect the rights of a person suspected of fraudulent activity who may in fact be innocent

A report of wrongdoing can be made in writing or verbally:

- To your Supervisor or Manager
- To a Disclosure Officer – as listed on the Public Interest Disclosures Policy
- Through Council's hotline where you may make an anonymous report

Additionally, the following external agencies are able to provide advice or take reports of wrongdoing at Local Councils:

Independent Commission Against Corruption (ICAC) – about alleged corruption

(ICAC) Telephone: 1800 463 909
Address: GPO Box 500, Sydney NSW 2001
Email: icac@icac.nsw.gov.au

Office of Local Government – about serious and substantial waste

Telephone: (02) 4428 4100
Email: olg@olg.nsw.gov.au

NSW Ombudsman – about alleged maladministration

Telephone: 1800 451 524
Address: 580 George Street, Sydney NSW 2000

Information and Privacy Commission NSW – about alleged information breaches

Telephone: 1800 472 679
Email: jpcinfo@ipc.nsw.gov.au

Appendix 3 – NSW Audit Office Fraud Control Checklist

Resource one: Fraud control checklist

Attribute 1: Leadership

1. CEO and senior management commitment to fraud control:
 - CEO visibly endorses fraud control activities
 - senior managers demonstrate their commitment to mitigate fraud risks.
2. Clearly defined CEO and senior management accountability and responsibility:
 - senior management assigned responsibility for implementing the fraud control framework
 - senior managers' individual performance agreements contain performance measures and indicators relating to successful fraud control.

Attribute 2: Ethical framework

3. Clear policies setting out acceptable standards of ethical behaviour:
 - staff have easy access to all ethical behaviour policies
 - ethical behaviour policies are included in the induction process.
4. Demonstrated compliance with the ethical framework:
 - staff annually evidence their commitment to acceptable standards of behaviour.
5. Employees can articulate obligations to ethical behaviour and the organisation's position on fraud:
 - staff understand fraud is not tolerated and the consequences of committing fraud.

Attribute 3: Responsibility structures

6. Management and all staff have clearly defined responsibilities for managing fraud:
 - staff are aware of the responsibility structure in the organisation
 - responsibilities for fraud control are contained in role descriptions, where appropriate.
7. Fraud management is integrated with core business:
 - managing fraud risks included in business plans.
8. Resources are allocated to managing fraud.
 - fraud committee established and/or a Fraud Prevention Manager appointed.
9. Clearly defined roles for audit and risk committee and auditors:
 - proactive and influential audit and risk committee
 - internal audit work covers controls over high risk fraud areas.
10. Staff with responsibility for fraud control and staff in high risk fraud areas are provided with training:
 - refresher and knowledge update training are provided on an ongoing basis
 - training program is integrated within a wider education and awareness campaign.

Attribute 4: Fraud control policy

11. Risk-based policies appropriate to the organisation:

- appropriate policies address the level and nature of internal and external fraud risks
- fraud control policy addresses the ten attributes of fraud control.

12. Holistic and integrated:

- fraud control policy does not operate in isolation and has strong links to other ethical behaviour policies.

13. Regularly reviewed, current and implemented:

- fraud control policy is responsive to changes in the operating environment and reviewed at least every two years.

Attribute 5: Prevention systems

14. Proactive and integrated fraud risk assessment:

- fraud risk assessment is part of organisation's enterprise risk management process
- risk assessment reviewed after substantial change and at least every two years.

15. Planning, follow up and accountability:

- fraud control plan in place and outcomes reported to senior managers and audit and risk committee.

16. Analysis of and reporting on suspected and actual frauds:

- fraud database established containing all reports of fraud, action taken and outcomes
- database kept up to date and published on website.

17. Ethical workforce:

- pre-employment screening.

18. IT security strategy:

- specific IT security strategy aligned with the organisation's business strategy
- cybercrime included as a risk on the risk register.

Attribute 6: Fraud awareness

19. Comprehensive staff education and awareness program:

- ongoing ethical behaviour and fraud education and awareness program
- fraud control message repeated and reinforced using a variety of communication channels
- fraud control expectations included in the induction process
- staff have a good understanding of what fraud is
- guidance material deals with real life situations, conflicts and fraud risks staff face in their work area.

20. Staff awareness of fraud control responsibilities:

- staff have a good appreciation and understanding of their responsibilities for preventing, detecting and reporting fraud.

21. Customer and community awareness:

- publicity campaigns developed where appropriate
- customers and the community encouraged to report suspicions of fraud and provided with easy to use channels to make reports
- customers and the community have confidence in the integrity of the organisation
- statement of business ethics setting expectations and mutual obligations.

Attribute 7: Third party management systems

22. Targeted training and education for key staff:

- targeted training and education programs for staff with responsibilities for dealing with third parties.

23. Third party due diligence and clear contractual obligations and accountabilities:

- structured risk-based due diligence before engaging contractors or third parties
- contracts and service level agreements include clear accountabilities for managing the risk of fraud
- position descriptions for staff with responsibilities for managing third parties include accountabilities for managing fraud risks.

24. Effective third party internal controls:

- specific internal controls relating to third parties in place
- checks and reviews carried out on dealings with third parties.

25. Third party awareness and reporting:

- contractors and suppliers understand organisation will not tolerate corruption including fraudulent dealings
- statement of business ethics setting expectations and mutual obligations
- reporting mechanisms established for reporting suspected fraud
- contractors and suppliers encouraged to provide information if they suspect fraud is occurring.

26. Staff disclosure of conflicts of interest and secondary employment:

- staff regularly required to disclosure conflicts of interest and secondary employment
- records of conflicts of interest and secondary employment reviewed and kept up-to-date.

Attribute 8: Notification systems

27. Culture that supports staff reporting fraud and management acting on those reports:

- well-publicised options for staff to report fraud
- staff feel confident they will be protected from reprisal action
- demonstrated action taken in response to reports of fraud.

28. Policies, systems and procedures that support reporting:

- reporting system appropriate to organisation
- different channels available to report fraud
- feedback and follow-up with internal reporters.

29. Processes to support upward reporting:

- actual and suspected frauds reported to CEO and audit and risk committee
- fraud database published on organisation's website.



30. External reporting:

- staff are clear on policy and procedures for external reporting
- external reporting in accordance with legislation and policy
- clear and consistent approach to external reporting.

Attribute 9: Detection systems

31. Robust internal controls:

- well documented risk-based internal controls
- routine checks of activities, processes controls and transactions
- range of internal controls that 'prevent, detect and correct'.

32. Monitoring and review:

- available data monitored and reviewed to ensure irregularities and warning signals are picked up early
- early warning signs acted on quickly and red flag behaviour recognised.

33. Risk-based internal audit program:

- internal audit program evaluates the potential for fraud and how fraud risk is managed
- internal audit recommendations assigned to individuals with timeframes for response.

Attribute 10: Investigations systems

34. Clear documented investigation procedures:

- reports of fraud investigated promptly and to the highest standards
- investigations are independent
- sufficient resources allocated, including budget.

35. Investigations conducted by qualified and experienced staff:

- investigations conducted by appropriately qualified personnel with recognised qualifications and appropriate experience.

36. Decision-making protocols:

- documented decision-making processes
- proportionate responses to incidents of fraud.

37. Disciplinary systems:

- staff understand fraud will not be tolerated and the perpetrators will face disciplinary action
- commitment to taking action against the perpetrators of fraud
- consistent application of sanctions.

38. Insurance:

- consider a fidelity guarantee insurance policy to protect against the financial consequences of fraud.

9.9 Quarterly Financial Review - March 2024

File Reference: NA

Delivery Program

Goal: 5. Organisational management

Outcome: 5.1 Corporate management

Strategy: 5.1.1 Financial Management and accountability systems

Author: CFO

STAFF DISCLOSURE OF INTEREST Nil

IN BRIEF/SUMMARY RECOMMENDATION

This report recommends the adoption of the March.

TABLED ITEMS Nil

BACKGROUND

This report is required under the Local Government Act and associated Regulations.

COMMENT

The commentary in this report is directed at overall results. The impact on individual business units and by implication the associated service levels has not been assessed - this is the responsibility of individual directors and managers.

The March Quarterly Review has been completed with the best information available the time of preparation to best reflect the expected position of Council at the end of the financial year.

Council continues to maintain a good financial position that is constantly being monitored as the significant delays in receiving grant funding payments can alter Council's position significantly.

STATUTORY ENVIRONMENT

Local Government Act 1993 and associated regulations. A quarterly budget review is due within 2 months of the end of each quarter under the requirements of Clause 203 of the Local Government (General) Regulation 2005:

203 Budget review statements and revision of estimates

1. Not later than 2 months after the end of each quarter, the responsible accounting officer of a council must prepare and submit to the council a budget review statement that shows, by reference to the estimate of income and expenditure set out in the management plan that the council has adopted for the relevant year, a revised estimate of the income and expenditure for that year.

2. A budget review statement must include or be accompanied by:

1. a report as to whether or not the responsible accounting officer believes that the statement indicates that the financial position of the council is satisfactory, having regard to the original estimate of income and expenditure, and

2. if that position is unsatisfactory, recommendations for remedial Action.

3. A budget review statement must also include any information required by the Code to be included in such a statement.

OFFICER RECOMMENDATION

THAT the March Quarterly Budget Review Statement be noted.

FURTHER that the March Quarterly Budget adjustments be approved.

ATTACHMENTS

1. Quarterly Budget Review Statement Jan to March 2024 [9.9.1 - 9 pages]

COUNCIL RESOLUTION:

THAT the March Quarterly Budget Review Statement be noted.

FURTHER that the March Quarterly Budget adjustments be approved.

(Moved Cr Egan, Seconded Cr Smith)

CARRIED

For: Cr J Coulton, Cr Egan, Cr D Coulton, Cr Galvin, Cr Matthews, Cr Moore, Cr Mulligan and Cr Smith

Against: Nil

Gwydir Shire Council

Quarterly Budget Review Statement
for the period 01/01/24 to 31/03/24

Table of Contents	page
1. Responsible Accounting Officer's Statement	1
2. Income & Expenses Budget Review Statement's Statement	2
Recommended Changes	3
3. Capital Budget Review Statement Statement	4
Recommended Changes	5
4. Cash & Investments Budget Review Statement Statement	6
5. Contracts & Other Expenses Budget Review Statement	7
6. Consultancy & Legal Expenses Budget Review Statement	8

Gwydir Shire Council

Quarterly Budget Review Statement

for the period 01/01/24 to 31/03/24

Report by Responsible Accounting Officer

The following statement is made in accordance with Clause 203(2) of the Local Government (General) Regulations 2005:

31 March 2024

It is my opinion that the Quarterly Budget Review Statement for Gwydir Shire Council for the quarter ended 31/12/23 indicates that Council's projected financial position at 30/6/24 will be satisfactory at year end, having regard to the projected estimates of income and expenditure and the original budgeted income and expenditure.

Signed: 

date: 20th May 2024

Helen Thomas
Responsible Accounting Officer

Quarterly Budget Review Statement
for the period 01/01/24 to 31/03/24

Gwydir Shire Council
Income & Expenses Budget Review Statement

Budget review for the quarter ended 30 September 2023
Income & Expenses - Council Consolidated

	Original Budget				Approved Changes				Carry Forwards	Other than QBRs	Revised Budget 2023/24	Variations for this Mar Ctr	Notes	Projected Year End Result	Actual YTD figures
	2023/24	2023/24	2023/24	2023/24	2023/24	2023/24	2023/24	2023/24							
Income	(8,702,233)	-	(2,961,125)	-	(11,663,358)	(274,475)				(11,937,833)	(11,937,833)			(12,002,556)	
Rates and Annual Charges	(2,350,705)	-	(1,995)	(1,995)	(3,594,333)	337,780				(3,256,553)	(3,256,553)			(5,569,707)	
User Charges and Fees	(42,000)	-	(300,000)	-	(342,000)	(300,000)				(642,000)	(642,000)			(629,479)	
Interest and Investment Revenues	(7,887,418)	-	(208,342)	-	(8,095,760)	(2,652,576)				(10,748,336)	(10,748,336)			(856,599)	
Other Revenues	(13,506,895)	-	(592,180)	(592,180)	(16,107,612)	(5,285,027)				(21,402,639)	(21,402,639)			(14,967,174)	
Grants & Contributions - Operating	(36,229,664)	-	2,452,590	-	(33,777,074)	5,735,924				(28,041,150)	(28,041,150)			(10,743,002)	
Grants & Contributions - Capital	-	-	-	-	-	-				-	-			(146,514)	
Net gain from disposal of assets	-	-	-	-	-	-				-	-			-	
Transfer from Reserves	-	-	-	-	-	-				-	-			-	
Total Income from Continuing Operations	(68,718,915)	-	(4,267,047)	(4,267,047)	(73,580,137)	(2,448,374)				(76,028,511)	(76,028,511)			(44,915,031)	
Expenses	13,559,825	-	623,174	-	14,182,999	1,602,750				15,785,749	15,785,749			11,677,416	
Employee Costs	95,200	-	348,000	-	443,200	-				443,200	443,200			431,858	
Borrowing Costs	50,289,526	-	854,425	-	11,256,339	1,746,325				13,002,664	13,002,664			10,301,699	
Materials & Contracts	7,766,685	-	2,200,000	-	9,966,685	-				9,966,685	9,966,685			7,434,456	
Depreciation	5,000	-	-	-	5,000	-				5,000	5,000			8,832	
Legal Costs	593,000	-	-	-	593,000	-				593,000	593,000			181,822	
Consultants	3,037,284	-	23,991	(18,234)	3,043,041	645,823				3,688,864	3,688,864			2,892,682	
Other Expenses	-	-	-	-	-	-				-	-			-	
WIP	-	-	-	-	-	-				-	-			-	
Net Loss from disposal of assets	-	-	-	-	-	-				-	-			-	
Total Expenses from Continuing Operations	75,346,520	-	1,226,416	3,058,028	79,645,964	7,683,762				83,645,862	83,645,862			14,911	
Net Operating Result from Continuing Operations	6,627,605	-	632,241	(1,209,019)	6,065,827	5,235,388				7,617,351	7,617,351			18,596,709	
Discontinued Operations - Surplus/(Deficit)	-	-	-	-	-	-				-	-			-	
Net Operating Result from All Operations	6,627,605	-	632,241	(1,209,019)	6,065,827	5,235,388				7,617,351	7,617,351			18,596,709	
Net Operating Result before Capital Items	42,857,269	-	632,241	(3,661,609)	39,842,901	(600,536)				35,656,501	35,656,501			28,399,711	

Gwydir Shire Council

Quarterly Budget Review Statement
for the period 01/01/24 to 31/03/24

Income & Expenses Budget Review Statement
Recommended changes to revised budget

Budget Variations being recommended include the following material items:

Notes	Details
User Charges and Fees	Decrease in line with projections for end of year.
Interest and Investment	Increase in line with bank interest and expected income for the financial year
Operating Grants	Regional Emergency Roads Funding
Capital Grants	Fixing Country Roads Grant adjustment
Employee Costs	Adjustment in line with expected expenditure for the year
Materials and Contracts	Capital Projects adjustment over several areas
Depreciation	Adjustment in line with depreciation figure after End of Year processes complete

Quarterly Budget Review Statement
for the period 01/01/24 to 31/03/24

Gwydir Shire Council
Capital Budget Review Statement

Budget review for the quarter ended 30 September 2023
Capital Budget - Council Consolidated

	Original Budget 2023/24	Carry Forwards	Other than by QBRs	Approved Changes				Revised Budget 2023/24	Variations for this Dec Qtr	Notes	Projected Year End Result
				QBRs	Dec QBRs	Sep QBRs	Mar QBRs				
Capital Expenditure											
New Assets											
- Plant & Equipment	4,000,000	-	-	260,000			4,000,000			4,000,000	
- Land & Buildings							260,000			260,000	
- Other											
Renewal Assets (Replacement)											
- Plant & Equipment	1,500,000						1,500,000			1,500,000	
- Land & Buildings	1,700,000			633,000			2,933,000			2,933,000	
- Roads, Bridges, Footpaths	29,530,936			(1,791,826)			27,739,110	(5,735,924)		22,003,186	
Materials	-						-			-	
Loan Repayments (Principal)	-						-			-	
Waste	-						-			-	
Water supply	692,500						692,500			692,500	
Sewerage services	2,965,000						2,965,000			2,965,000	
Total Capital Expenditure	40,388,436	-	-	(898,826)		600,000	40,089,610	(5,735,924)		34,353,686	
Capital Funding											
Rates & Other United Funding	550,772					300,000	850,772			850,772	
Capital Grants & Contributions	36,229,664						35,330,838	(5,735,924)		29,594,914	
Reserves:											
- External Restrictions/Reserves	-						-			-	
- Internal Restrictions/Reserves	-						-			-	
New Loans											
Receipts from Sale of Assets											
- Plant & Equipment	300,000					300,000	600,000			600,000	
Waste	-						-			-	
Water supply	343,000						343,000			343,000	
Sewerage services	2,965,000						2,965,000			2,965,000	
Total Capital Funding	40,388,436	-	-	(898,826)		600,000	40,089,610	(5,735,924)		34,353,686	
Net Capital Funding - Surplus/(Deficit)	-	-	-	-	-	-	-	-	-	-	-

Gwydir Shire Council

Quarterly Budget Review Statement
for the period 01/01/24 to 31/03/24

Capital Budget Review Statement
Recommended changes to revised budget

Budget Variations being recommended include the following material items:

Notes	Details
Roads	Fixing Country Roads project

Quarterly Budget Review Statement
for the period 01/01/24 to 31/03/24

Gwydir Shire Council

Cash & Investments Budget Review Statement

Budget review for the quarter ended 30 September 2023

Cash & Investments - Council Consolidated

(\$'000's)	Original Budget 2023/24	Approved Changes				Revised Budget 2023/24	Variations for this Sep Qtr	Notes	Projected Year End Result	Actual YTD figures
		Carry Forwards	Other than QBRs	Sep QBRs	Dec QBRs					
Externally Restricted ⁽¹⁾										
Aged Care Bonds	625,000	-	-	-	625,000	-		625,000	569,000	
Developer Contributions	700,000	-	-	-	700,000	-		700,000	805,896	
Water	1,200,000	-	-	-	1,200,000	-		1,200,000	1,268,895	
Sewer	4,000,000	-	-	-	4,000,000	-		4,000,000	1,458,815	
Domestic Waste Management	4,200,000	-	-	-	4,200,000	-		4,200,000	4,627,477	
Contracted Liabilities	10,000,000	-	-	-	10,000,000	-		10,000,000	6,724,973	
Total Externally Restricted	20,725,000	-	-	-	20,725,000	-		20,725,000	15,455,056	
(1) Funds that must be spent for a specific purpose										
Internally Restricted ⁽²⁾										
Employee Leave Entitlement	900,000	-	-	-	900,000	-		900,000	1,000,000	
Trust Accounts	60,000	-	-	-	60,000	-		60,000	1,801,947	
Grant Funding	-	-	-	-	-	-		-	8,020,578	
Total Internally Restricted	960,000	-	-	-	960,000	-		960,000	10,822,525	
(2) Funds that Council has earmarked for a specific purpose										
Unrestricted (ie. available after the above Restricti	3,315,000	-	-	-	3,315,000	-		3,315,000	3,856,388	
Total Cash & Investments	25,000,000	-	-	-	25,000,000	-		25,000,000	30,133,969	

Quarterly Budget Review Statement
for the period 01/01/24 to 31/03/24

Gwydir Shire Council
Contracts Budget Review Statement

Budget review for the quarter ended 30 September 2023
Part A - Contracts Listing - contracts entered into during the quarter

Contractor	Contract Code	Contract detail & purpose	Contract Value to date	Start Date	Duration of Contract	Budgeted (Y/N)	Notes
Crawford Constructions	GWY_2024_T04	Demolition of Bingara Administration Building	\$350,000	1-Jul-23	2024 FY	Y	
Roger Moore PTY Ltd	GWY_1920_T01	Supply of Fuel	\$300,000	1-Jul-23	2024 FY	Y	
Arjo	GWY_2024_Q02	Naroo Bed Replacement Program	\$148,723	1-Jul-23	2024 FY	Y	
Roadwork Industries	VP376194	Bitumen Resurfacing Program	\$1,500,000	1-Jul-23	2024 FY	Y	
Engineering & Civil Contractors	VP345672	Footpath and Concreting Works	\$730,000	1-Jul-23	2024 FY	Y	
Irwin Fencing	VP348276	Guardrail and Terminal Upgrades	\$650,000	1-Jul-23	2024 FY	Y	
JR Richards		Waste collection and processing	\$450,000	1-Jul-23	2024 FY	Y	
AGL	LGP Contract	Small Sites Electricity	\$450,000	1-Jul-23	2025 FY	Y	
Shell Energy Retail Pty Ltd	LGP Contract	Large Site 100 Waymouth Street, Adelaide SA 5000	\$150,000	1-Jul-23	2026 FY	Y	
Shell Energy Retail Pty Ltd	LGP Contract	Street Lig 100 Waymouth Street, Adelaide SA 5000	\$77,000	1-Jul-23	2027 FY	Y	
Enviro One Services and Installations Pty Ltd	GWY_2023_T05	Bingara Pressure Sewer System Product Supply and Service	\$500,000	1-Jul-23	2028 FY	Y	

Gwydir Shire Council

Quarterly Budget Review Statement
for the period 01/01/24 to 31/03/24

Consultancy & Legal Expenses Budget Review Statement

Consultancy & Legal Expenses Overview

Expense	YTD Expenditure (Actual Dollars)	Budgeted (Y/N)
Consultancies	181,822	y
Legal Fees	8,832	y

Definition of a consultant:

A consultant is a person or organisation engaged under contract on a temporary basis to provide recommendations or high level specialist or professional advice to assist decision making by management. Generally it is the advisory nature of the work that differentiates a consultant from other contractors.

Comments

Expenditure included in the above YTD figure includes: Project Management and Governance consultants.

10 COUNCILLORS' REPORTS

The General Manager sought the concurrence of the meeting to the following alterations, which was given, to the Council's meeting schedule:

- The Committee Meetings to be held on 13th June 2024 are cancelled;
- The Committee Meetings to be held on 11th July 2024 are cancelled;
- The Council Meeting to be held on 25th July 2024 is cancelled;
- The Council Meeting to be held on 29th August 2024 is cancelled; and;
- A Council Meeting will be held on Wednesday 7th August 2024.

11 COMMITTEE OF THE WHOLE - CONFIDENTIAL ITEMS

COUNCIL RESOLUTION:

THAT the Council resolve into Confidential Session, Committee of the Whole and that in the public interest and in accordance with Section 10A (2) of the Local Government Act, 1993, the public and press be excluded from the meeting to consider Item(s) listed on the Agenda.

(Moved Cr Mulligan, Seconded Cr Smith)

CARRIED

For: Cr J Coulton, Cr Egan, Cr D Coulton, Cr Galvin, Cr Matthews, Cr Moore, Cr Mulligan and Cr Smith

Against: Nil

11.1 Adoption of the Recommendations of the Confidential Session

The meeting was re-opened to the public at 4.59 pm.

COUNCIL RESOLUTION:

THAT the recommendations of the Confidential Session, namely:

Fuel Report

Cr J Coulton voted against this recommendation from the Committee.

Cr Moore declared an interest and left the meeting during discussion on this item.

THAT Council awards part tender GWY_2024_T01 to Mitala Pty Ltd trading as North West Petroleum Pty Ltd for deliveries of fuel to Council's Bingara Depot.

FURTHER that Council awards part tender GWY_2024_T01 to Roger Moore Pty Ltd for fuel deliveries to the remaining Shire facilities.

FURTHER that a period of 6 months is provided for both successful tenderers to resolve the issues identified in H Civil's independent evaluation of its safety systems or its contract is forfeited.

Bingara Administration Building

THAT the draft responses to the request for further information from the Office of Local Government, in its correspondence dated 30th April 2024, are adopted and endorsed as the Council's responses.

Bingara and Warialda Libraries - Opening Hours

THAT the revised operating hours to be introduced are noted.

Property Matters

THAT the Council accepts the counteroffer to purchase 39 Cunningham Street Bingara at a price of \$230,000 plus the legal costs involved.

FURTHER that the land be classified as operational once the purchase is finalised by Council and that the Seal of Council be affixed to all the necessary documentation.

FURTHER that the General Manager is authorised to progress the subdivision and sale of lots created from Lot 328 DP 727843.

FURTHER that the Council accepts the offer of \$72,500 for Lot 20 in Moore Street Bingara.

Vacuum Excavator Purchase

THAT Council purchases the Vermeer VSK70-800 vacuum excavation truck as per Vermeer quotation at \$277,727.00 excluding GST, plus onroad costs.

Draft Audit Office Report

THAT the General Manager is delegated with the authority to approve the Shire's Asset Management Plan and Strategies prior to the Council's response to the draft report on 12th June 2024.

are adopted.

(Moved Cr Mulligan, Seconded Cr Galvin)

CARRIED

For: Cr J Coulton, Cr Egan, Cr D Coulton, Cr Galvin, Cr Matthews, Cr Moore, Cr Mulligan and Cr Smith

Against: Nil

12 CLOSURE

The meeting closed at 5.02 pm.